

Endmills

I1 to I141

I

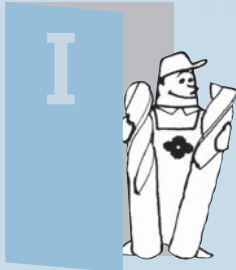

Selection Guides	I2
Cutting Edge Length List by Diameter	I6
Endmill Coating	I15
GSX MILL series	I16
SUMIDIA Coated SSDC series	I21
SSEH series	I22
Safe-Lock™ Compatible Endmill series	I23
GS MILL Hard series	I24
AURORA Coat Endmills	I25
Mold Finish Master series	I26

Square	General-Purpose	GSX MILL 2 Flutes	GSX 2000C-1.5D	I30		
		GSX MILL 2 Flutes	GSX 2000S-2D/2000C-2D	I32, I36		
		GSX MILL 2 Flutes	GSX 2000S-3D/2000C-3D	I38, I40		
		GSX MILL 2 Flutes	GSX 2000S-4D/2000C-4D	I42, I44		
		GSX MILL 3 Flutes	GSX 3000C-1.5D	I46		
		GSX MILL 3 Flutes	GSX 3000C-2D	I48		
		GSX MILL 4 Flutes	GSX 4000C-1.5D	I50		
		GSX MILL 4 Flutes	GSX 4000S-2D/4000C-2D	I52, I54		
		GSX MILL 4 Flutes	GSX 4000S-3D/4000C-3D	I56, I58		
		GSX MILL 4 Flutes	GSX 4000S-4D/4000C-4D	I60, I62		
Square	High Efficiency	Spiral SSM 2 Flutes	SSM 2000	I64		
		Spiral SSM 4 Flutes	SSM 4000	I68		
		GSX MILL Anti-vibration 4 Flutes	GSV 4000-2.5D	I70		
		GSX MILL Anti-vibration 4 Flutes	GSXVL 4000-2.5D	I72		
		UP MILL 4 Flutes	SSUP 4000ZX	I74		
		Long Neck UP MILL 4 Flutes	SSUPR 4000ZX	I75		
		Hardened Steel	Hardened Steel	GS MILL Hard 4/6/8 Flutes	GSH 4000SF/6000SF/8000SF	I76, I77, I78
				Hard HHM 4/6/8 Flutes	HHM 4000ZX/6000ZX/8000ZX	I79, I80, I81
				Hard LHHM 4/6/8 Flutes	LHHM 4000ZX/6000ZX/8000ZX	I82, I83, I84
				Hard EHHM 4/6/8 Flutes	EHHM 4000ZX/6000ZX/8000ZX	I85, I86, I87
Roughing	Roughing	GS MILL Roughing 4 Flutes	GSRE 4000SF	I88		
		Non-Ferrous Metals AURORA Coat 2/4 Flutes	ASM 2000DL/4000DL	I90, I91		
Non-Ferrous Metal	Non-Ferrous Metal	Non-Ferrous Metals 2 Flutes	ASM 2000	I92		
		Non-Ferrous Metals SUMIDIA 2/4 Flutes	DFE	I93		
		Non-Ferrous Metals SUMIDIA 1/2 Flutes	DAE	I95		
CFRP Graphite	CFRP Graphite	SUMIDIA Coated for CFRP 4 Flutes	SSDC 4000(RL)	I97		
Radius	Radius	GSX MILL 4 Flutes	GSX 4000-R-2D	I98		
		GSX MILL Anti-vibration 4 Flutes	GSV 4000-R-2.5D	I100		
		GSX MILL Anti-vibration 4 Flutes	GSXVL 4000-R-2.5D	I102		
		Exotic Alloy SSEH Anti-vibration 4 Flutes	SSEHVL 4000W-R/4000WS-R	I104, I106		
		Exotic Alloy SSEH 4 Flutes	SSEH 4000W-R/4000WS-R	I108, I110		
		UP MILL 4 Flutes	SSUP 4000ZX-R	I112		
		Long Neck UP MILL 4 Flutes	SSUPR 4000ZX-R	I114		
		GS MILL Hard 6/8 Flutes	GSH 6000SF-R/8000SF-R	I116, I117		
		Exotic Alloy SSEH Anti-vibration 4 Flutes	SSEHVL 4000-R	I118		
		Exotic Alloy SSEH 4 Flutes	SSEH 4000-R	I119		
		Mold Finish Master series 1 Flute	NPDRS	I120		
		Mold Finish Master series 2 Flutes	BNBR	I122		
		Ballnose	Ballnose	GSX MILL Ballnose 2 Flutes	GSXB 2000	I124
				GS MILL Hard Ballnose 2 Flutes	GSBH 2000SF	I126
Non-Ferrous Metals AURORA Coat Ballnose 2 Flutes	SNB 2000DL			I127		
Non-Ferrous Metals AURORA Coat Long Neck Ballnose 2 Flutes	SNB2			I128		
Mold Finish Master series 1 Flute	NPDBS/NPDB			I130, I131		
SUMIDIA Coated Ballnose 2 Flutes	SDCB			I132		
Mold Finish Master series 2 Flutes	BNBP/BNBC			I134, I136		
Multi-Purpose	Multi-Purpose	GSX MILL Slot 3 Flutes	GSXSLT 3000C-1.5D	I 138		
		UP MILL 3 Flutes	SSUP 3000ZX	I 140		

Stock Markings and Symbols

- mark: Standard stocked item
- mark: To be replaced with the new item featured on the same page
- ▲ mark: To be replaced by a new product, made to order, or discontinued (please confirm stock availability)
- * mark: Semi-standard stock (please confirm stock availability)
- mark: Stock or planned stock (please confirm stock availability)
- Blank: Made-to-order item
- mark: Not available

Endmills I Square Radius Ballnose Multi-Purpose General-Purpose High Efficiency Hardened Steel Roughing Non-Ferrous Metal CFRP Coated Uncoated

Square Endmill Selection Guides

● : Best (1st Recommendation)

◎ : Best, ○ : Good, Blank: Not recommended, x: Unsuitable

Applications / Features	Diameter DC (Min. to Max.) (mm)	Series Name / Series Code	Ref. Page	Appearance	Work Material																
					P				H		M	S	K	N							
					General Structure Rolled Steel	Carbon Steel	Alloy Steel	Pre-hardened Steel	30 to 45HRC Tempered Steel/Die Steel	45 to 55HRC	55 to 60HRC	60 up HRC	Hardened Steel	Stainless Steel	Titanium Alloy/Heat-Resistant Alloy	Cast Iron	Aluminum Alloy	Copper Alloy	Graphite	CFRP	
General-Purpose	ø0.5 to 25	GSXMILL 2 Flutes GSX 20000C	130,136, 140,144		●	●	●	●	●	●	○		●	○	●						
	ø0.5 to 25 (2D: ø0.3 to 25)	GSXMILL 2 Flutes GSX 20000S	132 to 134, 138, 142		○	◎	◎	◎	◎	◎	○		◎	○	○						
	ø1 to 12	GSXMILL 3 Flutes GSX 30000C	146,148		○	◎	◎	◎	◎	◎			◎	○	○						
	ø1 to 25	GSXMILL 4 Flutes GSX 40000C	150,154, 158,162		●	●	●	●	●	●	○		●	○	●						
	ø1 to 25	GSXMILL 4 Flutes GSX 40000S	152,156, 160		○	◎	◎	◎	◎	◎	○		◎	○	○						
	ø0.2 to 30	Solid Carbide Spiral 2 Flutes SSM 2000	164		○	◎										○	○				
	ø1.5 to 25	Solid Carbide Spiral 4 Flutes SSM 4000	168		○	◎										○	○				
High Efficiency	ø2 to 25	GSXMILL Anti-vibration 4 Flutes GSXVL 4000	172		●	●	●	●	●	●	○		●	○	○						
	ø2 to 25	GSV Anti-vibration 4 Flutes GSV 4000	170		◎	◎	◎	◎	◎	◎	○		◎	○	○						
	ø2 to 20	UPMILL SSUP 4000ZX	174		◎	◎	◎	◎	◎	◎	○		◎	○	○						
	ø3 to 20	UPMILL Long Neck SSUPR 4000ZX	175		◎	◎	◎	◎	◎	◎	○		◎	○	○						
Hardened Steel	④ ø1 to 2 ⑥ ø3 to 12 ⑧ ø16 to 20	GS MILL Hard GSH 4/6/8000SF	176 to 178		●	●	●	●	●	●	○										
	④ ø3 to 5 ⑥ ø6 to 12 ⑧ ø16 to 32	Hard HHM 4/6/8000ZX	179 to 181		○	○	○	◎	◎	◎	○										
	④ ø3 to 5 ⑥ ø6 to 12 ⑧ ø16 to 32	Long Hard LHHM 4/6/8000ZX	182 to 184		○	○	○	◎	◎	◎	○										
	④ ø3 to 5 ⑥ ø6 to 12 ⑧ ø16 to 32	Extra-Long Hard EHHM 4/6/8000ZX	185 to 187		○	○	○	◎	◎	◎	○										
Non-Ferrous Metal	ø6 to 20	GS MILL Roughing GSRE 4000SF	188		◎	◎	◎	◎	◎	◎			◎	○	◎						

④⑥⑧: No. of Flutes

Examples of Icons on Product Stock Pages

Coating:

No. of Flutes:

Shape:

Applications:



! Our square endmill cutting edge shapes have **concave ends**.

Therefore, they do not make flat bottoms in spot facing.

If a flat bottom is required, we recommend using the **Flat MULTIDRILL MDF type**.

Square Endmill Selection Guides

● : Best (1st Recommendation)

◎ : Best, ○ : Good, Blank: Not recommended, x: Unsuitable

Applications / Features	Diameter DC (Min. to Max.) (mm)	Series Name / Series Code	Ref. Page	Appearance	Work Material																	
					P				H			M	S	K	N							
					General Structure Rolled Steel	Carbon Steel	Alloy Steel	Pre-hardened Steel	30 to 46HRC Tempered Steel/Die Steel	45 to 56HRC	55 to 60HRC	60 up HRC	Hardened Steel	Stainless Steel	Titanium Alloy/Heat-Resistant Alloy	Cast Iron	Aluminum Alloy	Copper Alloy	Graphite	CFRP		
Aluminum and Non-Ferrous Metal	ø2 to 16	AURORA Coat 2 Flutes ASM 2000DL	190																			
	ø2 to 16	AURORA Coat 4 Flutes ASM 4000DL	191																	◎	◎	
	ø2 to 16	Solid Carbide Endmills for Non-ferrous Cutting ASM 2000	192																	◎	◎	
	①ø4 to 5 ②ø6 to 12	SUMIDIA Endmills DAE series DAE	195, 196		x	x	x	x	x	x	x	x	x	x	x	x	◎	◎	○			
	②ø4 to 10 ④ø9 to 13	SUMIDIA Endmills DFE series DFE	193, 194		x	x	x	x	x	x	x	x	x	x	x	◎	◎	○				
CFRP/ Graphite	ø6 to 12	SUMIDIA Coated SSDC SSDC 4000	197		x	x	x	x	x	x	x	x	x	x	x				○	●		
	ø6 to 12	SUMIDIA Coated SSDCRL SSDC 4000RL	197		x	x	x	x	x	x	x	x	x	x	x				○	●		
Multi-Purpose	ø1 to 12	GSX MILL Slot 3 Flutes GSXSLT 30000C	1138		○	●	●	●	●	●			●	○	○							
	ø2 to 16	UPMILL Slot SSUP 3000ZX	1140		◎	◎	◎	◎	◎	◎	○		◎	○	○							

①②④: No. of Flutes

Target Work Material (What to machine?)	Cutting Applications	Recommended Tool	Ref. Page
Steel, Cast Iron, Stainless Steel, Titanium Alloy	High-efficiency Machining Chatter Countermeasures	GSXVL GSV	172 170
	Medium Finishing to Finishing (Good Machining Accuracy)	GSX	130 to 163
	Medium Finishing (Medium Stock Removal)	GSH	176 to 178
	Roughing (Large Stock Removal)	GSXVL GSRE	172 188
Hardened Steel (45HRC up)	All Hardened Steels	GSH	176 to 178
Aluminum Alloy	All Aluminum Alloys	ASM	190 to 192
CFRP, Graphite	Roughing, Cut-off	SSDC SSDCRL	197

Endmills
I
Square
Radius
Ballnose
Multi-Purpose
General-Purpose
High Efficiency
Hardened Steel
Roughing
Non-Ferrous Metal
CFRP
Coated
Uncoated

Corner Radius Endmill Selection Guide

● : Best (1st Recommendation)

◎ : Best, ○ : Good, Blank: Not recommended, x: Unsuitable

Applications / Features	Diameter DC (Min. to Max.) (mm)	Series Name / Series Code	Ref. Page	Appearance	Work Material																		
					P				H		M	S	K	N									
					General Structure Rolled Steel	Carbon Steel	Alloy Steel	Pre-hardened Steel	30 to 45HRC Tempered Steel/Die Steel	45 to 55HRC	55 to 60HRC	60 up HRC	Hardened Steel	Stainless Steel	Titanium Alloy/Heat-Resistant Alloy	Cast Iron	Aluminum Alloy	Copper Alloy	Graphite	CFRP			
General Endmilling with Corner Radius	ø3 to 12	GSX MILL Radius GSX 40000-R	I98		◎	◎	◎	◎	◎	◎				◎	○	○							
High-efficiency Endmilling with Corner Radius	ø3 to 25	GSX MILL Anti-vibration Radius	I102		○	●	●	●	●	●	○			●	○	○							
	ø3 to 25	GSV Anti-vibration Radius GSV 4000-R	I100		○	◎	◎	◎	◎	◎	○			◎	○	○							
	ø3 to 20	UPMILL Radius SSUP 4000ZX-R	I112		◎	◎	◎	◎	◎	◎	○			◎	○	◎							
	ø3 to 20	UPMILL Long Neck Radius SSUPR 4000ZX-R	I114		◎	◎	◎	◎	◎					○		◎							
Hardened Steel Endmilling with Corner Radius	⑥ ø6 to 12 ③ ø16 to 20	GS MILL Hard Radius GSH 6/8000SF-R	I116 to I117			●	●	●	●	●	●	●											
Exotic Alloy	ø4.5 to 25 ④ ø12 to 25	SSEH Anti-vibration Radius SSEHVL 4000W(S)-R	I104, I106												●	●							
	ø4.5 to 25 ④ ø12 to 25	SSEH Radius SSEH 4000W(S)-R	I108, I110												◎	◎							
	ø4.5 to 16	SSEH Anti-vibration Radius SSEHVL 4000-R	I118												○	◎							
	ø4.5 to 16	SSEH Radius SSEH 4000-R	I119												○	◎							
High-precision Mold Profiling	ø0.2 to 2	Mold Finish Master SUMIBORON Radius Endmills BNBR	I122							○	○	◎	◎							x	x		
Cemented Carbide and Hard Brittle Material	ø0.2 to 2	Mold Finish Master SUMIDIA BINDERLESS Radius Endmills NPDRS	I120		Cemented Carbide				◎	Hard Brittle Material				○									







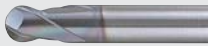

◎◎: No. of Flutes ④: SAFE-LOCK™ Applicable Products

Target Work Material (What to machine?)	Cutting Applications	Recommended Tool	Ref. Page
Steel, Cast Iron, Stainless Steel, Titanium Alloy	High-efficiency Machining Chatter Countermeasures	GSXVL GSV	I102 I100
	Medium Finishing to Finishing (Good Machining Accuracy)	GSX SSUP	I98 I112
	Roughing (Large Stock Removal)	GSXVL	I102
	Stainless Steel, Titanium Alloy	SSEH SSEHVL	I108,I110 I104,I106 I118,I119
Hardened Steel (45HRC up)	Hardened Steel Overall Endmilling with Corner Radius	GSH	I116,I117
	High-precision Mold Profiling	BNBR	I122
CFRP, Graphite	Roughing, Cut-off	SSDC SSDCRL	I97
Cemented Carbide, Hard Brittle Materials	Finishing	NPDRS	I120

Ballnose Endmill Selection Guide

● : Best (1st Recommendation)

◎ : Best, ○ : Good, Blank: Not recommended, x: Unsuitable

Applications / Features	Ballnose Radius (Min. to Max.) / Tolerance (mm)	Series Name / Series Code	Ref. Page	Appearance	Work Material																		
					P				H				M	S	K	N							
					General Structure Rolled Steel	Carbon Steel	Alloy Steel	Pre-hardened Steel	30 to 45HRC Tempered Steel/Die Steel	45 to 55HRC	55 to 60HRC	60 up HRC	Hardened Steel	Stainless Steel	Titanium Alloy/Heat-Resistant Alloy	Cast Iron	Aluminum Alloy	Copper Alloy	Graphite	CFRP			
General-Purpose	R0.2 to 10 ± 0.01	GSXMILL Ballnose GSXB 20000	I124		●	●	●	●	●	●	○			●	○	○							
Hardened Steel	R0.2 to 6 ±0.003 up to -0.007	GS MILL HARD Ballnose GSBH 20000SF	I126			◎	◎	◎	○	◎	●	●											
Aluminum and Non-Ferrous Metal	R1 to 8 ± 0.01	AURORA Coat Ballnose SNB 2000DL	I127															◎	◎				
Copper Electrodes	R0.05 to 2 ± 0.005	AURORA Coat Long Neck Ballnose Endmills SNB2	I128															◎	●				
	R0.1 to 0.5 ± 0.005	Mold Finish Master SUMIBORON Ballnose Endmills BNBC	I136																●				
High-precision Mold Profiling	R0.2 to 1 ± 0.005	Mold Finish Master SUMIBORON Ballnose Endmills BNBP	I134					○		○	◎	◎						x	x				
Cemented Carbide and Hard Brittle Material	R0.1 to 1	Mold Finish Master SUMIDIA BINDERLESS Ballnose Endmills NPDBS (For Standard Finishing)	I130		Cemented Carbide						◎											○	
	R0.1 to 1	Mold Finish Master SUMIDIA BINDERLESS Ballnose Endmills NPDB (For Precision Finishing)	I131		Cemented Carbide						◎												○
	R0.5 to 1	SUMIDIA Coat Ballnose Endmills SDCB	I132		Cemented Carbide						◎												○

Target Work Material (What to machine?)	Cutting Applications	Recommended Tool	Ref. Page
Steel, Cast Iron, Stainless Steel, Titanium Alloy	General Machining	GSXB	I124
Hardened Steel (45HRC up)	All Hardened Steels	GSBH	I126
	High-precision Mold Profiling	BNBP	I134
Aluminum Alloy Copper Alloy	All Aluminum Alloys, Copper	SNB	I127, I128
Copper Electrodes	Copper Alloy Overall	SNB2 BNBC	I128 I136
Cemented Carbide, Hard Brittle Materials	Roughing to Medium Finishing	SDCB	I132
	Finishing	NPDBS (Standard Finishing) NPDB (Precision Finishing)	I130 I131

Endmills

I

Square

Radius

Ballnose

Multi-Purpose

General-Purpose

High Efficiency

Hardened Steel

Roughing

Non-Ferrous Metal

CFRP

Coated

Uncoated

Cutting Edge Length List by Diameter

Diameter ϕ 0.2 to ϕ 1.6mm

Square

Dia. DC	Cutting Edge Length APMX	Cat. No.	Overall Length LF	Page
0.2	0.5	SSM 2002	40.0	164
0.3	0.6	GSX 20030S-2D	40.0	132
	1.0	SSM 2003	40.0	164
0.4	0.8	GSX 20040S-2D	40.0	132
	1.0	SSM 2004	40.0	164
0.5	1.0	GSX 20050C-1.5D	40.0	130
		GSX 20050C-2D	40.0	136
	1.3	GSX 20050S-2D	40.0	132
		GSX 20050C-3D	40.0	140
	1.5	GSX 20050S-3D	40.0	138
		SSM 2005	40.0	164
2.0	GSX 20050C-4D	40.0	144	
	GSX 20050S-4D	40.0	142	
0.6	1.3	GSX 20060S-2D	40.0	132
	1.5	SSM 2006	40.0	164
0.7	1.4	GSX 20070S-2D	40.0	132
	1.5	SSM 2007	40.0	164
0.8	1.6	GSX 20080S-2D	40.0	132
	2.0	SSM 2008	40.0	164
0.9	1.8	GSX 20090S-2D	40.0	132
	2.0	SSM 2009	40.0	164
1.0	1.5	GSX 20100C-1.5D	40.0	130
		GSX 30100C-1.5D	40.0	146
		GSX 40100C-1.5D	40.0	150
		GSXSALT 30100C-1.5D	40.0	1138
	2.0	GSX 20100C-2D	40.0	136
		GSX 40100C-2D	40.0	154
	2.5	GSX 20100S-2D	40.0	132
		GSX 30100C-2D	40.0	148
		GSX 40100S-2D	40.0	152
		GSX 40100S-2D-S3	38.0	152
	3.0	GSH 4010SF	50.0	176
		GSX 20100C-3D	40.0	140
GSX 20100S-3D		40.0	138	
GSX 40100C-3D		40.0	158	
4.0	GSX 40100S-3D	40.0	156	
	SSM 2010	40.0	164	
	GSX 20100C-4D	40.0	144	
	GSX 40100C-4D	40.0	162	
5.0	GSX 40100S-4D	40.0	160	
	GSX 20100S-4D	40.0	142	
1.1	2.5	GSX 20110S-2D	40.0	132
	3.0	SSM 2011	40.0	164
1.2	2.5	GSX 20120S-2D	40.0	132
	3.0	SSM 2012	40.0	164
1.3	2.6	GSX 20130S-2D	40.0	132
	3.0	SSM 2013	40.0	164
1.4	2.8	GSX 20140S-2D	40.0	132
	3.0	SSM 2014	40.0	164
1.5	2.3	GSX 20150C-1.5D	40.0	130
		GSX 30150C-1.5D	40.0	146
		GSX 40150C-1.5D	40.0	150
		GSXSALT 30150C-1.5D	40.0	1138
	3.0	GSX 20150C-2D	40.0	136
		GSX 40150C-2D	40.0	154
	3.8	GSX 20150S-2D	40.0	132
		GSX 20150S-2D-S3	38.0	132
		GSX 30150C-2D	40.0	148
		GSX 40150S-2D	40.0	152
	4.0	GSH 4015SF	50.0	176
		GSX 20150C-3D	40.0	140
GSX 20150S-3D		40.0	138	
GSX 40150C-3D		40.0	158	
4.5	GSX 40150S-3D	40.0	156	
	SSM 2015	40.0	164	
	SSM 4015	40.0	168	
	GSX 20150C-4D	40.0	144	
6.0	GSX 40150C-4D	40.0	162	
	GSX 40150S-4D	40.0	160	
	GSX 20150S-4D	40.0	142	
1.6	3.8	GSX 20160S-2D	40.0	132
	5.0	SSM 2016	40.0	164

Diameter ϕ 1.7 to ϕ 2.8mm

Square

Dia. DC	Cutting Edge Length APMX	Cat. No.	Overall Length LF	Page
1.7	3.8	GSX 20170S-2D	40.0	132
	5.0	SSM 2017	40.0	164
1.8	3.8	GSX 20180S-2D	40.0	132
	5.0	SSM 2018	40.0	164
1.9	3.8	GSX 20190S-2D	40.0	132
	5.0	SSM 2019	40.0	164
2.0	3.0	GSX 20200C-1.5D	40.0	130
		GSX 30200C-1.5D	40.0	146
		GSX 40200C-1.5D	40.0	150
		GSXSALT 30200C-1.5D	40.0	1138
	4.0	GSX 20200C-2D	40.0	136
		GSX 40200C-2D	40.0	154
	5.0	GSV 4020-2.5D	50.0	170
		GSX 20200S-2D	40.0	132
		GSX 20200S-2D-S3	38.0	132
		GSX 30200C-2D	40.0	148
		GSX 40200S-2D	40.0	152
		GSX 40200S-2D-S3	38.0	152
	6.0	GSXVL 4020-2.5D	50.0	172
		ASM 2020	40.0	192
		ASM 2020DL	40.0	190
		ASM 4020DL	40.0	191
		GSH 4020SF	50.0	176
		GSX 20200C-3D	40.0	140
		GSX 20200S-3D	40.0	138
		GSX 40200C-3D	40.0	158
		GSX 40200S-3D	40.0	156
		SSM 2020	40.0	164
	8.0	SSM 4020	40.0	168
		SSUP 3020ZX	50.0	1140
SSUP 4020ZX		50.0	174	
GSX 20200C-4D		40.0	144	
9.0	GSX 40200C-4D	40.0	162	
	GSX 40200S-4D	40.0	160	
2.1	6.0	GSX 20200S-4D	40.0	142
		GSX 20210S-2D	40.0	132
2.2	6.0	SSM 2021	40.0	164
		GSX 20220S-2D	40.0	132
2.3	6.0	SSM 2022	40.0	164
		GSX 20230S-2D	40.0	132
2.4	6.0	SSM 2023	40.0	164
		GSX 20240S-2D	40.0	132
2.5	6.0	SSM 2024	40.0	164
		GSX 20250C-1.5D	40.0	130
	3.8	GSX 30250C-1.5D	40.0	146
		GSX 40250C-1.5D	40.0	150
		GSXSALT 30250C-1.5D	40.0	1138
		GSX 20250C-2D	40.0	136
	5.0	GSX 40250C-2D	40.0	154
		GSX 20250S-2D	40.0	132
		GSX 30250C-2D	40.0	148
		GSX 40250S-2D	40.0	152
	7.5	GSX 20250C-3D	40.0	140
		GSX 20250S-3D	40.0	138
GSX 40250C-3D		40.0	158	
GSX 40250S-3D		40.0	156	
8.0	SSM 2025	40.0	164	
	SSM 4025	40.0	168	
	SSUP 3025ZX	50.0	1140	
	GSX 20250C-4D	50.0	144	
10.0	GSX 40250C-4D	50.0	162	
	GSX 40250S-4D	50.0	160	
	GSX 20250S-4D	50.0	142	
	GSX 20260S-2D	40.0	132	
2.6	7.0	GSX 20260S-3D	50.0	138
		SSM 2026	40.0	164
2.7	7.0	GSX 20270S-2D	40.0	132
		SSM 2027	40.0	164
		GSX 20270S-3D	50.0	138
2.8	7.0	GSX 20280S-2D	40.0	132
		SSM 2028	40.0	164
		GSX 20280S-3D	50.0	138

Cutting Edge Length List by Diameter

Diameter \varnothing 2.9 to \varnothing 4.0mm

Square

Dia. DC	Cutting Edge Length APMX	Cat. No.	Overall Length LF	Page
2.9	7.0	GSX 20290S-2D	40.0	132
	8.0	SSM 2029	40.0	164
	9.0	GSX 20290S-3D	50.0	138
3.0	4.5	GSX 20300C-1.5D	45.0	130
		GSX 30300C-1.5D	45.0	146
		GSX 40300C-1.5D	45.0	150
		GSXSLT 30300C-1.5D	45.0	1138
		SSUPR 4030ZX	60.0	175
		GSX 20300C-2D	45.0	136
	6.0	GSX 40300C-2D	45.0	154
		GSX 20300S-2D	45.0	132
	7.5	GSX 20300S-2D-S3	38.0	132
		GSX 30300C-2D	45.0	148
		GSX 40300S-2D	45.0	152
		GSX 40300S-2D-S3	38.0	152
8.0	GSH 6040SF	50.0	177	
	GSV 4030-2.5D	50.0	170	
	GSXVL 4030-2.5D	50.0	172	
	HHM 4030ZX	50.0	179	
	SSM 2030	45.0	164	
	SSM 4030	45.0	168	
	SSUP 3030ZX	50.0	1140	
	SSUP 4030ZX	50.0	174	
	9.0	GSX 20300C-3D	50.0	140
		GSX 20300S-3D	50.0	138
GSX 40300C-3D		50.0	158	
10.0	GSX 40300S-3D	50.0	156	
	ASM 2030	45.0	192	
	ASM 2030DL	45.0	190	
12.0	ASM 4030DL	45.0	191	
	GSX 20300C-4D	50.0	144	
	GSX 20300S-4D	50.0	142	
	GSX 40300C-4D	50.0	162	
	GSX 40300S-4D	50.0	160	
	LHHM 4030ZX	55.0	182	
	EHHM 4030ZX	60.0	185	
	20.0	GSX 20310S-2D	45.0	132
		SSM 2031	45.0	164
	3.1	7.5	GSX 20310S-2D	45.0
8.0		SSM 2031	45.0	164
3.2	7.5	GSX 20320S-2D	45.0	132
	8.0	SSM 2032	45.0	164
3.3	7.5	GSX 20330S-2D	45.0	132
	8.0	SSM 2033	45.0	164
3.4	7.5	GSX 20340S-2D	45.0	132
	8.0	SSM 2034	45.0	164
3.5	5.3	GSX 20350C-1.5D	45.0	130
		GSX 40350C-1.5D	45.0	150
	7.0	GSX 20350C-2D	45.0	136
		GSX 40350C-2D	45.0	154
	8.0	SSM 2035	45.0	164
		SSM 4035	45.0	168
	8.8	GSX 20350S-2D	45.0	132
		GSX 40350S-2D	45.0	152
	10.0	SSUP 3035ZX	50.0	1140
		GSX 20350C-3D	50.0	140
		GSX 40350C-3D	50.0	158
		GSX 40350S-3D	50.0	156
12.0		GSX 20350S-3D	50.0	138
		GSX 20350C-4D	50.0	144
14.0	GSX 20350S-4D	50.0	142	
	GSX 40350C-4D	50.0	162	
	GSX 40350S-4D	50.0	160	
	GSX 20360S-2D	45.0	132	
3.6	8.8	GSX 20360S-2D	45.0	132
	10.0	SSM 2036	45.0	164
3.7	8.8	GSX 20370S-2D	45.0	132
	10.0	SSM 2037	45.0	164
3.8	8.8	GSX 20380S-2D	45.0	132
3.8	10.0	SSM 2038	45.0	164
3.9	8.8	GSX 20390S-2D	45.0	132
	10.0	SSM 2039	45.0	164
4.0	6.0	GSX 20400C-1.5D	45.0	130
		GSX 30400C-1.5D	45.0	146
		GSX 40400C-1.5D	45.0	150

Diameter \varnothing 4.0 to \varnothing 5.0mm

Square

Dia. DC	Cutting Edge Length APMX	Cat. No.	Overall Length LF	Page
4.0	6.0	GSXSLT 30400C-1.5D	45.0	1138
		SSUPR 4040ZX	60.0	175
	8.0	GSX 20400C-2D	45.0	136
		GSX 40400C-2D	45.0	154
	10.0	GSV 4040-2.5D	50.0	170
		GSXVL 4040-2.5D	50.0	172
		HHM 4040ZX	50.0	179
		SSM 2040	45.0	164
		SSM 4040	45.0	168
		GSH 6040SF	50.0	177
	11.0	GSX 20400S-2D	45.0	132
		GSX 20400S-2D-S4	45.0	132
GSX 30400C-2D		45.0	148	
GSX 40400S-2D		45.0	152	
GSX 40400S-2D-S4		45.0	152	
SSUP 3040ZX		50.0	1140	
12.0	SSUP 4040ZX	50.0	174	
	ASM 2040	45.0	192	
	ASM 2040DL	45.0	190	
	ASM 4040DL	45.0	191	
	GSX 20400C-3D	50.0	140	
	GSX 20400S-3D	50.0	138	
15.0	GSX 40400C-3D	50.0	158	
	GSX 40400S-3D	50.0	156	
	LHHM 4040ZX	60.0	182	
	GSX 20400C-4D	50.0	144	
16.0	GSX 20400S-4D	50.0	142	
	GSX 40400C-4D	50.0	162	
	GSX 40400S-4D	50.0	160	
	EHHM 4040ZX	65.0	185	
4.1	10.0	SSM 2041	45.0	164
	11.0	GSX 20410S-2D	45.0	132
4.2	10.0	SSM 2042	45.0	164
	11.0	GSX 20420S-2D	45.0	132
4.3	10.0	SSM 2043	45.0	164
	11.0	GSX 20430S-2D	45.0	132
4.4	10.0	SSM 2044	45.0	164
	11.0	GSX 20440S-2D	45.0	133
4.5	6.8	GSX 20450C-1.5D	50.0	130
		GSX 40450C-1.5D	50.0	150
	9.0	GSX 20450C-2D	50.0	136
		GSX 40450C-2D	50.0	154
	10.0	SSM 2045	45.0	164
		SSM 4045	45.0	168
4.6	11.0	SSUP 3045ZX	50.0	1140
	11.3	GSX 20450S-2D	50.0	133
		GSX 40450S-2D	50.0	152
	14.0	GSX 20450C-3D	50.0	140
		GSX 40450C-3D	50.0	158
	15.0	GSX 20450S-3D	50.0	138
GSX 40450S-3D		50.0	156	
18.0	GSX 20450C-4D	60.0	144	
	GSX 20450S-4D	60.0	142	
	GSX 40450C-4D	60.0	162	
	GSX 40450S-4D	60.0	160	
4.7	11.3	GSX 20460S-2D	50.0	133
	12.0	SSM 2046	50.0	164
4.8	11.3	GSX 20470S-2D	50.0	133
	12.0	SSM 2047	50.0	165
4.9	11.3	GSX 20480S-2D	50.0	133
	12.0	SSM 2048	50.0	165
5.0	7.5	GSX 20490S-2D	50.0	133
		SSM 2049	50.0	165
	10.0	GSX 20500C-1.5D	50.0	130
		GSX 30500C-1.5D	50.0	146
		GSX 40500C-1.5D	50.0	150
		GSXSLT 30500C-1.5D	50.0	1138
12.0	SSUPR 4050ZX	60.0	175	
	GSX 20500C-2D	50.0	136	
12.0	GSX 40500C-2D	50.0	154	
	HHM 4050ZX	50.0	179	
		SSM 2050	50.0	165

Endmills

Square

Radius

Ballnose

Multi-Purpose

General-Purpose

High Efficiency

Hardened Steel

Roughing

Non-Ferrous Metal

CFRP

Coated

Uncoated

Cutting Edge Length List by Diameter

Diameter ϕ 5.0 to ϕ 6.0mm

Square

Dia. DC	Cutting Edge Length APMX	Cat. No.	Overall Length LF	Page
5.0	12.0	SSM 4050	50.0	168
		GSH 6050SF	50.0	177
		GSV 4050-2.5D	60.0	170
		GSX 20500S-2D	50.0	133
		GSX 30500C-2D	50.0	148
		GSX 40500S-2D	50.0	152
		GSXVL 4050-2.5D	60.0	172
		SSUP 3050ZX	60.0	1140
	13.0	SSUP 4050ZX	60.0	174
		ASM 2050	50.0	192
		ASM 2050DL	50.0	190
		ASM 4050DL	50.0	191
		GSX 20500C-3D	50.0	140
		GSX 20500S-3D	50.0	138
		GSX 40500C-3D	50.0	158
		GSX 40500S-3D	50.0	156
	18.0	LHHM 4050ZX	60.0	182
		GSX 20500C-4D	60.0	144
		GSX 20500S-4D	60.0	142
		GSX 40500C-4D	60.0	162
20.0	GSX 40500S-4D	60.0	160	
	EHHM 4050ZX	70.0	185	
	30.0	SSM 2051	50.0	165
		GSX 20510S-2D	50.0	133
5.1	12.0	SSM 2052	50.0	165
	13.0	GSX 20520S-2D	50.0	133
5.2	12.0	SSM 2053	50.0	165
	13.0	GSX 20530S-2D	50.0	133
5.3	12.0	SSM 2054	50.0	165
	13.0	GSX 20540S-2D	50.0	133
5.4	8.3	GSX 20550C-1.5D	50.0	130
		GSX 40550C-1.5D	50.0	150
	11.0	GSX 20550C-2D	50.0	136
		GSX 40550C-2D	50.0	154
	12.0	SSM 2055	50.0	165
		SSM 4055	50.0	168
	13.0	GSX 20550S-2D	50.0	133
		GSX 40550S-2D	50.0	152
		SSUP 3055ZX	60.0	1140
		GSX 20550C-3D	50.0	140
17.0	GSX 40550C-3D	50.0	158	
	GSX 20550S-3D	50.0	138	
	GSX 40550S-3D	50.0	156	
	GSX 20550C-4D	60.0	144	
22.0	GSX 20550S-4D	60.0	142	
	GSX 40550C-4D	60.0	162	
	GSX 40550S-4D	60.0	160	
	SSM 2056	50.0	165	
5.6	12.0	GSX 20560S-2D	50.0	133
	13.0	SSM 2057	50.0	165
5.7	12.0	SSM 2058	50.0	165
	13.0	GSX 20570S-2D	50.0	133
5.8	12.0	SSM 2059	50.0	165
	13.0	GSX 20580S-2D	50.0	133
5.9	12.0	SSM 2059	50.0	165
	13.0	GSX 20590S-2D	50.0	133
6.0	9.0	GSX 20600C-1.5D	50.0	130
		GSX 30600C-1.5D	50.0	146
		GSX 40600C-1.5D	50.0	150
		GSXSLT 30600C-1.5D	50.0	1138
		SSUPR 4060ZX	60.0	175
		GSX 20600C-2D	50.0	136
	12.0	GSX 40600C-2D	50.0	154
		HHM 6060ZX	50.0	180
		SSM 2060	50.0	165
		SSM 4060	50.0	168
		GSH 6060SF	50.0	177
		GSRE 4060SF	50.0	188
	13.0	GSX 20600S-2D	50.0	133
		GSX 30600C-2D	50.0	148
		GSX 40600S-2D	50.0	152
		SSUP 3060ZX	60.0	1140
		SSUP 4060ZX	60.0	174

Diameter ϕ 6.0 to ϕ 7.0mm

Square

Dia. DC	Cutting Edge Length APMX	Cat. No.	Overall Length LF	Page	
6.0	15.0	ASM 2060	50.0	192	
		ASM 2060DL	50.0	190	
		ASM 4060DL	50.0	191	
		GSV 4060-2.5D	60.0	170	
		GSXVL 4060-2.5D	60.0	172	
		GSX 20600C-3D	50.0	140	
	18.0	GSX 20600S-3D	50.0	138	
		GSX 40600C-3D	50.0	158	
		GSX 40600S-3D	50.0	156	
		LHHM 6060ZX	60.0	183	
		24.0	GSX 20600C-4D	60.0	144
			GSX 20600S-4D	60.0	142
30.0	GSX 40600C-4D	60.0	162		
	GSX 40600S-4D	60.0	160		
	EHHM 6060ZX	70.0	186		
	SSM 2061	50.0	165		
6.1	12.0	SSM 2061	50.0	165	
	13.0	GSX 20610S-2D	50.0	133	
6.2	12.0	SSM 2062	50.0	165	
	13.0	GSX 20620S-2D	50.0	133	
6.3	12.0	SSM 2063	50.0	165	
	13.0	GSX 20630S-2D	50.0	133	
6.4	12.0	SSM 2064	50.0	165	
	13.0	GSX 20640S-2D	50.0	133	
6.5	10.0	GSX 20650C-1.5D	60.0	130	
		GSX 40650C-1.5D	60.0	150	
	12.0	SSM 2065	50.0	165	
		SSM 4065	50.0	168	
	13.0	GSX 20650C-2D	60.0	136	
		GSX 20650S-2D	60.0	133	
		GSX 40650C-2D	60.0	154	
		GSX 40650S-2D	60.0	152	
	16.0	SSUP 3065ZX	70.0	1140	
		GSX 20650C-3D	70.0	140	
GSX 20650S-3D		70.0	138		
GSX 40650C-3D		70.0	158		
20.0	GSX 40650S-3D	70.0	156		
	GSX 20650C-4D	70.0	144		
	GSX 20650S-4D	70.0	142		
	GSX 40650C-4D	70.0	162		
26.0	GSX 40650S-4D	70.0	160		
	SSM 2066	55.0	165		
	6.6	13.2	GSX 20660S-2D	60.0	133
		15.0	SSM 2066	55.0	165
6.7	13.4	GSX 20670S-2D	60.0	133	
	15.0	SSM 2067	55.0	165	
6.8	13.6	GSX 20680S-2D	60.0	133	
	15.0	SSM 2068	55.0	165	
6.9	13.8	GSX 20690S-2D	60.0	133	
	15.0	SSM 2069	55.0	165	
7.0	10.5	SSUPR 4070ZX	80.0	175	
		GSX 20700C-1.5D	60.0	130	
		GSX 30700C-1.5D	60.0	146	
	11.0	GSX 40700C-1.5D	60.0	150	
		GSXSLT 30700C-1.5D	60.0	1138	
		GSX 20700C-2D	60.0	136	
	14.0	GSX 40700C-2D	60.0	154	
		SSM 2070	55.0	165	
		SSM 4070	55.0	168	
	15.0	GSRE 4070SF	60.0	188	
		GSX 20700S-2D	60.0	133	
		GSX 30700C-2D	60.0	148	
GSX 40700S-2D		60.0	152		
SSUP 3070ZX		70.0	1140		
SSUP 4070ZX		70.0	174		
18.0	GSV 4070-2.5D	70.0	170		
	GSXVL 4070-2.5D	70.0	172		
	21.0	GSX 20700C-3D	70.0	140	
		GSX 20700S-3D	70.0	138	
28.0	GSX 40700C-3D	70.0	158		
	GSX 40700S-3D	70.0	156		
	GSX 20700C-4D	80.0	144		
	GSX 20700S-4D	80.0	142		
SSUP 4070ZX	80.0	162			

Cutting Edge Length List by Diameter

Diameter $\varnothing 7.0$ to $\varnothing 8.3\text{mm}$

Square

Dia. DC	Cutting Edge Length APMX	Cat. No.	Overall Length LF	Page	
7.0	28.0	GSX 40700S-4D	80.0	160	
	15.0	SSM 2071	55.0	165	
7.1	16.0	GSX 20710S-2D	60.0	133	
	15.0	SSM 2072	55.0	165	
7.2	16.0	GSX 20720S-2D	60.0	133	
	15.0	SSM 2073	55.0	165	
7.3	16.0	GSX 20730S-2D	60.0	133	
	15.0	SSM 2074	55.0	165	
7.4	16.0	GSX 20740S-2D	60.0	133	
	12.0	GSX 20750C-1.5D	60.0	130	
7.5	12.0	GSX 40750C-1.5D	60.0	150	
		GSX 20750C-2D	60.0	136	
	15.0	GSX 40750C-2D	60.0	154	
		SSM 2075	55.0	165	
		SSM 4075	55.0	168	
	16.0	GSX 20750S-2D	60.0	133	
		GSX 40750S-2D	60.0	152	
	23.0	SSUP 3075ZX	70.0	1140	
		GSX 20750C-3D	70.0	140	
		GSX 20750S-3D	70.0	138	
		GSX 40750C-3D	70.0	158	
		GSX 40750S-3D	70.0	156	
		30.0	GSX 20750C-4D	80.0	144
			GSX 20750S-4D	80.0	142
			GSX 40750C-4D	80.0	162
	GSX 40750S-4D		80.0	160	
7.6	15.0	SSM 2076	55.0	165	
	16.0	GSX 20760S-2D	60.0	133	
7.7	15.0	SSM 2077	55.0	165	
	16.0	GSX 20770S-2D	60.0	133	
7.8	15.0	SSM 2078	55.0	165	
	16.0	GSX 20780S-2D	60.0	133	
7.9	15.0	SSM 2079	55.0	165	
	16.0	GSX 20790S-2D	60.0	133	
8.0	12.0	GSX 20800C-1.5D	60.0	130	
		GSX 30800C-1.5D	60.0	146	
		GSX 40800C-1.5D	60.0	150	
		GSXSLT 30800C-1.5D	60.0	1138	
	15.0	SSUPR 4080ZX	80.0	175	
		SSM 2080	55.0	165	
		SSM 4080	55.0	168	
	16.0	GSX 20800C-2D	60.0	136	
		GSX 40800C-2D	60.0	154	
	18.0	HHM 6080ZX	60.0	180	
		ASM 2080	60.0	192	
		ASM 2080DL	60.0	190	
	19.0	ASM 4080DL	60.0	191	
		GSH 6080SF	60.0	177	
		GSRE 4080SF	60.0	188	
		GSX 20800S-2D	60.0	133	
		GSX 30800C-2D	60.0	148	
		GSX 40800S-2D	60.0	152	
		SSUP 3080ZX	80.0	1140	
		SSUP 4080ZX	80.0	174	
	20.0	GSV 4080-2.5D	80.0	170	
		GSXVL 4080-2.5D	80.0	172	
	24.0	GSX 20800C-3D	70.0	140	
		GSX 20800S-3D	70.0	138	
		GSX 40800C-3D	70.0	158	
		GSX 40800S-3D	70.0	156	
	25.0	LHHM 6080ZX	75.0	183	
	32.0	GSX 20800C-4D	80.0	144	
		GSX 20800S-4D	80.0	142	
		GSX 40800C-4D	80.0	162	
		GSX 40800S-4D	80.0	160	
	40.0	EHHM 6080ZX	90.0	186	
8.1	15.0	SSM 2081	55.0	165	
	19.0	GSX 20810S-2D	60.0	133	
8.2	15.0	SSM 2082	55.0	165	
	19.0	GSX 20820S-2D	60.0	133	
8.3	15.0	SSM 2083	55.0	165	
	19.0	GSX 20830S-2D	60.0	133	

Diameter $\varnothing 8.4$ to $\varnothing 9.5\text{mm}$

Square

Dia. DC	Cutting Edge Length APMX	Cat. No.	Overall Length LF	Page
8.4	15.0	SSM 2084	55.0	165
	19.0	GSX 20840S-2D	60.0	133
8.5	13.0	GSX 20850C-1.5D	70.0	130
		GSX 40850C-1.5D	70.0	150
	15.0	SSM 2085	55.0	165
		SSM 4085	55.0	168
	17.0	GSX 20850C-2D	70.0	136
		GSX 40850C-2D	70.0	154
	19.0	GSX 20850S-2D	70.0	133
		GSX 40850S-2D	70.0	152
		SSUP 3085ZX	90.0	1140
	26.0	GSX 20850C-3D	75.0	140
		GSX 20850S-3D	75.0	138
		GSX 40850C-3D	75.0	158
GSX 40850S-3D		75.0	156	
34.0	GSX 20850C-4D	90.0	144	
	GSX 20850S-4D	90.0	142	
	GSX 40850C-4D	90.0	162	
	GSX 40850S-4D	90.0	160	
8.6	15.0	SSM 2086	55.0	165
	19.0	GSX 20860S-2D	70.0	133
8.7	15.0	SSM 2087	55.0	165
	19.0	GSX 20870S-2D	70.0	133
8.8	15.0	SSM 2088	55.0	165
	19.0	GSX 20880S-2D	70.0	133
8.9	15.0	SSM 2089	55.0	165
	19.0	GSX 20890S-2D	70.0	134
9.0	13.5	SSUPR 4090ZX	90.0	175
		GSX 20900C-1.5D	70.0	130
	14.0	GSX 30900C-1.5D	70.0	146
		GSX 40900C-1.5D	70.0	150
		GSXSLT 30900C-1.5D	70.0	1138
	15.0	SSM 2090	55.0	165
		SSM 4090	55.0	168
	18.0	GSX 20900C-2D	70.0	136
		GSX 40900C-2D	70.0	154
		GSRE 4090SF	70.0	188
	19.0	GSX 20900S-2D	70.0	134
		GSX 30900C-2D	70.0	148
		GSX 40900S-2D	70.0	152
		SSUP 3090ZX	90.0	1140
	23.0	SSUP 4090ZX	90.0	174
		GSV 4090-2.5D	90.0	170
27.0	GSXVL 4090-2.5D	90.0	172	
	GSX 20900C-3D	75.0	140	
36.0	GSX 20900S-3D	75.0	138	
	GSX 40900C-3D	75.0	158	
	GSX 40900S-3D	75.0	156	
	GSX 20900C-4D	90.0	144	
9.1	GSX 20900S-4D	90.0	142	
	GSX 40900C-4D	90.0	162	
	GSX 40900S-4D	90.0	160	
	9.2	15.0	SSM 2091	55.0
19.0		GSX 20910S-2D	70.0	134
9.3	15.0	SSM 2092	55.0	166
	19.0	GSX 20920S-2D	70.0	134
9.4	15.0	SSM 2093	55.0	166
	19.0	GSX 20930S-2D	70.0	134
9.5	15.0	SSM 2094	55.0	166
		GSX 20940S-2D	70.0	134
	19.0	GSX 20950C-1.5D	70.0	130
		GSX 40950C-1.5D	70.0	150
		SSM 2095	55.0	166
	20.0	SSM 4095	55.0	168
		GSX 20950C-2D	70.0	136
		GSX 40950C-2D	70.0	154
		SSUP 3095ZX	90.0	1140
	29.0	GSX 20950S-2D	70.0	134
		GSX 20950C-3D	75.0	140
	9.5	15.0	SSM 2095	55.0
19.0		GSX 20950S-3D	75.0	138

Endmills

1

Square

Radius

Ballnose

Multi-Purpose

General-Purpose

High Efficiency

Hardened Steel

Roughing

Non-Ferrous Metal

CFRP

Coated

Uncoated

Cutting Edge Length List by Diameter

Diameter ϕ 9.5 to ϕ 11.0mm

Square

Dia. DC	Cutting Edge Length APMX	Cat. No.	Overall Length LF	Page
9.5	29.0	GSX 40950S-3D	75.0	156
	38.0	GSX 20950C-4D	90.0	144
		GSX 20950S-4D	90.0	142
9.6	39.0	GSX 40950C-4D	90.0	162
		GSX 40950S-4D	90.0	160
9.7	18.0	SSM 2096	65.0	166
	20.0	GSX 20960S-2D	70.0	134
9.8	18.0	SSM 2097	65.0	166
	20.0	GSX 20970S-2D	70.0	134
9.9	18.0	SSM 2098	65.0	166
	20.0	GSX 20980S-2D	70.0	134
10.0	15.0	GSX 21000C-1.5D	70.0	130
		GSX 31000C-1.5D	70.0	146
		GSX 41000C-1.5D	70.0	150
		GSXSLT 31000C-1.5D	70.0	1138
		SSUPR 4100ZX	100.0	175
	18.0	SSM 2100	65.0	166
		SSM 4100	65.0	168
	20.0	GSX 21000C-2D	70.0	136
		GSX 41000C-2D	70.0	154
		HHM 6100ZX	71.0	180
22.0	ASM 2100	71.0	192	
	ASM 2100DL	71.0	190	
	ASM 4100DL	71.0	191	
	GSH 6100SF	70.0	177	
	GSRE 4100SF	70.0	188	
	GSX 21000S-2D	70.0	134	
	GSX 31000C-2D	70.0	148	
	GSX 41000S-2D	70.0	152	
25.0	SSUP 3100ZX	90.0	1140	
	SSUP 4100ZX	90.0	174	
30.0	GSV 4100-2.5D	90.0	170	
	GSXVL 4100-2.5D	90.0	172	
40.0	GSX 21000C-3D	90.0	140	
	GSX 21000S-3D	90.0	138	
	GSX 41000C-3D	90.0	158	
	GSX 41000S-3D	90.0	156	
50.0	LHHM 6100ZX	80.0	183	
	GSX 21000C-4D	90.0	144	
	GSX 21000S-4D	90.0	142	
10.5	16.0	GSX 21050C-1.5D	75.0	130
		GSX 41050C-1.5D	75.0	150
	18.0	SSM 2105	70.0	166
		GSX 21050C-2D	75.0	136
	21.0	GSX 41050C-2D	75.0	154
		GSX 21050S-2D	75.0	134
	22.0	GSX 41050S-2D	75.0	152
		GSX 21050C-3D	90.0	140
	32.0	GSX 21050S-3D	90.0	138
		GSX 41050C-3D	90.0	158
GSX 41050S-3D		90.0	156	
42.0	GSX 21050C-4D	100.0	144	
	GSX 21050S-4D	100.0	142	
	GSX 41050C-4D	100.0	162	
11.0	16.5	SSUPR 4110ZX	120.0	175
		GSX 21100C-1.5D	75.0	130
		GSX 41100C-1.5D	75.0	150
	17.0	SSM 2110	70.0	166
		SSM 4110	70.0	168
	22.0	GSRE 4110SF	75.0	188
		GSX 21100C-2D	75.0	136
		GSX 21100S-2D	75.0	134
		GSX 41100C-2D	75.0	154
		GSX 41100S-2D	75.0	152
SSUP 3110ZX		90.0	1140	
SSUP 4110ZX		90.0	174	

Diameter ϕ 11.0 to ϕ 13.0mm

Square

Dia. DC	Cutting Edge Length APMX	Cat. No.	Overall Length LF	Page
11.0	28.0	GSV 4110-2.5D	90.0	170
		GSXVL 4110-2.5D	90.0	172
	33.0	GSX 21100C-3D	90.0	140
		GSX 21100S-3D	90.0	138
		GSX 41100C-3D	90.0	158
		GSX 41100S-3D	90.0	156
	44.0	GSX 21100C-4D	100.0	144
		GSX 21100S-4D	100.0	142
		GSX 41100C-4D	100.0	162
	11.5	18.0	GSX 41100S-4D	100.0
GSX 21150C-1.5D			75.0	130
GSX 41150C-1.5D			75.0	150
23.0		SSM 2115	70.0	166
		GSX 21150C-2D	75.0	136
		GSX 21150S-2D	75.0	134
		GSX 41150C-2D	75.0	154
35.0		GSX 41150S-2D	75.0	152
		GSX 21150C-3D	90.0	140
		GSX 21150S-3D	90.0	138
46.0	GSX 41150C-3D	90.0	158	
	GSX 41150S-3D	90.0	156	
	GSX 21150C-4D	100.0	144	
	GSX 21150S-4D	100.0	142	
12.0	18.0	GSX 41150C-4D	100.0	162
		GSX 41150S-4D	100.0	160
		GSX 21200C-1.5D	75.0	130
	24.0	GSX 31200C-1.5D	75.0	146
		GSX 41200C-1.5D	75.0	150
		GSXSLT 31200C-1.5D	75.0	1138
		SSM 2120	70.0	166
	25.0	SSM 4120	70.0	168
		SSUPR 4120ZX	120.0	175
		GSX 21200C-2D	75.0	136
26.0	GSX 41200C-2D	75.0	154	
	HHM 6120ZX	75.0	180	
	ASM 2120	75.0	192	
	ASM 2120DL	75.0	190	
30.0	ASM 4120DL	75.0	191	
	GSH 6120SF	75.0	177	
	GSRE 4120SF	75.0	188	
	GSX 21200S-2D	75.0	134	
	GSX 31200C-2D	75.0	148	
	GSX 41200S-2D	75.0	152	
36.0	SSUP 3120ZX	90.0	1140	
	SSUP 4120ZX	90.0	174	
	GSV 4120-2.5D	90.0	170	
	GSXVL 4120-2.5D	90.0	172	
	LHHM 6120ZX	100.0	183	
	GSX 21200C-3D	90.0	140	
48.0	GSX 21200S-3D	90.0	138	
	GSX 41200C-3D	90.0	158	
	GSX 41200S-3D	90.0	156	
	GSX 21200C-4D	100.0	144	
50.0	GSX 21200S-4D	100.0	142	
	GSX 41200C-4D	100.0	162	
12.5	GSX 41200S-4D	100.0	160	
	EHHM 6120ZX	120.0	186	
13.0	19.5	SSM 2125	80.0	166
		SSUPR 4130ZX	130.0	175
	20.0	GSX 21250S-2D	75.0	134
		GSX 21300C-1.5D	90.0	130
		GSX 41300C-1.5D	90.0	150
	26.0	SSM 2130	80.0	166
		SSM 4130	80.0	168
		GSX 21300C-2D	90.0	136
		GSX 21300S-2D	90.0	134
		GSX 41300C-2D	90.0	154
GSX 41300S-2D		90.0	152	
SSUP 3130ZX		100.0	1140	
39.0	GSX 21300C-3D	100.0	140	
	GSX 21300S-3D	100.0	138	
		GSX 41300C-3D	100.0	158

Cutting Edge Length List by Diameter

Diameter ϕ 13.0 to ϕ 16.0mm

Square

Dia. DC	Cutting Edge Length APMX	Cat. No.	Overall Length LF	Page	
13.0	39.0	GSX 41300S-3D	100.0	156	
		GSX 21300C-4D	110.0	144	
	52.0	GSX 21300S-4D	110.0	142	
		GSX 41300C-4D	110.0	162	
		GSX 41300S-4D	110.0	160	
13.5	20.0	SSM 2135	80.0	166	
	27.0	GSX 41350S-2D	90.0	152	
14.0	20.0	SSM 2140	80.0	166	
		SSM 4140	80.0	168	
	21.0	GSX 21400C-1.5D	90.0	130	
		GSX 41400C-1.5D	90.0	150	
	26.0	GSRE 4140SF	90.0	188	
		SSUP 3140ZX	110.0	1140	
		SSUP 4140ZX	110.0	174	
	28.0	GSX 21400C-2D	90.0	136	
		GSX 21400S-2D	90.0	134	
		GSX 41400C-2D	90.0	154	
	32.0	GSX 41400S-2D	90.0	152	
		ASM 2140	90.0	192	
		GSV 4140-2.5D	110.0	170	
	35.0	GSXVL 4140-2.5D	110.0	172	
		GSX 21400C-3D	110.0	140	
		GSX 21400S-3D	110.0	138	
	42.0	GSX 41400C-3D	110.0	158	
		GSX 41400S-3D	110.0	156	
		GSX 21400C-4D	110.0	144	
	56.0	GSX 21400S-4D	110.0	142	
		GSX 41400C-4D	110.0	162	
		GSX 41400S-4D	110.0	160	
	14.5	25.0	SSM 2145	80.0	166
	15.0	23.0	GSX 21500C-1.5D	90.0	130
			GSX 41500C-1.5D	90.0	150
25.0		SSM 2150	80.0	166	
		SSM 4150	80.0	168	
26.0		SSUP 3150ZX	110.0	1140	
		SSUP 4150ZX	110.0	174	
30.0		GSX 21500C-2D	90.0	136	
		GSX 21500S-2D	90.0	134	
		GSX 41500C-2D	90.0	154	
32.0		GSX 41500S-2D	90.0	152	
		ASM 2150	90.0	192	
		GSV 4150-2.5D	110.0	170	
38.0		GSXVL 4150-2.5D	110.0	172	
		GSX 21500C-3D	110.0	140	
		GSX 21500S-3D	110.0	138	
45.0		GSX 41500C-3D	110.0	158	
		GSX 41500S-3D	110.0	156	
		GSX 21500C-4D	120.0	144	
60.0		GSX 21500S-4D	120.0	142	
		GSX 41500C-4D	120.0	162	
		GSX 41500S-4D	120.0	160	
15.5		35.0	SSM 2155	90.0	166
16.0		24.0	GSX 21600C-1.5D	90.0	130
			GSX 41600C-1.5D	90.0	150
			SSUPR 4160ZX	160.0	175
	32.0	ASM 2160	90.0	192	
		ASM 2160DL	90.0	190	
		ASM 4160DL	90.0	191	
		GSH 8160SF	90.0	178	
		GSRE 4160SF	90.0	188	
		GSX 21600C-2D	90.0	136	
		GSX 21600S-2D	90.0	134	
		GSX 41600C-2D	90.0	154	
		GSX 41600S-2D	90.0	152	
		HHM 8160ZX	90.0	181	
		SSUP 3160ZX	115.0	1140	
		SSUP 4160ZX	115.0	174	
	35.0	SSM 2160	90.0	166	
		SSM 4160	90.0	168	
	40.0	GSV 4160-2.5D	115.0	170	
		GSXVL 4160-2.5D	115.0	172	

Diameter ϕ 16.0 to ϕ 20.0mm

Square

Dia. DC	Cutting Edge Length APMX	Cat. No.	Overall Length LF	Page
16.0	48.0	GSX 21600C-3D	110.0	140
		GSX 21600S-3D	110.0	138
		GSX 41600C-3D	110.0	158
	50.0	GSX 41600S-3D	110.0	156
		LHHM 8160ZX	105.0	184
64.0	GSX 21600C-4D	120.0	144	
	GSX 21600S-4D	120.0	142	
	GSX 41600C-4D	120.0	162	
70.0	GSX 41600S-4D	120.0	160	
	EHHM 8160ZX	140.0	187	
16.5	35.0	SSM 2165	90.0	166
17.0	25.5	SSUPR 4170ZX	170.0	175
		GSX 21700C-1.5D	100.0	130
	26.0	GSX 41700C-1.5D	100.0	150
		GSX 21700C-2D	100.0	136
	34.0	GSX 41700C-2D	100.0	154
		GSX 21700S-2D	100.0	134
	35.0	GSX 41700S-2D	100.0	152
		SSM 2170	90.0	166
		GSX 21700C-3D	110.0	140
	51.0	GSX 21700S-3D	110.0	138
GSX 41700C-3D		110.0	158	
GSX 41700S-3D		110.0	156	
68.0	GSX 21700C-4D	130.0	144	
	GSX 21700S-4D	130.0	142	
	GSX 41700C-4D	130.0	162	
17.5	40.0	GSX 41700S-4D	130.0	160
		SSM 2175	105.0	166
18.0	27.0	GSX 21800C-1.5D	100.0	130
		GSX 41800C-1.5D	100.0	150
	32.0	GSRE 4180SF	100.0	188
		SSUP 4180ZX	120.0	174
	36.0	GSX 21800C-2D	100.0	136
		GSX 41800C-2D	100.0	154
		GSX 21800S-2D	100.0	134
	40.0	GSX 41800S-2D	100.0	152
		SSM 2180	105.0	166
		SSM 4180	105.0	168
	45.0	GSV 4180-2.5D	120.0	170
		GSXVL 4180-2.5D	120.0	172
	54.0	GSX 21800C-3D	120.0	140
		GSX 21800S-3D	120.0	138
		GSX 41800C-3D	120.0	158
72.0	GSX 41800S-3D	120.0	156	
	GSX 21800C-4D	130.0	144	
	GSX 21800S-4D	130.0	142	
18.5	40.0	GSX 41800C-4D	130.0	162
		GSX 41800S-4D	130.0	160
		SSM 2185	105.0	166
19.0	29.0	GSX 21900C-1.5D	100.0	130
		GSX 41900C-1.5D	100.0	150
	38.0	GSX 21900C-2D	100.0	136
		GSX 41900C-2D	100.0	154
		GSX 21900S-2D	100.0	134
	40.0	GSX 41900S-2D	100.0	152
		SSM 2190	105.0	166
		GSX 21900C-3D	120.0	140
	57.0	GSX 21900S-3D	120.0	138
		GSX 41900C-3D	120.0	158
GSX 41900S-3D		120.0	156	
76.0	GSX 21900C-4D	140.0	144	
	GSX 21900S-4D	140.0	142	
	GSX 41900C-4D	140.0	162	
19.5	40.0	GSX 41900S-4D	140.0	160
		SSM 2195	105.0	166
20.0	30.0	GSX 22000C-1.5D	100.0	130
		GSX 42000C-1.5D	100.0	150
	38.0	SSUPR 4200ZX	200.0	175
		GSH 8200SF	100.0	178
		GSRE 4200SF	100.0	188
SSUP 4200ZX	125.0	174		

Endmills
I
Square
Radius
Ballnose
Multi-Purpose
General-Purpose
High Efficiency
Hardened Steel
Roughing
Non-Ferrous Metal
CFRP
Coated
Uncoated

Cutting Edge Length List by Diameter

Diameter \varnothing 20.0 to \varnothing 32.0mm

Square

Dia. DC	Cutting Edge Length APMX	Cat. No.	Overall Length LF	Page
20.0	40.0	GSX 22000C-2D	100.0	I36
		GSX 22000S-2D	100.0	I34
		GSX 42000C-2D	100.0	I54
		GSX 42000S-2D	100.0	I52
		HHM 8200ZX	106.0	I81
		SSM 2200	105.0	I66
		SSM 4200	105.0	I68
	50.0	GSV 4200-2.5D	125.0	I70
		GSXVL 4200-2.5D	125.0	I72
	55.0	LHHM 8200ZX	120.0	I84
	60.0	GSX 22000C-3D	120.0	I40
		GSX 22000S-3D	120.0	I38
		GSX 42000C-3D	120.0	I58
		GSX 42000S-3D	120.0	I56
80.0	GSX 22000C-4D	140.0	I44	
	GSX 22000S-4D	140.0	I42	
	GSX 42000C-4D	140.0	I62	
	GSX 42000S-4D	140.0	I60	
85.0	EHHM 8200ZX	165.0	I87	
21.0	40.0	SSM 2210	105.0	I66
	42.0	GSX 22100S-2D	110.0	I34
22.0	40.0	SSM 2220	105.0	I66
	44.0	GSX 22200S-2D	110.0	I34
	66.0	GSX 42200S-3D	130.0	I56
23.0	45.0	SSM 2230	115.0	I66
	46.0	GSX 22300S-2D	120.0	I34
24.0	45.0	SSM 2240	115.0	I66
	48.0	GSX 22400S-2D	120.0	I34
	72.0	GSX 22400S-3D	130.0	I38
25.0	38.0	GSX 22500C-1.5D	120.0	I30
		GSX 42500C-1.5D	120.0	I50
	50.0	GSX 22500C-2D	120.0	I36
		GSX 22500S-2D	120.0	I34
		GSX 42500C-2D	120.0	I54
		GSX 42500S-2D	120.0	I52
		SSM 2250	120.0	I66
		SSM 4250	120.0	I68
	63.0	GSV 4250-2.5D	140.0	I70
	65.0	GSXVL 4250-2.5D	140.0	I72
	75.0	GSX 22500C-3D	130.0	I40
		GSX 22500S-3D	130.0	I38
		GSX 42500C-3D	130.0	I58
		GSX 42500S-3D	130.0	I56
EHHM 8250ZX		185.0	I87	
100.0	GSX 22500C-4D	160.0	I44	
	GSX 22500S-4D	160.0	I42	
	GSX 42500C-4D	160.0	I62	
	GSX 42500S-4D	160.0	I60	
30.0	55.0	SSM 2300	130.0	I66
	75.0	LHHM 8300ZX	160.0	I84
	110.0	EHHM 8300ZX	205.0	I87
32.0	64.0	HHM 8320ZX	130.0	I81
	85.0	LHHM 8320ZX	170.0	I84
	110.0	EHHM 8320ZX	205.0	I87

Diameter \varnothing 4.0 to \varnothing 8.0mm

Radius

Dia. DC	Cutting Edge Length APMX	Cat. No.	Overall Length LF	Page
4.0	6.0	SSUPR 4040ZX-R02	60.0	I114
		SSUPR 4040ZX-R05	60.0	I114
	10.0	GSV 4040-R02-2.5D	50.0	I100
		GSV 4040-R05-2.5D	50.0	I100
		GSV 4040-R10-2.5D	50.0	I100
		GSXVL 4040-R02-2.5D	50.0	I102
		GSXVL 4040-R05-2.5D	50.0	I102
		GSXVL 4040-R10-2.5D	50.0	I102
	11.0	GSX 40400-R02-2D	45.0	I98
		GSX 40400-R05-2D	45.0	I98
		GSX 40400-R10-2D	45.0	I98
		SSUP 4040ZX-R02	50.0	I112
	SSUP 4040ZX-R05	50.0	I112	
	SSUP 4040ZX-R10	50.0	I112	
4.5	12.0	SSEH 4045-R05	50.0	I119
		SSEH 4045W-R05	50.0	I108
		SSEHVL 4045-R05	50.0	I118
		SSEHVL 4045-R10	50.0	I118
		SSEHVL 4045W-R05	50.0	I104
		SSEHVL 4045W-R10	50.0	I104
5.0	7.5	SSUPR 4050ZX-R02	60.0	I114
		SSUPR 4050ZX-R05	60.0	I114
	13.0	GSV 4050-R02-2.5D	60.0	I100
		GSV 4050-R05-2.5D	60.0	I100
		GSV 4050-R10-2.5D	60.0	I100
		GSX 40500-R02-2D	50.0	I98
		GSX 40500-R05-2D	50.0	I98
		GSX 40500-R10-2D	50.0	I98
		GSXVL 4050-R02-2.5D	60.0	I102
		GSXVL 4050-R05-2.5D	60.0	I102
		GSXVL 4050-R10-2.5D	60.0	I102
		SSEH 4050-R05	60.0	I119
		SSEH 4050W-R05	60.0	I108
		SSEHVL 4050-R05	60.0	I118
SSEHVL 4050-R10	60.0	I118		
SSEHVL 4050W-R05	60.0	I104		
SSEHVL 4050W-R10	60.0	I104		
SSUP 4050ZX-R02	60.0	I112		
SSUP 4050ZX-R05	60.0	I112		
SSUP 4050ZX-R10	60.0	I112		
6.0	9.0	SSUPR 4060ZX-R03	60.0	I114
		SSUPR 4060ZX-R05	60.0	I114
	13.0	GSH 6060SF-R02	50.0	I116
		GSH 6060SF-R05	50.0	I116
		GSH 6060SF-R10	50.0	I116
		GSX 40600-R02-2D	50.0	I98
		GSX 40600-R05-2D	50.0	I98
		GSX 40600-R10-2D	50.0	I98
		GSX 40600-R15-2D	50.0	I98
		SSEH 4060-R10	60.0	I119
		SSEH 4060W-R10	60.0	I108
		SSEHVL 4060-R10	60.0	I118
		SSEHVL 4060W-R10	60.0	I104
		SSUP 4060ZX-R03	60.0	I112
SSUP 4060ZX-R05	60.0	I112		
SSUP 4060ZX-R10	60.0	I112		
SSUP 4060ZX-R15	60.0	I112		
15.0	GSV 4060-R03-2.5D	60.0	I100	
	GSV 4060-R05-2.5D	60.0	I100	
	GSV 4060-R10-2.5D	60.0	I100	
	GSV 4060-R15-2.5D	60.0	I100	
	GSXVL 4060-R03-2.5D	60.0	I102	
	GSXVL 4060-R05-2.5D	60.0	I102	
GSXVL 4060-R10-2.5D	60.0	I102		
GSXVL 4060-R15-2.5D	60.0	I102		
7.0	10.5	SSUPR 4070ZX-R03	80.0	I114
		SSUPR 4070ZX-R05	80.0	I114
8.0	12.0	SSUPR 4080ZX-R05	80.0	I114
		SSUPR 4080ZX-R10	80.0	I114

Diameter \varnothing 3.0mm

Radius

Dia. DC	Cutting Edge Length APMX	Cat. No.	Overall Length LF	Page
3.0	4.5	SSUPR 4030ZX-R02	60.0	I114
		SSUPR 4030ZX-R05	60.0	I114
	8.0	GSV 4030-R02-2.5D	50.0	I100
		GSV 4030-R05-2.5D	50.0	I100
		GSX 40300-R02-2D	45.0	I98
		GSX 40300-R05-2D	45.0	I98
		GSXVL 4030-R02-2.5D	50.0	I102
		GSXVL 4030-R05-2.5D	50.0	I102
		SSUP 4030ZX-R02	50.0	I112
		SSUP 4030ZX-R05	50.0	I112

Endmills

I

Square

Radius

Ballnose

Multi-Purpose

General-Purpose

High Efficiency

Hardened Steel

Roughing

Non-Ferrous Metal

CFRP

Coated

Uncoated

Cutting Edge Length List by Diameter

Diameter: ø8.0 to 12.0mm

Radius

Dia. DC	Cutting Edge Length APMX	Cat. No.	Overall Length LF	Page	
8.0	19.0	GSH 6080SF-R02	60.0	I116	
		GSH 6080SF-R05	60.0	I116	
		GSH 6080SF-R10	60.0	I116	
		GSX 40800-R02-2D	60.0	I98	
		GSX 40800-R05-2D	60.0	I98	
		GSX 40800-R10-2D	60.0	I98	
		GSX 40800-R15-2D	60.0	I98	
		SSEH 4080-R10	80.0	I119	
		SSEH 4080W-R10	80.0	I108	
		SSEHVL 4080-R10	80.0	I118	
		SSEHVL 4080W-R10	80.0	I104	
		SSUP 4080ZX-R03	80.0	I112	
		SSUP 4080ZX-R05	80.0	I112	
		SSUP 4080ZX-R10	80.0	I112	
		SSUP 4080ZX-R15	80.0	I112	
		SSUP 4080ZX-R20	80.0	I112	
	20.0	GSV 4080-R03-2.5D	80.0	I100	
		GSV 4080-R05-2.5D	80.0	I100	
		GSV 4080-R10-2.5D	80.0	I100	
		GSV 4080-R15-2.5D	80.0	I100	
		GSV 4080-R20-2.5D	80.0	I100	
		GSXVL 4080-R03-2.5D	80.0	I102	
		GSXVL 4080-R05-2.5D	80.0	I102	
		GSXVL 4080-R10-2.5D	80.0	I102	
	9.0	13.5	SSUPR 4090ZX-R05	90.0	I114
			SSUPR 4090ZX-R10	90.0	I114
	10.0	15.0	SSUPR 4100ZX-R05	100.0	I114
			SSUPR 4100ZX-R10	100.0	I114
SSUPR 4100ZX-R15			100.0	I114	
GSH 6100SF-R05			70.0	I116	
GSH 6100SF-R10		70.0	I116		
GSH 6100SF-R15		70.0	I116		
GSH 6100SF-R20		70.0	I116		
GSX 41000-R02-2D		70.0	I98		
GSX 41000-R05-2D		70.0	I98		
GSX 41000-R10-2D		70.0	I98		
GSX 41000-R15-2D		70.0	I98		
GSX 41000-R20-2D		70.0	I98		
SSEH 4100-R10		90.0	I119		
SSEH 4100-R30		90.0	I119		
SSEH 4100W-R10		90.0	I108		
SSEH 4100W-R30		90.0	I108		
SSEHVL 4100-R10		90.0	I118		
SSEHVL 4100-R30		90.0	I118		
SSEHVL 4100W-R10		90.0	I104		
SSEHVL 4100W-R30		90.0	I104		
SSUP 4100ZX-R03		90.0	I112		
SSUP 4100ZX-R05		90.0	I112		
SSUP 4100ZX-R10		90.0	I112		
SSUP 4100ZX-R15		90.0	I112		
SSUP 4100ZX-R20		90.0	I112		
25.0		GSV 4100-R03-2.5D	90.0	I100	
		GSV 4100-R05-2.5D	90.0	I100	
		GSV 4100-R10-2.5D	90.0	I100	
		GSV 4100-R15-2.5D	90.0	I100	
		GSV 4100-R20-2.5D	90.0	I100	
		GSXVL 4100-R03-2.5D	90.0	I102	
		GSXVL 4100-R05-2.5D	90.0	I102	
		GSXVL 4100-R10-2.5D	90.0	I102	
11.0		16.5	SSUPR 4110ZX-R05	120.0	I114
			SSUPR 4110ZX-R10	120.0	I114
12.0		18.0	SSUPR 4120ZX-R05	120.0	I114
			SSUPR 4120ZX-R10	120.0	I114
			SSUPR 4120ZX-R15	120.0	I114
		26.0	GSH 6120SF-R05	75.0	I116
			GSH 6120SF-R10	75.0	I116
	GSH 6120SF-R15		75.0	I116	

Diameter ø12.0 to ø20.0mm

Radius

Dia. DC	Cutting Edge Length APMX	Cat. No.	Overall Length LF	Page
12.0	26.0	GSH 6120SF-R20	75.0	I116
		GSX 41200-R02-2D	75.0	I98
		GSX 41200-R05-2D	75.0	I98
		GSX 41200-R10-2D	75.0	I98
		GSX 41200-R15-2D	75.0	I98
		GSX 41200-R20-2D	75.0	I98
		SSEH 4120-R10	90.0	I119
		SSEH 4120-R30	90.0	I119
		SSEH 4120W-R10	90.0	I108
		SSEH 4120W-R30	90.0	I108
		SSEH 4120WS-R10	90.0	I110
		SSEH 4120WS-R30	90.0	I110
		SSEHVL 4120-R10	90.0	I118
		SSEHVL 4120-R30	90.0	I118
		SSEHVL 4120W-R10	90.0	I104
		SSEHVL 4120W-R30	90.0	I104
	SSEHVL 4120WS-R10	90.0	I106	
	SSEHVL 4120WS-R30	90.0	I106	
	SSUP 4120ZX-R05	90.0	I112	
	SSUP 4120ZX-R10	90.0	I112	
	SSUP 4120ZX-R15	90.0	I112	
	SSUP 4120ZX-R20	90.0	I112	
	SSUP 4120ZX-R30	90.0	I112	
	30.0	GSV 4120-R05-2.5D	90.0	I100
		GSV 4120-R10-2.5D	90.0	I100
		GSV 4120-R15-2.5D	90.0	I100
		GSV 4120-R20-2.5D	90.0	I100
		GSV 4120-R30-2.5D	90.0	I100
		GSXVL 4120-R05-2.5D	90.0	I102
		GSXVL 4120-R10-2.5D	90.0	I102
		GSXVL 4120-R15-2.5D	90.0	I102
	13.0	19.5	SSUPR 4130ZX-R05	130.0
SSUPR 4130ZX-R10			130.0	I114
SSUPR 4130ZX-R15			130.0	I114
24.0		SSUPR 4160ZX-R10	160.0	I114
	SSUPR 4160ZX-R15	160.0	I114	
16.0	32.0	SSUPR 4160ZX-R20	160.0	I114
		GSH 8160SF-R10	90.0	I117
		GSH 8160SF-R15	90.0	I117
		GSH 8160SF-R20	90.0	I117
	SSEH 4160-R10	115.0	I119	
	SSEH 4160-R30	115.0	I119	
	SSEH 4160W-R10	115.0	I108	
	SSEH 4160W-R30	115.0	I108	
	SSEH 4160WS-R10	115.0	I110	
	SSEH 4160WS-R30	115.0	I110	
	SSEHVL 4160-R10	115.0	I118	
	SSEHVL 4160-R30	115.0	I118	
	SSEHVL 4160W-R10	115.0	I104	
	SSEHVL 4160W-R30	115.0	I104	
	SSEHVL 4160WS-R10	115.0	I106	
	SSEHVL 4160WS-R30	115.0	I106	
	SSUP 4160ZX-R10	115.0	I112	
	SSUP 4160ZX-R15	115.0	I112	
	SSUP 4160ZX-R20	115.0	I112	
	SSUP 4160ZX-R30	115.0	I112	
17.0	25.5	GSV 4160-R10-2.5D	115.0	I100
		GSV 4160-R15-2.5D	115.0	I100
		GSV 4160-R20-2.5D	115.0	I100
		GSV 4160-R30-2.5D	115.0	I100
		GSXVL 4160-R10-2.5D	115.0	I102
		GSXVL 4160-R15-2.5D	115.0	I102
		GSXVL 4160-R20-2.5D	115.0	I102
		GSXVL 4160-R30-2.5D	115.0	I102
20.0	30.0	SSUPR 4200ZX-R10	200.0	I114
		SSUPR 4200ZX-R15	200.0	I114
		SSUPR 4200ZX-R20	200.0	I114

Endmills

1

Square

Radius

Ballnose

Multi-Purpose

General-Purpose

High Efficiency

Hardened Steel

Roughing

Non-Ferrous Metal

CFRP

Coated

Uncoated

Cutting Edge Length List by Diameter

Diameter \varnothing 20.0 to \varnothing 25.0mm

Radius

Dia. DC	Cutting Edge Length APMX	Cat. No.	Overall Length LF	Page	
20.0	38.0	GSH 8200SF-R10	100.0	I117	
		GSH 8200SF-R15	100.0	I117	
		GSH 8200SF-R20	100.0	I117	
		SSUP 4200ZX-R10	125.0	I112	
		SSUP 4200ZX-R15	125.0	I112	
		SSUP 4200ZX-R20	125.0	I112	
	40.0	38.0	SSUP 4200ZX-R30	125.0	I112
			SSEH 4200W-R10	125.0	I108
		SSEH 4200W-R30	125.0	I108	
		SSEH 4200WS-R10	125.0	I110	
		SSEH 4200WS-R30	125.0	I110	
		SSEHVL 4200W-R10	125.0	I104	
		SSEHVL 4200W-R30	125.0	I104	
		SSEHVL 4200WS-R10	125.0	I106	
		SSEHVL 4200WS-R30	125.0	I106	
		50.0	38.0	GSV 4200-R10-2.5D	125.0
	GSV 4200-R15-2.5D			125.0	I100
	40.0		GSV 4200-R20-2.5D	125.0	I100
			GSV 4200-R30-2.5D	125.0	I100
	50.0		GSXVL 4200-R10-2.5D	125.0	I102
GSXVL 4200-R15-2.5D			125.0	I102	
GSXVL 4200-R20-2.5D			125.0	I102	
GSXVL 4200-R30-2.5D			125.0	I102	
25.0	50.0	SSEH 4250W-R10	140.0	I108	
		SSEH 4250W-R30	140.0	I108	
		SSEH 4250WS-R10	140.0	I110	
		SSEH 4250WS-R30	140.0	I110	
		SSEHVL 4250W-R10	140.0	I104	
		SSEHVL 4250W-R30	140.0	I104	
	63.0	50.0	SSEHVL 4250WS-R10	140.0	I106
			SSEHVL 4250WS-R30	140.0	I106
		63.0	GSV 4250-R10-2.5D	140.0	I100
			GSV 4250-R15-2.5D	140.0	I100
			GSV 4250-R20-2.5D	140.0	I100
			GSV 4250-R30-2.5D	140.0	I100
			GSXVL 4250-R10-2.5D	140.0	I102
			GSXVL 4250-R15-2.5D	140.0	I102
		63.0	GSXVL 4250-R20-2.5D	140.0	I102
			GSXVL 4250-R30-2.5D	140.0	I102

Diameter \varnothing 1.0 to \varnothing 20.0mm

Ballnose

Dia. DC	Cutting Edge Length APMX	Cat. No.	Overall Length LF	Page		
1.0	1.5	SNB2 0050 0404DL	45.0	I128		
		SNB2 0050 0604DL	45.0	I128		
		SNB2 0050 0804DL	50.0	I128		
1.5	1.5	SNB2 0050 1004DL	50.0	I128		
		GSBH 20075SF	50.0	I126		
	2.3	SNB2 0075 0304DL	45.0	I128		
		SNB2 0075 0604DL	45.0	I128		
		SNB2 0075 1004DL	50.0	I128		
		GSXB 20075	50.0	I124		
2.0	2.0	GSBH 20100SF	60.0	I126		
		GSXB 20100	60.0	I124		
	3.0	SNB 2020DL	60.0	I127		
		SNB2 0100 0304DL	50.0	I128		
		SNB2 0100 0604DL	50.0	I128		
		SNB2 0100 1004DL	50.0	I128		
		SNB2 0100 1504DL	60.0	I128		
		SNB2 0100 2004DL	60.0	I128		
		2.5	2.5	GSBH 20125SF	60.0	I126
			4.0	GSXB 20125	60.0	I124
3.0	3.0	GSBH 20150SF	60.0	I126		
		GSXB 20150	60.0	I124		
	4.5	SNB 2030DL	80.0	I127		
4.0	4.0	GSBH 20200SF	70.0	I126		
		GSXB 20200	70.0	I124		
	6.0	SNB 2040DL	80.0	I127		
		SNB2 0200 1606DL	80.0	I128		
		SNB2 0200 2006DL	80.0	I128		
		SNB2 0200 3006DL	80.0	I128		
5.0	5.0	GSBH 20250SF	80.0	I126		
	7.5	GSXB 20250	80.0	I124		
		SNB 2050DL	90.0	I127		
6.0	6.0	GSBH 20300SF	80.0	I126		
		GSXB 20300	80.0	I124		
	9.0	SNB 2060DL	100.0	I127		
7.0	11.0	GSXB 20350	90.0	I124		
		GSBH 20400SF	90.0	I126		
8.0	8.0	GSXB 20400	90.0	I124		
		SNB 2080DL	100.0	I127		
	12.0	GSBH 20500SF	100.0	I126		
10.0	10.0	GSXB 20500	100.0	I124		
		SNB 2100DL	120.0	I127		
	15.0	GSBH 20600SF	110.0	I126		
12.0	12.0	GSXB 20600	110.0	I124		
		SNB 2120DL	120.0	I127		
	18.0	GSXB 20700	110.0	I124		
14.0	21.0	GSXB 20800	140.0	I124		
		SNB 2160DL	160.0	I127		
16.0	24.0	GSXB 20900	140.0	I124		
		GSXB 21000	160.0	I124		
18.0	27.0	GSXB 20900	140.0	I124		
		GSXB 21000	160.0	I124		
20.0	30.0	GSXB 20900	140.0	I124		
		GSXB 21000	160.0	I124		

Diameter \varnothing 0.1 to \varnothing 1.0mm

Ballnose

0.1	0.1	SNB2 0005 0034DL	45.0	I128
		SNB2 0005 0064DL	45.0	I128
0.2	0.2	SNB2 0010 0054DL	45.0	I128
		SNB2 0010 0104DL	45.0	I128
		SNB2 0010 0204DL	45.0	I128
0.3	0.3	SNB2 0015 0054DL	45.0	I128
		SNB2 0015 0104DL	45.0	I128
		SNB2 0015 0204DL	45.0	I128
		SNB2 0015 0304DL	45.0	I128
0.4	0.4	GSBH 20020SF	50.0	I126
		SNB2 0020 0104DL	45.0	I128
		SNB2 0020 0204DL	45.0	I128
		SNB2 0020 0304DL	45.0	I128
		SNB2 0020 0404DL	45.0	I128
		GSXB 20020	50.0	I124
0.5	0.45	SNB2 0025 0104DL	45.0	I128
		SNB2 0025 0204DL	45.0	I128
		SNB2 0025 0304DL	45.0	I128
		SNB2 0025 0404DL	45.0	I128
0.6	0.6	GSBH 20030SF	50.0	I126
		SNB2 0030 0204DL	45.0	I128
		SNB2 0030 0304DL	45.0	I128
		SNB2 0030 0404DL	45.0	I128
		SNB2 0030 0504DL	45.0	I128
		SNB2 0030 0604DL	45.0	I128
1.0	1.0	GSXB 20030	50.0	I124
		GSBH 20050SF	50.0	I126
		GSXB 20050	50.0	I124
1.0	1.5	GSXB 20050	50.0	I124
		SNB2 0050 0304DL	45.0	I128

Endmill Coating

■ Endmill Coating

Coating Name	GSX Coat	GS Hard Coat	ZX Coat	AURORA Coat	SUMIDIA Coat
Coating type	TiAlCrN	TiAlCrSiCN	TiAlN	DLC	Diamond
Wear Resistance	◎	◎	○	○	◎
Adhesion Resistance	◎	◎	○	◎	△
Thermal Resistance	◎	◎	○	△	○
Coating Thickness	up to 2µm	up to 2µm	up to 2µm	up to 0.5µm	up to 15µm
Feature	Excellent thermal resistance and adhesion resistance	Excellent hardness, thermal resistance and adhesion resistance	General-purpose	Low coefficient of friction and excellent adhesion resistance	Excellent hardness and wear resistance
Main Application	For general steel and stainless steel milling	For general steel and high-hardness steel milling	For general steel and cast iron milling	For aluminum alloy and copper alloy milling	For CFRP milling
Main Applicable Products	GSX/GSXB/GSXVL series	GSH/GSBH/SSEH/SSEHVL series	UPMILL/HHM series	ASM/SNB/SNB2 series	SSDC series

● GSX Coat



- Micro-grain carbide substrate provides high transverse rupture strength and excellent thermal shock resistance, improving reliability in wet cutting applications.
- Adopts GSX Coat for better wear resistance and thermal resistance, improving reliability and tool life when machining a wide range of work materials.

[Coating Structure]

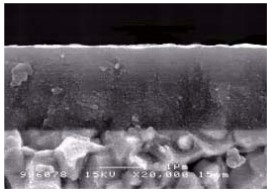

TiAlCrN-based Oxidation-Resistant Layer
TiAlN-based Wear-Resistant Layer
Ultra-Fine Grain Carbide Substrate

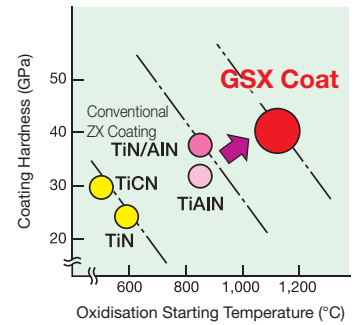
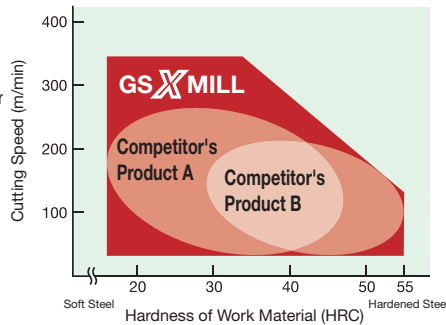

● GS Hard Coat



[Coating Surface Comparison]

GS Hard Coat

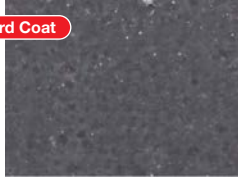

Conventional Coating

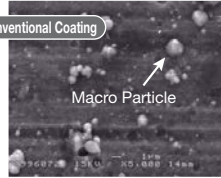

[Oxidation Resistance Evaluation] (Scratches from calotest performed after one-hour exposure to air at 1,100°C)

GS Hard Coat

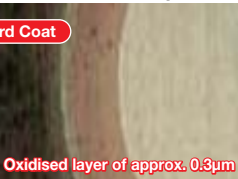

Oxidised layer of approx. 0.3µm

Conventional Coating

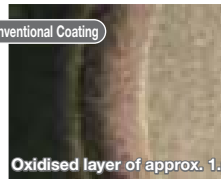

Oxidised layer of approx. 1.0µm

● ZX Coat



- Hardness almost equivalent to that of CBN
- Improvement in wear resistance, oxidation resistance and peel-off resistance
- Approx. 6 times longer tool life compared with uncoated products

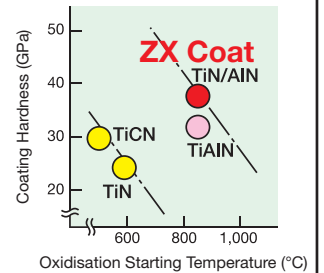
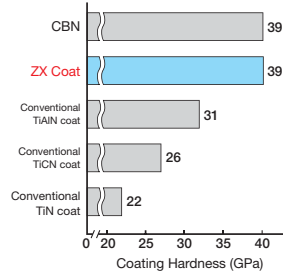

● AURORA Coat



- Very smooth AURORA COAT results in low adhesion as well as good surface finish
- Low cutting force enables high feed machining and milling of low rigidity workpieces
- Perfect for machining non-ferrous metal/copper electrodes



AURORA Coat

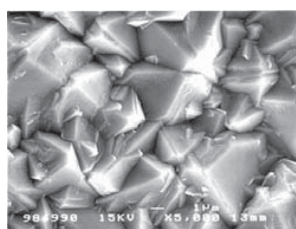

Competitor's Diamond Coating

● SUMIDIA Coat



- Our original polycrystalline diamond coating technology achieves over 10 times higher wear resistance than uncoated carbide
- Realizes a micro-grain diamond film that provides the required combination of high strength and high wear resistance on smooth surfaces for CFRP milling

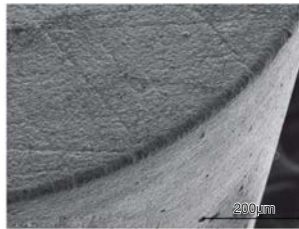

Endmills

I

Square

Radius

Ballnose

Multi-Purpose

General-Purpose

High Efficiency

Hardened Steel

Roughing

Non-Ferrous Metal

CFRP

Coated

Uncoated

GSX MILL series

Endmills

I

Square

Radius

Ballnose

Multi-Purpose

General-Purpose

High Efficiency

Hardened Steel

Roughing

Non-Ferrous Metal

CFRP

Coated

Uncoated



■ Features and Applications

- A wide selection with 3 types of cutting flute configurations and 4 cutting lengths to cover a wide range of applications
- Micro-grained carbide substrate provides high transverse rupture strength and excellent thermal shock resistance, improving reliability in wet cutting applications
- GSX Coat has increased wear resistance and thermal resistance for improved reliability and longer tool life
- Large rake angle and unique flute design improve sharpness and chip evacuation
- Utilizing a gash land improves cutting edge corner strength

● Wear resistance

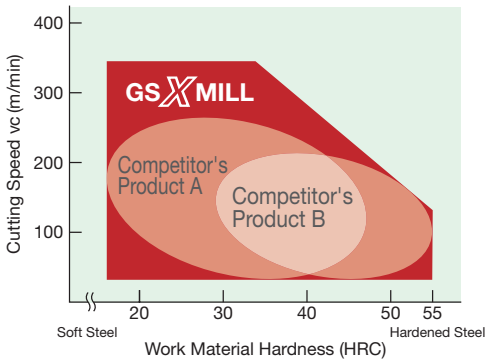

● Thermal resistance

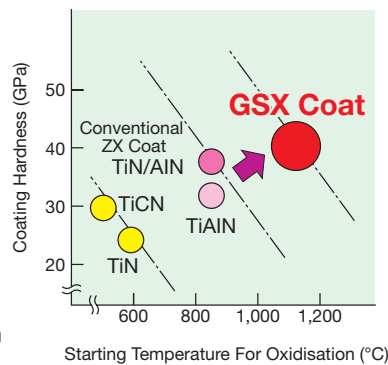

● Improved chip evacuation

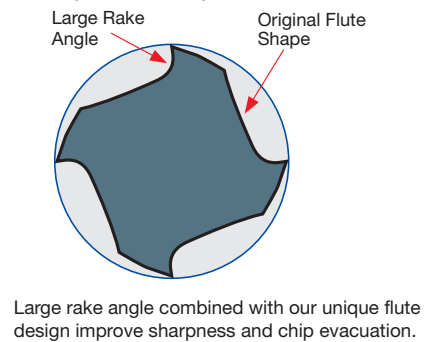

■ Expanded machining applications with 2 cutting edge corner styles

Sharp edged S type and fracture-resistant C type are available.



Sharp Corner: Sharp Edged Design S type

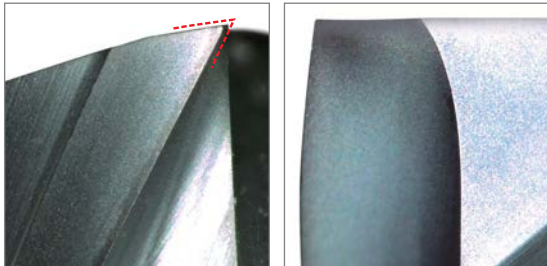

Gash Land: Fracture Resistant Design C type

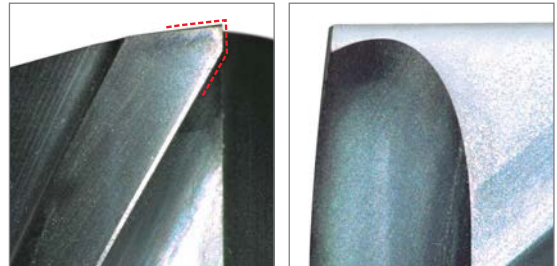

Note: When using endmills with gash land, some material remains as shown on the right. Use the S type to obtain sharp corners.

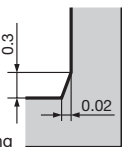

Example: Corner after $\phi 10\text{mm}$ milling (Unit: mm)

■ Work Material

◎: Best ○: Suitable Blank: Not recommended

	P				H			M	S	K	N				
	General Structural Rolled Steel	Carbon Steel	Alloy Steel	Pre-hardened Steel	Hardened Steel			Stainless Steel	Titanium Alloy	Heat-Resistant Alloy	Cast Iron	Aluminum Alloy	Copper Alloy	Graphite	CFRP
	◎	◎	◎	◎	45 to 55HRC	55 to 60HRC	60HRC	◎	○	○	○				
	○	○	○	○	±1			◎	○	○	○				

*1: GSXSLT30000C is recommended for 50 HRC or less.

■ Recommended Machining Examples (General-purpose type)

Applications	Side Milling		Groove Milling		Groove Finishing	
Form						
Cutting Edge Corner	Roughing	Finishing	Roughing	Finishing	Roughing	Finishing
S type		◎		○*2		◎
C type	◎	○	◎	◎	◎	○

The S type is best for removing inside corners.

*2: Use with small depth of cut.

GSX MILL series

Product Range

Applications	No. of Flutes	Cutting Edge Length						
		1.5D	2D		3D		4D	
		C type	S type	C type	S type	C type	S type	C type
General-purpose	2 Flutes	GSX20000C-1.5D ø0.5 to ø25.0mm →I30	GSX20000S-2D ø0.3 to ø25.0mm →I32	GSX20000C-2D ø0.5 to ø25.0mm →I36	GSX20000S-3D ø0.5 to ø25.0mm →I38	GSX20000C-3D ø0.5 to ø25.0mm →I40	GSX20000S-4D ø0.5 to ø25.0mm →I42	GSX20000C-4D ø0.5 to ø25.0mm →I44
	3 Flutes	GSX30000C-1.5D ø1.0 to ø12.0mm →I46		GSX30000C-2D ø1.0 to ø12.0mm →I48				
	4 Flutes	GSX40000C-1.5D ø1.0 to ø25.0mm →I50	GSX40000S-2D ø1.0 to ø25.0mm →I52	GSX40000C-2D ø1.0 to ø25.0mm →I54	GSX40000S-3D ø1.0 to ø25.0mm →I56	GSX40000C-3D ø1.0 to ø25.0mm →I58	GSX40000S-4D ø1.0 to ø25.0mm →I60	GSX40000C-4D ø1.0 to ø25.0mm →I62
Multi-purpose	3 Flutes	GSXSLT30000C-1.5D ø1.0 to ø12.0mm →I138						
Radius	4 Flutes		GSX40000-R-2D ø3.0 to ø12.0mm →I98					

High-efficiency Square type: GSV4000-2.5D →I70 GSXVL4000-2.5D →I72 High-efficiency Radius type: GSV4000-R-2.5D →I100 GSXVL4000-R-2.5D →I102
Ballnose type: GSXB20000 →I124

High Precision

- Endmill tolerance is reduced to 2/3 of conventional types, so diameter compensation is not required when changing tools.

Multi-purpose

- Optimised flute design of slot mill 3 flute (short) type reduces cutting force.
 - Continuous (composite) applications such as plunging and groove milling is possible
 - Perfect for use with thin plates and small machining centres.

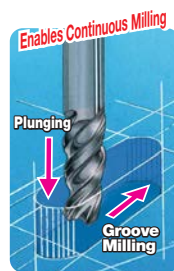

Long Cutting Edge Length with High Rigidity (C type)

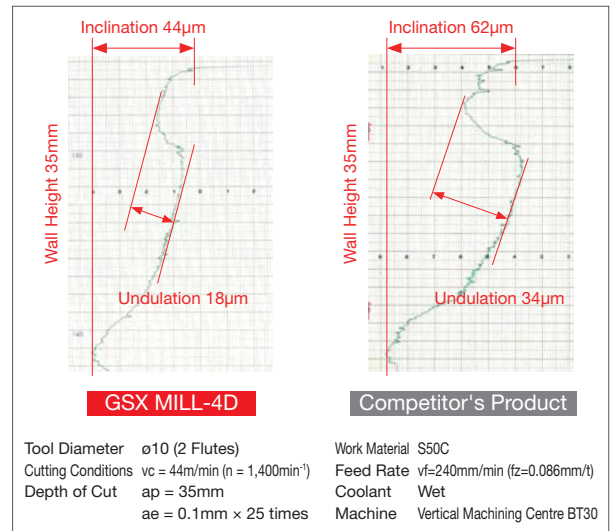

Application Examples (Square)

Carbon Steel Groove Milling with GSX20000C

Gash land for stronger cutting edge

Tool Diameter ø6 (2 Flutes)
Work Material S50C
Cutting Conditions vc=87m/min (n=4,615min⁻¹)
 vf=553mm/min (fz=0.06mm/t)
 ap=3mm
 ae=6mm
 Dry
Machine Vertical Machining Centre BT50

Cast Iron Groove Milling with GSX20000C

GSX Coat for improved wear resistance

Tool Diameter ø10 (2 Flutes)
Work Material FCD600 equivalent
Cutting Conditions vc=66m/min (n=2,100min⁻¹)
 vf=302mm/min (fz=0.072mm/t)
 ap=5mm × 5 times
 ae=10mm
 Dry
Machine Vertical Machining Centre BT40

Stainless Steel Machining with GSX20000C

Improved reliability even with wet machining

Tool Diameter ø10 (2 Flutes)
Work Material SUS304
Cutting Conditions vc=50m/min (n=1,591min⁻¹)
 vf=127mm/min (fz=0.04mm/t)
 ap=10mm
 ae=0.5mm
 Dry
Machine Vertical Machining Centre BT50

S50C Side Milling with GSX20000S

The S type delivers optimum sharpness

Tool Diameter ø6 (2 Flutes)
Work Material S50C
Cutting Conditions vc=87m/min (n=4,615min⁻¹)
 vf=553mm/min (fz=0.06mm/t)
 ap=10mm
 ae=0.3mm
 Dry
Machine Vertical Machining Centre BT50

Endmills

I

Square

Radius

Ballnose

Multi-Purpose

General-Purpose

High Efficiency

Hardened Steel

Roughing

Non-Ferrous Metal

CFRP

Coated

Uncoated

GSX MILL series

Endmills

I

Square

Radius

Ballnose

Multi-Purpose

General-Purpose

High Efficiency

Hardened Steel

Roughing

Non-Ferrous Metal

CFRP

Coated

Uncoated



Recommended Milling Examples

Applications	Side Milling		Groove Milling		Groove Finishing	
	Roughing	Finishing	Roughing	Finishing	Roughing	Finishing
GSXVL type	⊙	○	⊙	⊙	⊙	○
GSV type	⊙	⊙	○	⊙	⊙	○

Differentiating the Usage of Anti-vibration GSXVL type / GSV type

GSXVL types exhibit outstanding performance for high load milling. GSV type is both chatter-resistant and economical.

GSXVL type

Anti-Vibration High Load Milling

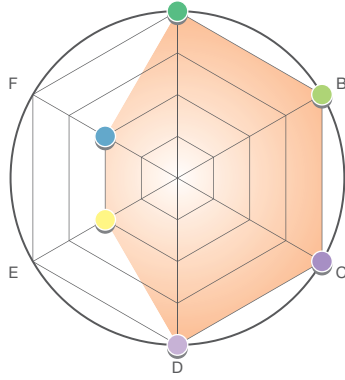

GSV type

Anti-Vibration/General-purpose Simple Re-Grinding

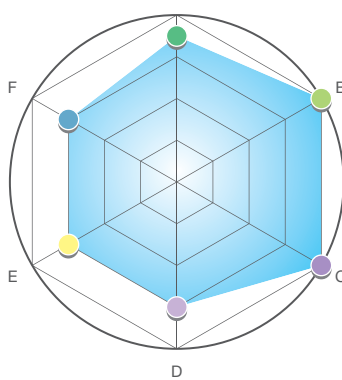

GSX type

General-purpose

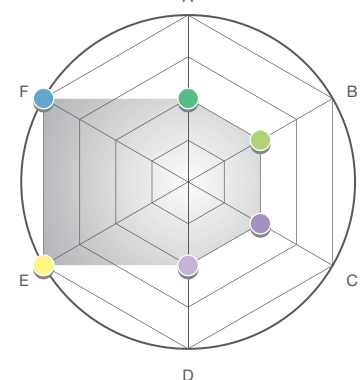

- A Chatter Resistance (Groove Milling)
- B Chatter Resistance (Side Milling)
- C Cutting Speed v_c
- D Depth of Cut a_p
- E Shoulder Accuracy
- F Economy

Application Range

Side Milling

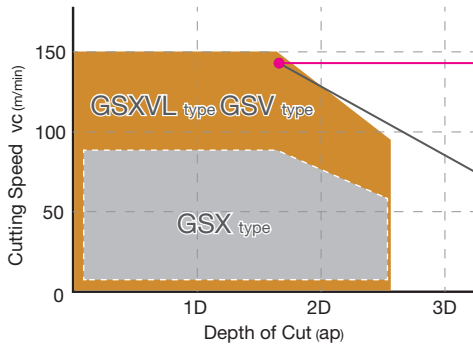

Cutting Force

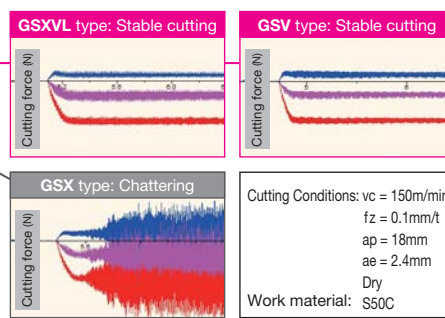

Groove Milling

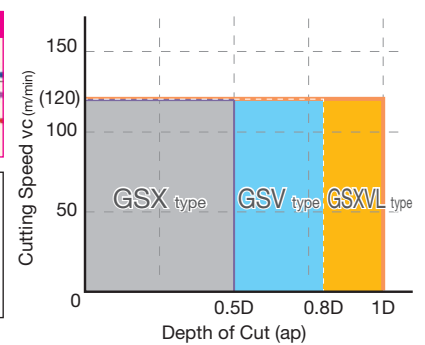

Irregular Pitch $a1^\circ \neq a2^\circ$

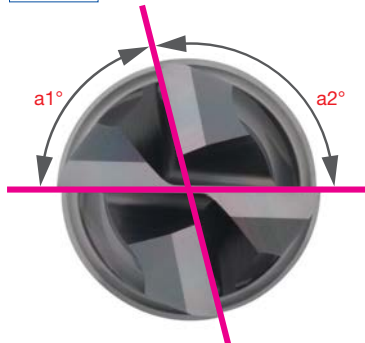

Irregular Lead $b1^\circ \neq b2^\circ$



Regular Lead $b2^\circ = b2^\circ$

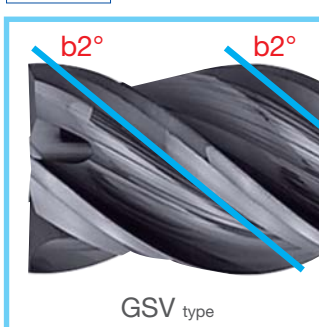

Rounded Land (Used for $\phi 6\text{mm}$ and larger sizes)

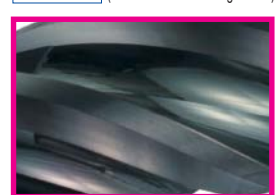

GSX MILL series

Application Examples (Anti-vibration type)



<p>(1) Side Milling GSXVL ○ / GSV type ◎</p> <p>Cutting Conditions: $vc = 102\text{m/min}$ ($n = 4,100\text{min}^{-1}$) Tool Diameter: $\phi 8$ $vf = 1,080\text{mm/min}$ (0.1mm/t) $ap = 24\text{mm}$, $ae = 2.0\text{mm}$</p>	<p>(2) High-speed Side Milling GSXVL ◎ / GSV type ◎</p> <p>Cutting Conditions: $vc = 151\text{m/min}$ ($n = 4,000\text{min}^{-1}$) Tool Diameter: $\phi 12$ $vf = 4,800\text{mm/min}$ (0.3mm/t) $ap = 12\text{mm}$, $ae = 2.0\text{mm}$</p>	<p>(3) Groove Milling GSXVL ◎ / GSV type ○</p> <p>Cutting Conditions: $vc = 90\text{m/min}$ ($n = 2,400\text{min}^{-1}$) Tool Diameter: $\phi 12$ $vf = 960\text{mm/min}$ (0.1mm/t) $ap = 12\text{mm}$</p>
<p>(4) Ramping GSXVL ◎ / GSV type ○</p> <p>Cutting Conditions: $vc = 90\text{m/min}$ ($n = 2,400\text{min}^{-1}$) Tool Diameter: $\phi 12$ $vf = 480\text{mm/min}$ (0.05mm/t) Ramp Angle 5°</p>	<p>(5) Seat Face Expansion Milling GSXVL ◎ / GSV type ◎</p> <p>Cutting Conditions: $vc = 90\text{m/min}$ ($n = 2,400\text{min}^{-1}$) Tool Diameter: $\phi 12$ $vf = 960\text{mm/min}$ (0.1mm/t)</p>	<p>(6) Helical Milling x 2 GSXVL ◎ / GSV type ◎</p> <p>Cutting Conditions: $vc = 90\text{m/min}$ ($n = 2,400\text{min}^{-1}$) Tool Diameter: $\phi 12$ $vf = 480\text{mm/min}$ (0.05mm/t) Ramp Angle 3°</p>
<p>(7) Helical Milling to Groove Expansion Milling x 2 GSXVL ◎ / GSV type ◎</p> <p>Cutting Conditions: $vc = 90\text{m/min}$ ($n = 2,400\text{min}^{-1}$) Tool Diameter: $\phi 12$ [Helical] $vf = 480\text{mm/min}$ (0.05mm/t) [Groove Expansion] $vf = 672\text{mm/min}$ (0.07mm/t) [Finishing] $vf = 1,920\text{mm/min}$ (0.2mm/t) Ramp Angle 3° $ap = 24\text{mm}$, $ae = 0.1\text{mm}$</p>		<p>(8) Engraving GSXVL ◎ / GSV type ○</p> <p>Cutting Conditions: $vc = 79\text{m/min}$ ($n = 2,100\text{min}^{-1}$) Tool Diameter: $\phi 12$ $vf = 588\text{mm/min}$ (0.07mm/t) $ap = 12\text{mm}$</p>

GSX MILL series

Endmills

I

Square

Radius

Ballnose

Multi-Purpose

General-Purpose

High Efficiency

Hardened Steel

Roughing

Non-Ferrous Metal

CFRP

Coated

Uncoated



ISO 1124

Recommended Milling Examples

Applications	Radius Milling		Profiling		Pocketing	
	Roughing	Finishing	Roughing	Finishing	Roughing	Finishing
GSXB type	◎	◎	◎	◎	◎	◎

Improved Thermal Resistance and Wear Resistance

New coating combined with an ultra-fine grained carbide substrate for better thermal and wear resistance.

Application Range

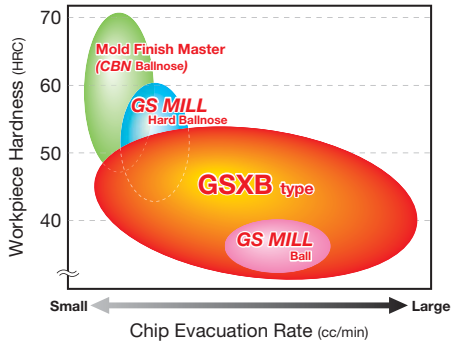

Reduced Cutting Force

Large helix angle on curved cutting edge reduces cutting force

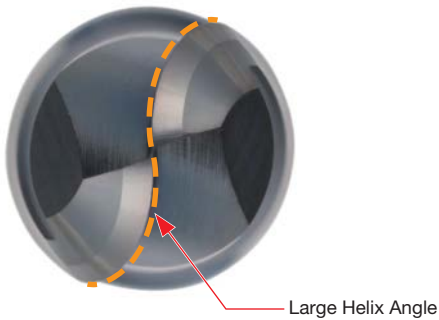

Improved Chip Evacuation

Unique pocket design and expanded pocket area promote better chip evacuation.



Application Examples

Die Steel Machining with GSXB20000

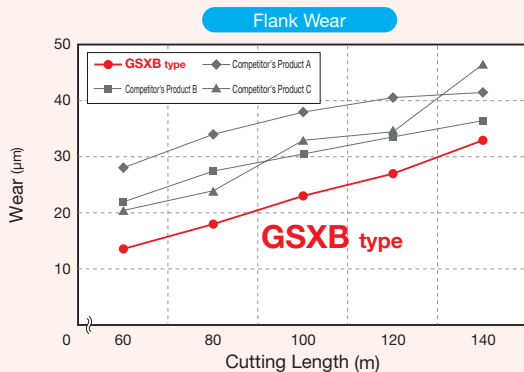

GSXB type (Cutting Length 140 m)



Able to continue

Conventional Tool (Cutting Length 80 m)



Unable to continue

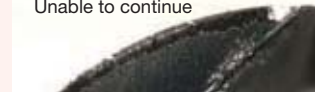

Breakage at the centre, severe wear on rake face

Work Material: SKD61 (50HRC)

Tool Diameter: R3.0 (2 Flutes)

Cutting Conditions: $vc = 179\text{m/min}$ ($n = 9,500\text{min}^{-1}$), $vf = 2,250\text{mm/min}$ ($fz = 0.12\text{mm/t}$)

$ap = 0.2$ to 1.0mm , $pf = 0.3\text{mm}$, Wet

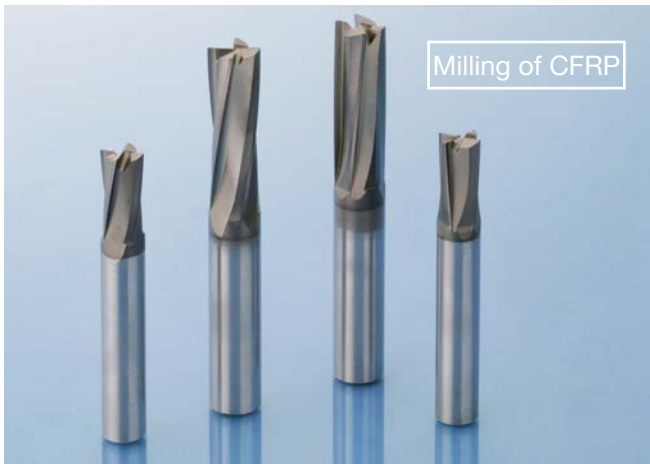

Equipment: Vertical Machining Centre BT40

SUMIDIA Coated SSDC series



I97

Product Range

Cat. No.	No. of Flutes	Shape	Diameter (mm)
SSDC 4000	4 Flutes	Right-hand Helix  I97	ø6 to ø12
SSDC 4000RL	4 Flutes	Right-Left-hand Helix  I97	ø6 to ø12

Performance

Surface Finish Comparison

SSDC type

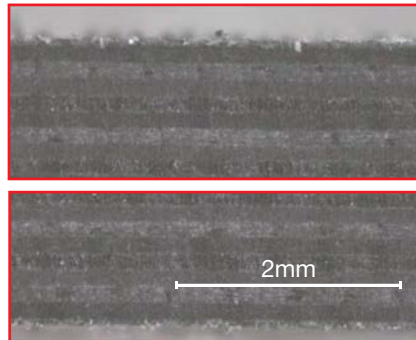
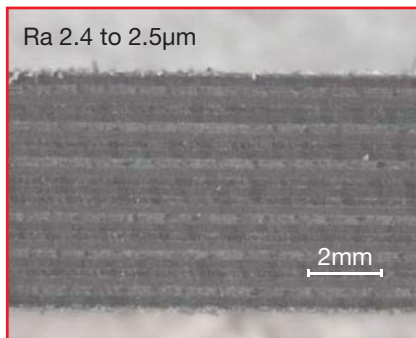

Competitor's Product

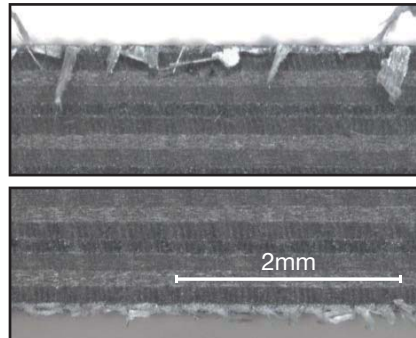
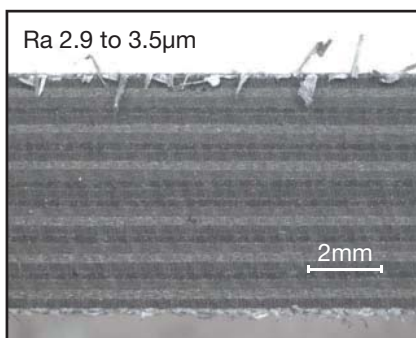

Work Material: CFRP
 Tool Diameter: ø10 (4 Flutes)
 Cutting Conditions: $v_c=314\text{m/min}$
 $(n = 10,000\text{min}^{-1})$
 $v_f = 1,000\text{mm/min}$
 $(f_z = 0.025\text{mm/t})$
 Dry

Results

SSDC type

High surface quality with no burrs

Competitor's Product

Burrs are formed.
 Low surface quality

Features and Applications

- Two different types of flute shapes are available.

SSDC type (Right-hand Helix type)

Achieving both better sharpness and longer tool life through optimising the rake and relief angles, along with a small helix angle.



SSDCRL type (Right-Left-hand Helix type)

Right-Left-hand helix prevents delamination on top and bottom surfaces.

Cutting force is dispersed even with unstable clamping, improving surface quality.



Endmills

I

Square

Radius

Ballnose

Multi-Purpose

General-Purpose

High Efficiency

Hardened Steel

Roughing

Non-Ferrous Metal

CFRP

Coated

Uncoated

SSEH series

Endmills

I

Square

Radius

Ballnose

Multi-Purpose

General-Purpose

High Efficiency

Hardened Steel

Roughing

Non-Ferrous Metal

CFRP

Coated

Uncoated



I108, I110, I119

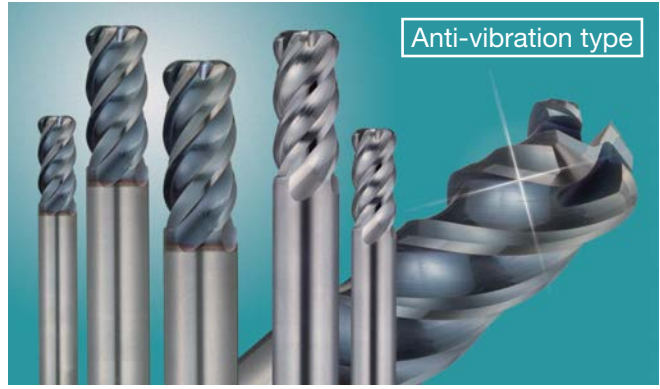

I104, I106, I118

SSEH type Radius

■ Features and Applications

- High helix (45° helix) improves sharpness.
- Combination of unique flute design and semi-mirrored rake face improves chip evacuation and adhesion resistance.
- Ultra-smooth coating with improved hardness and thermal resistance combined with tough carbide substrate improves tool life when working with heat-resistant alloys.
- Unique, smooth radius shape mitigates cutting impact and improves fracture resistance.
- Both coated and uncoated types are in stock to meet various conditions.

■ Application Examples

● Inconel 718 (Side Milling)

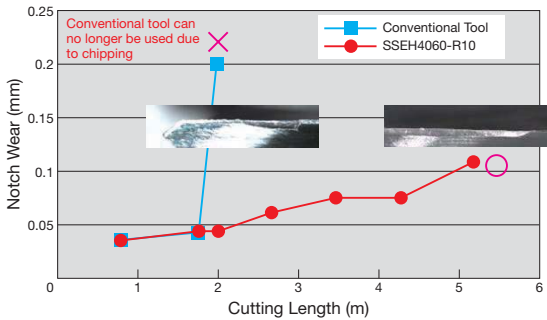

Tool Diameter: $\phi 6 \times R1$
 Cutting Conditions: $vc = 20\text{m/min}$, $fz = 0.025\text{mm/t}$,
 $ap = 5\text{mm}$, $ae = 0.5\text{mm}$ Wet

● Inconel 713 (Side Milling)

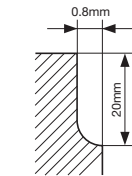

In Sumitomo Electric Hardmetal tests, the special coating with excellent adhesion resistance provided less cutting edge adhesion than the competitor's product and enabled fracture-free machining. The competitor's product suffered from edge adhesion leading to breakage.

Tool Diameter: $\phi 10 \times R1$ Number of Workpieces: 150pcs./unit
 Cutting Conditions: $vc=32\text{m/min}$, $fz=0.018\text{mm/t}$,
 $ap=20\text{mm}$, $ae=0.8\text{mm}$ Dry

Unique, smooth radius design



Original wide arc flute

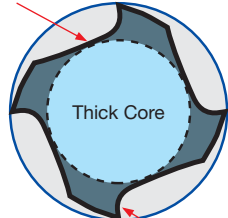

Semi-mirrored Rake Face

SSEH Radius Anti-vibration type

■ Features and Applications

- New anti-vibration type added to the SSEH type endmill for exotic alloys.
- Builds on the same features of existing endmills by adding an irregular lead for exceptional anti-vibration performance.
- Compatible with a wide range of milling for exotic alloys including SUS, Inconel and Titanium.
- Reduces chattering for high-speed, high-feed cutting.
- Both coated and uncoated types are in stock to meet various conditions.

Irregular Pitch + Irregular Lead

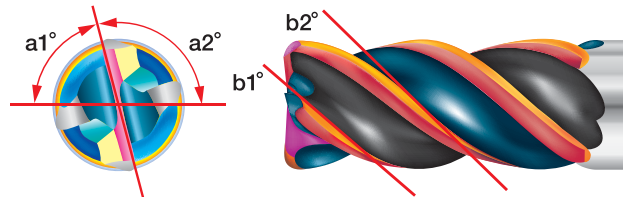

■ Application Examples

● Corner Finishing for Titanium Alloy

	SSEH Radius Anti-Vibration Endmill SSEHVL 4120W-30	No Anti-Vibration Mechanism Endmill $\phi 12 \times R3.0$
Machined Surface	No chattering	Chatter occurred
Vibration Data	Stable cutting	Increases chattering at entry point corner
Tool Breakage	No breakage	Chipping caused by chattering
Cutting Conditions: $vc = 42.4\text{m/min}$ ($n = 1,125\text{min}^{-1}$) $vf = 200\text{mm/min}$ ($fz = 0.044\text{mm/t}$) $ap = 5.0\text{mm}$, $ae = 12\text{mm}$ Wet		

Safe-Lock™ Compatible Endmill series (License by HAIMER®)



I106, I110

■ Features and Applications

- Combination with **SAFE-LOCK™** SAFE-LOCK prevents tools from coming off even during high load milling such as groove milling and roughing, and enables highly efficient machining.
- Defects are prevented because there will be no damage to workpieces from tools falling off.
- Endmill can be pushed out after regrinding so that the same tool height can be maintained. No need for overall length adjustment for milling unit.



■ SAFE-LOCK™ Applicable Products

Cat. No.	No. of Flutes	Shape	Diameter (mm)
SSEHVL 4000WS-R	4 Flutes	 Radius I106	ø12.0 to ø25.0

Cat. No.	No. of Flutes	Shape	Diameter (mm)
SSEH 4000WS-R	4 Flutes	 Radius I110	ø12.0 to ø25.0

■ SAFE-LOCK™ Applicable Holders

● Shrink-fit Chuck Holder



- High runout accuracy ensures long tool life.
- Easy setup with a dedicated shrink-fit unit.
- High rigidity provides high resistance to chattering.

● Collet Chuck Holder



- Tool change-over is simple.
- Specially designed collet provides strong grip.
- High rigidity provides high resistance to chattering.

■ Concept Illustration of Groove Milling

● SAFE-LOCK™ With Anti-fall Mechanism

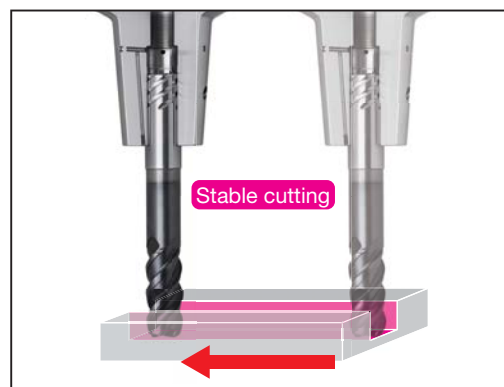

● Without Anti-fall Mechanism



Endmills

I

Square

Radius

Ballnose

Multi-Purpose

General-Purpose

High Efficiency

Hardened Steel

Roughing

Non-Ferrous Metal

CFRP

Coated

Uncoated

GS MILL Hard series

Endmills

I

Square

Radius

Ballnose

Multi-Purpose

General-Purpose

High Efficiency

Hardened Steel

Roughing

Non-Ferrous Metal

CFRP

Coated

Uncoated

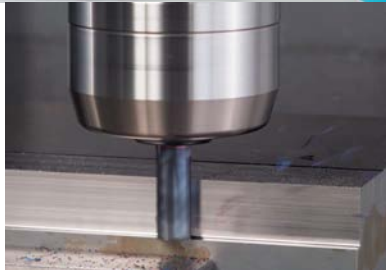

Side Milling of SKD61 (53HRC) with GS MILL Hard Radius

■ Features

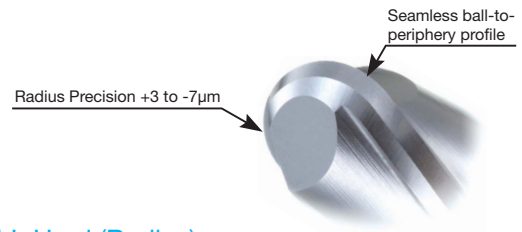

GS MILL Hard (Square/Ballnose/Radius)

- With the high-Al content Al-Ti-Cr coating GS HARD Coat, oxidation resistance is now 3 times higher at 1,100°C, thereby improving thermal and wear resistance under ultra-high speed machining conditions.
- Coating surface roughness is similar to the standard GS Coat, which reduces cutting friction while enhancing smooth cutting.
- Ultra-fine grain high-hardness cemented carbide substrate with low cobalt content has been newly developed to improve substrate strength. This increases tool durability and prevents micro-plastic deformation of the cutting edge that occurs during ultra-high speed machining.
- New unique cross-sectional design achieves better chip evacuation and tool rigidity.
- **Hard (Radius)** / New endmill series with improved fracture resistance.
- **Hard (Ballnose)** / Utilises a new coating with excellent lubricity and thermal resistance. Achieves precision finishing of hardened steel, with a precise radial tolerance of +3 to -7µm and a seamless ball to periphery profile.



■ Product Range

● GS MILL Hard (Square/Ballnose)

Cat. No.	No. of Flutes	Shape	Diameter (mm)
GSH 4000SF	4 Flutes		ø1 to ø20
GSH 6000SF	6 Flutes		
GSH 8000SF	8 Flutes		
I176, I77, I78			
GSBH 20000SF	2 Flutes		R0.2 to R6.0 (ø0.4 to ø12)
I126			

● GS MILL Hard (Radius)

Cat. No.	No. of Flutes	Shape	Diameter (mm)
GSH 6000SF-R	6 Flutes		ø6 to ø20
GSH 8000SF-R	8 Flutes		
I116, I117			

■ GS MILL Hard (Square)

● Cutting Performance (6 Flutes, ø10 Side Milling)

Work Material: SKD61(53HRC)
 Tool: GSH 6100SF (ø10)
 Cutting Length: 75m
 Cutting Conditions: $vc = 800\text{m/min}$ ($n = 25,460\text{min}^{-1}$)
 $fz = 0.07\text{ mm/t}$ ($f = 10,500\text{mm/min}$)
 $ap = 10\text{mm}$, $ae = 0.2\text{mm}$
 Dry (Air Blow), Down Cut

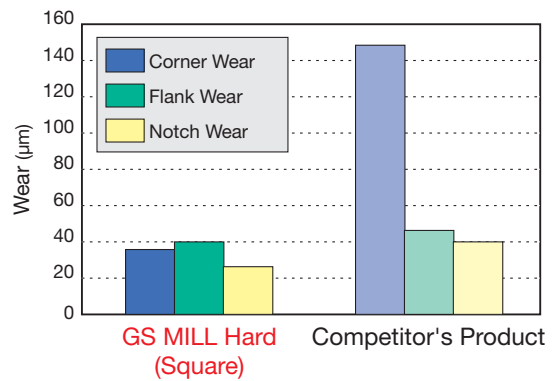
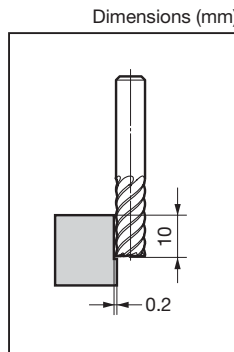

■ GS MILL Hard (Ballnose)

● Application Example (Precision Forging Die for Automotive Components)

Work Material: SKH51(62HRC)
 Tool: GSBH 20300SF (R3)
 Cutting Length: Approx. 150m
 Cutting Conditions: $vc = 75\text{m/min}$ ($n = 4,000\text{min}^{-1}$)
 $n = 4,000\text{min}^{-1}$
 $fz = 0.075\text{ mm/t}$ ($f = 600\text{mm/min}$)
 $ap = 0.16\text{mm}$, $pf = 1\text{mm}$

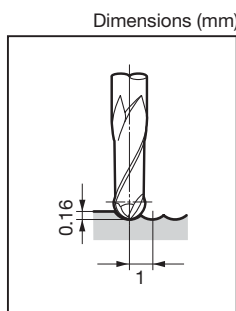

AURORA Coat Endmills



190, 191, 1127



For Copper Electrodes

1128

Features and Applications

- Very smooth AURORA Coat results in low adhesion as well as a good surface finish
- With lower cutting forces and high rigidity, this series is suitable for low rigidity machines
- Available in 2- and 4-flute square type as well as ballnose type endmills
- Added R0.05 to R2.00mm long neck ballnose endmills for machining copper electrodes

Product Range

Cat. No.	No. of Flutes	Shape	Diameter (mm)
ASM 2000DL	2 Flutes	Square	ø2 to ø16
ASM 4000DL	4 Flutes	Square	ø2 to ø16
SNB 2000DL	2 Flutes	Ballnose	R1 to R8 (ø2 to ø16)
SNB2	2 Flutes	Long Neck Ballnose	R0.05 to R2 (ø0.1 to ø4)

Performance

Comparison of Cutting Force

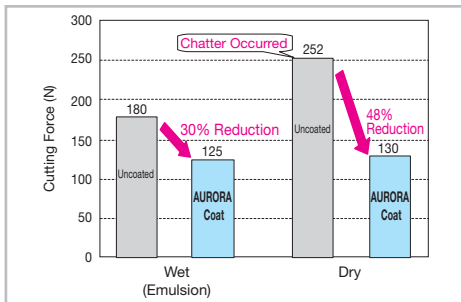

Surface Roughness Comparison

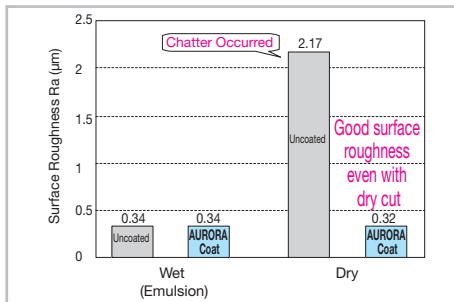

Work Material: A5052
 Tool: ASM4100DL
 ø10 (4 Flutes)
 Cutting Conditions:
 vc = 200m/min
 n = 6,300min⁻¹
 fz = 0.05mm/t
 vf = 1,300mm/min
 ap = 10mm
 ae = 1mm
 Down-cut

AURORA Coat Long Neck Ballnose Endmill SNB 2 type

- Achieves longer tool life compared with chromium nitride (CrN)-coated carbide tools
- Products with ballnose radii of 0.05 to 2.00mm
- Reduced coefficient of friction
- Extremely smooth coating layer

Tool Wear Comparison

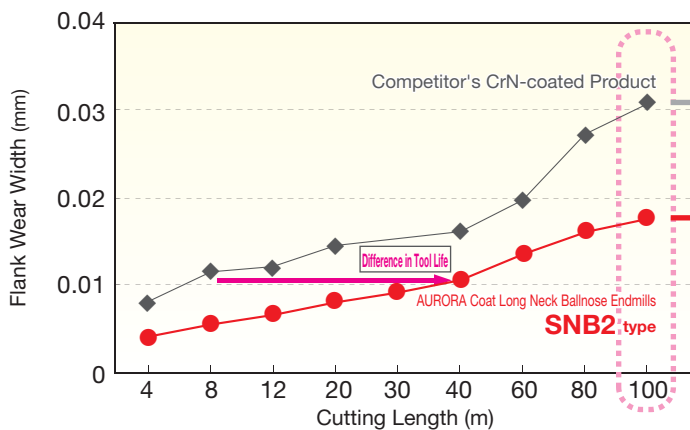

Tool	Cutting Length 100m	Cutting Conditions
Competitor's CrN-coated Product		Work Material: Tough-pitch Copper Tool: R0.3mm Ballnose Endmill Cutting Conditions: vc = 57m/min n = 30,000min ⁻¹ vf = 700mm/min ap = 0.035mm ae = 0.03mm Oil Mist
SNB2 type		

Excellent adhesion resistance in copper alloy milling with long tool life!

Mold Finish Master series



SUMIDIA BINDERLESS Endmills

NPDRS type/**NPDBS** type/**NPDB** type

SUMIDIA Coated Endmills

SDCB type

SUMIBORON Endmills

BNBR type/**BNBP** type/**BNBC** type



Endmills

I

Square

Radius

Ballnose

Multi-Purpose

General-Purpose

High Efficiency

Hardened Steel

Roughing

Non-Ferrous Metal

CFRP

Coated

Uncoated

SUMIDIA BINDERLESS Radius Endmills

NPDRS type

For Standard Finishing

ISO 1120



SUMIDIA BINDERLESS Ballnose Endmills

NPDBS type/**NPDB** type

For Standard Finishing

ISO 1130, 1131



SUMIDIA Coat Ballnose Endmills

SDCB type

For Rough/ Medium-Finishing

ISO 1132



For Finishing of Cemented Carbide and Hard Brittle Materials

For Finishing of Cemented Carbide and Hard Brittle Materials

For Rough/Medium Finishing of Cemented Carbide and Hard Brittle Materials

- Nano-polycrystalline diamond, which is harder than single-crystal diamond, is used for the cutting edge
- Enables direct engraving of cemented carbide, which is impossible for existing single-crystal or polycrystalline diamonds
- Ideal for finishing hard brittle materials, including cemented carbide. Realizes high-precision machining and long tool life
- Standard finish NPDBS type dramatically reduces machining cost
- Precision finish NPDB type prevents deformation by eliminating polishing process

- Realizes high-efficiency rough/medium finishing of carbide molds
- Newly developed diamond coating exhibits stable tool life
- Achieves the highest level of precision when used in combination with SUMIDIA BINDERLESS endmills

SUMIBORON Radius Endmills

BNBR type

ISO 1122



SUMIBORON Ballnose Endmills

BNBP type

ISO 1134



For Hardened Steel

For Hardened Steel

- Achieves longer tool life in high-speed, high-precision machining from pre-hardened steel to high-hardness steel in excess of 60HRC.
- Excellent machined surface quality drastically reduces the grinding process.
- Edge design suited for profiling and face milling plus an extensive selection of grades allows a wide range of machining applications.

SUMIBORON Ballnose Endmills

BNBC type

ISO 1136



For Copper Electrodes

- Ballnose radii of R0.1mm to R0.5mm are available in this series
- Utilising a high CBN content grade provides excellent edge sharpness and wear resistance
- Achieves high quality milling with high precision cutting edge

Mold Finish Master series



SUMIDIA BINDERLESS Radius Endmills

NPDRS type

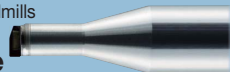

Hard Brittle Material



SUMIDIA BINDERLESS Ballnose Endmills

NPDBS type/**NPDB** type

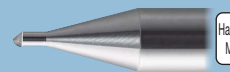

Hard Brittle Material

General Features

SUMIDIA BINDERLESS is polycrystalline diamond that directly binds nano-sized diamond particles with high strength without using any binders. Harder than single-crystal diamond, it has no cleavability, enabling machining of hard brittle material such as cemented carbide and making new machining methods possible.

Features

- SUMIDIA BINDERLESS is a pure diamond material, but unlike single-crystal diamonds, it has no anisotropy. It therefore displays excellent wear resistance with less uneven wear.
- Thanks to its polycrystalline structure, SUMIDIA BINDERLESS does not have the cleavability peculiar to single-crystal diamonds and displays excellent fracture resistance.

● Pocketing

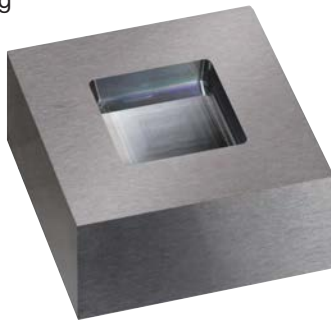

Work Material	: Cemented Carbide VF20 (Ultra-fine Grain AF1, 92.5HRA)
Machining Application	: 10mm x 10mm x depth 2mm
Tool	: NPDRS 1100R005-030 ($\phi 1$ x Corner Radius R0.05mm)
Cutting Conditions	: $n = 40,000\text{min}^{-1}$, $vf = 200\text{mm/min}$ $pf = 0.005\text{mm}$ Oil Mist
Surface Roughness	: Ra 0.015 μm
Cutting Time	: 2 Hours

● Application to Medical Use (μ -TAS Mold)



Work Material	: Cemented Carbide VF20 (Ultra-fine Grain AF1, 92.5HRA)
Tool	: NPDB 1030-010 (Ballnose Radius R0.3mm)
Cutting Conditions	: $n = 38,000\text{min}^{-1}$, $vf = 95\text{mm/min}$ $pf = 0.001\text{mm}$ Wet (Oil-based)
Machining Allowance	: 0.003mm
Surface Roughness	: Ra 0.016 to 0.020 μm
Machining Distance	: 8.3m
Cutting Time	: Finishing 1 Hour 28 Minutes

Hardness

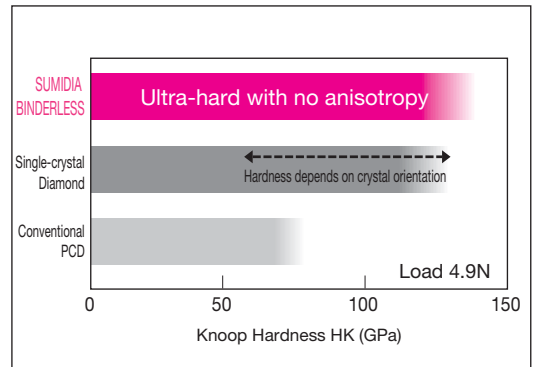

● Hemispherical Surface Milling

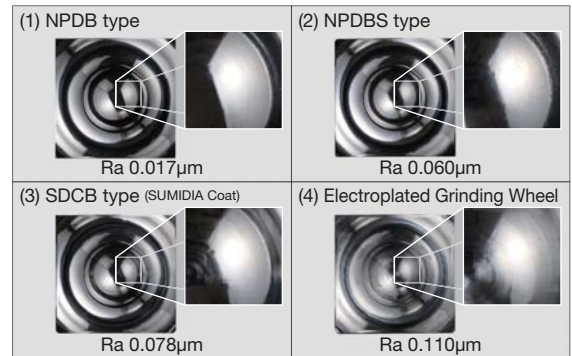

Work Material	: Cemented Carbide VF20 (Ultra-fine Grain AF1, 92.5HRA)
Machining Application	: $\phi 6$ (Hemispherical Surface Milling)
Tool	: (1) NPDB 1050-020 (Ballnose Radius R0.5mm) (2) NPDBS 1050-020 (Ballnose Radius R0.5mm) (3) SDCB 2R050-020 (Ballnose Radius R0.5mm) (4) R0.5, #400
Cutting Conditions	: $n = 40,000\text{min}^{-1}$, $vf = 120\text{mm/min}$ $pf = 0.005\text{mm}$ Oil Mist
Cutting Time	: 1 Hour 30 Minutes

● Application to Optical Use (Fly-Eye Lens Mold)



Work Material	: Cemented Carbide VF20 (Ultra-fine Grain AF1, 92.5HRA)
Tool	: Finishing: NPDB 1050-020 (Ballnose Radius R0.5mm) Roughing: Diamond-Coated Endmill (Ballnose Radius R0.5mm)
Cutting Conditions	: $n = 60,000\text{min}^{-1}$, $vf = 300\text{mm/min}$ $pf = 0.005\text{mm}$ Oil Mist
Surface Roughness	: Ra 0.015 μm
Cutting Time	: Finishing 2 Hours 40 Minutes Roughing 55 Minutes

Endmills



Square

Radius

Ballnose

Multi-Purpose

General-Purpose

High Efficiency

Hardened Steel

Roughing

Non-Ferrous Metal

CFRP

Coated

Uncoated

Mold Finish Master series

Endmills

I

Square

Radius

Ballnose

Multi-Purpose

General-Purpose

High Efficiency

Hardened Steel

Roughing

Non-Ferrous Metal

CFRP

Coated

Uncoated



- Realizes high-efficiency roughing/medium finishing of carbide molds
- Newly developed diamond coating exhibits stable tool life
- Achieves the highest level of precision when used in combination with SUMIDIA BINDERLESS endmills

- $\phi 10$ mm hemispherical machining

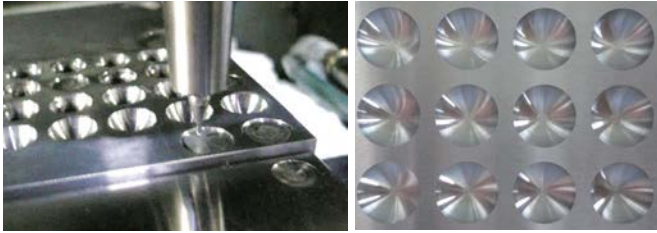

Work Material: Cemented Carbide AF1 (Ultra-Fine Grained Carbide)
 Tool: SDCB 2R100-060
 Cutting Conditions: $n = 30,000\text{min}^{-1}$, $vf = 300\text{mm/min}$
 $ae = 0.3\text{mm}$, $ap = 0.1\text{mm}$ Air Blow

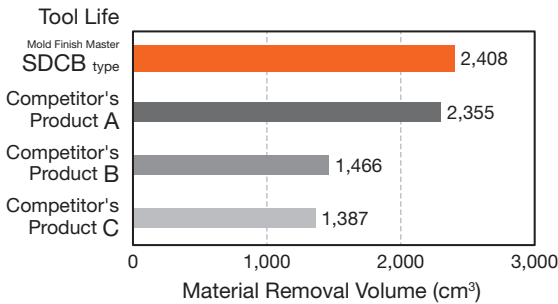

- $\phi 2.0$ (ball radius R1.0mm) number of workpieces and tool damage (delamination)

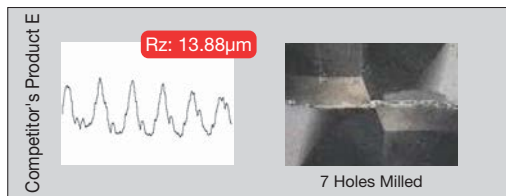
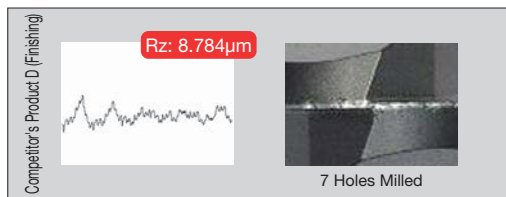
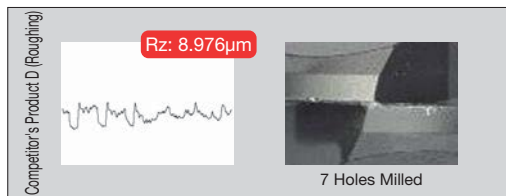
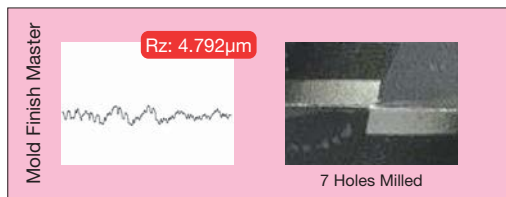

- Improved machined surface quality through use of a wiper edge (available on $\phi 1.0\text{mm}$ drills and larger).

Machined Surface Comparison

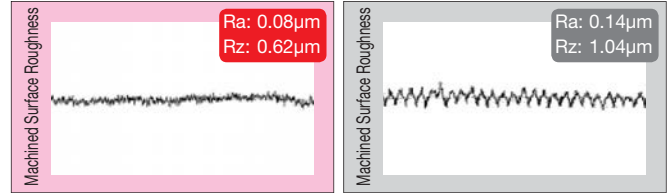

With Wiper Edge

Without Wiper Edge

- Achieving longer tool life with the combination of SUMIBORON BNX20, which has excellent wear resistance, and an optimised cutting edge design.

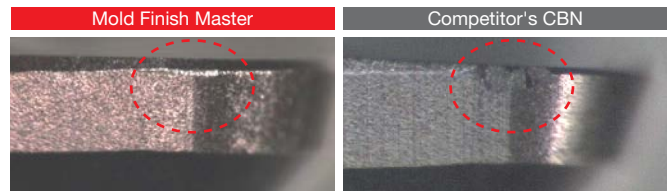

Small amount of wear

Breakage

Work Material: STAVAX (52HRC)
 Tool: BNBR 2D200R050-0604 ($\phi 2$ x Corner Radius R0.5mm)
 Cutting Conditions: $n = 20,000\text{min}^{-1}$, $vf = 400\text{mm/min}$
 $ap = 0.03\text{mm}$, $pf = 0.70\text{mm}$ Oil Mist

- Excellent wear resistance delivers almost 10 times longer tool life than carbide endmills.

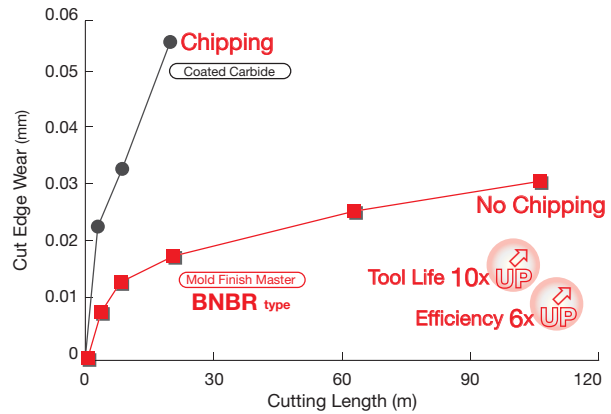

Tool Wear Comparison

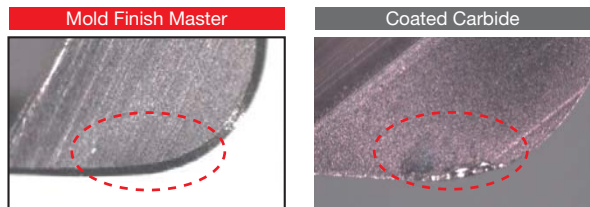

Small amount of wear

Breakage

Work Material: STAVAX (52HRC)
 Tool: BNBR 2D200R050-0604 ($\phi 2$ x Corner Radius R0.5mm)
Mold Finish Master
 Cutting Conditions: $n = 20,000\text{min}^{-1}$, $vf = 800\text{mm/min}$
 $ap = 0.03\text{mm}$, $pf = 0.70\text{mm}$ Oil Mist
Coated Carbide
 Cutting Conditions: $n = 4,800\text{min}^{-1}$, $vf = 120\text{mm/min}$
 $ap = 0.03\text{mm}$, $pf = 0.70\text{mm}$ Oil Mist

Mold Finish Master series

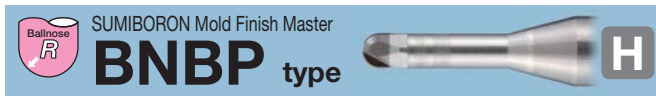

- Achieves high-precision machining with precise ball radius of $\pm 0.005\text{mm}$.
- Achieving stable interrupted milling with the combination of SUMIBORON BN350, which has excellent fracture resistance, and a cutting edge with a negative rake angle design.

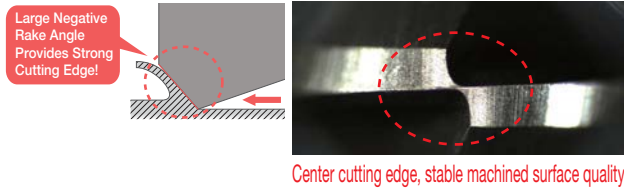

- Strong cutting edge enables use in roughing applications



Work Material: STAVAX (52HRC)
 Tool: BNPB 2R100-0554 (Ballnose Radius R0.1mm)
 Cutting Conditions: $n = 25,000\text{min}^{-1}$, $vf = 1,500\text{mm/min}$
 $ap = 0.10\text{mm}$, $pf = 0.20\text{mm}$ Oil Mist

- Excellent wear resistance and machined surface quality

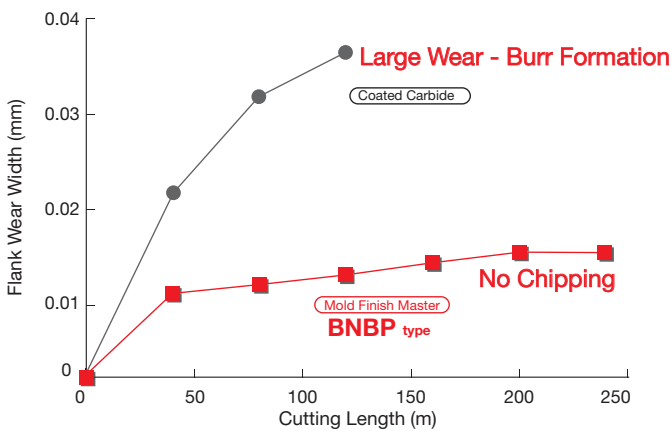

Tool Wear Comparison

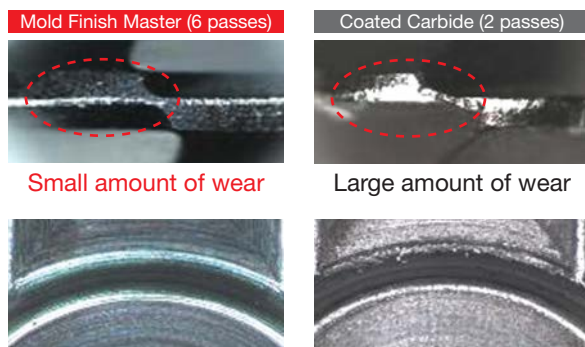

Work Material: STAVAX (52HRC)
 Tool: BNPB 2R030-0154 (Ballnose Radius R0.3mm)
 Cutting Conditions: $n = 25,000\text{min}^{-1}$, $vf = 1,500\text{mm/min}$
 $ap = 0.05\text{mm}$, $pf = 0.10\text{mm}$ Oil Mist

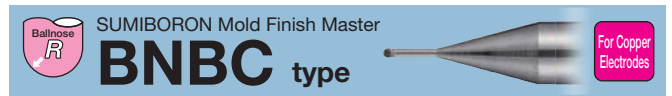

- Ballnose radii of 0.1 to 0.5mm are available in this series.
- Achieves high quality milling with high precision cutting edge.

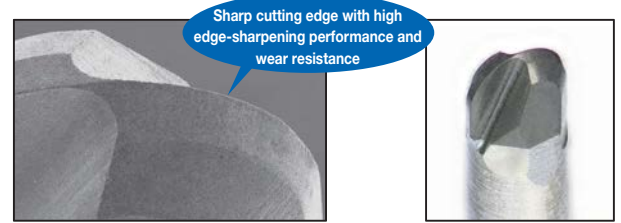

- Achieves further improved tool life

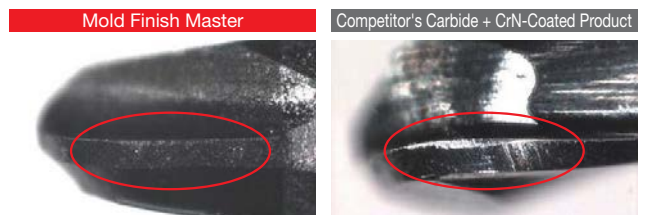

Work Material: Tough-pitch Copper (Side Milling)
 Tool: BNBC 2R030-0304 (Ballnose Radius R0.3mm)
 Cutting Conditions: $n = 30,000\text{min}^{-1}$, $vf = 700\text{mm/min}$
 $ap = 0.035\text{mm}$, $ae = 0.03\text{mm}$ Oil Mist

- Utilisation of high CBN content grade promotes excellent edge sharpness and wear resistance

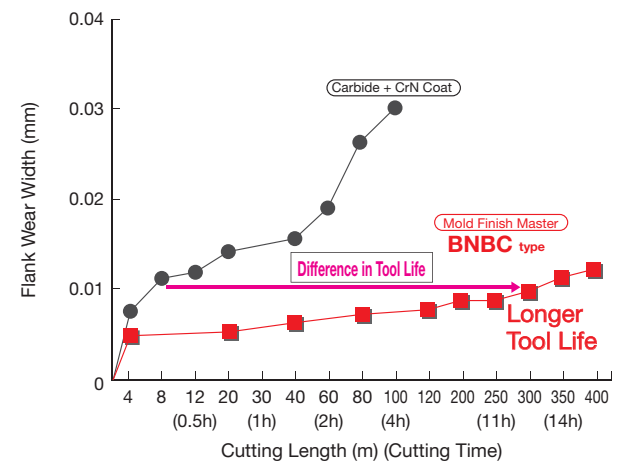

Tool Wear Comparison

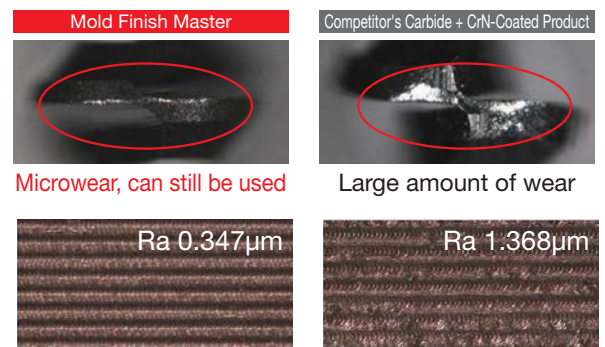

Work Material: Tough-pitch Copper
 Tool: BNBC 2R030-0304 (Ballnose Radius R0.3mm)
 Cutting Conditions: $vc = 57\text{m/min}$, $n = 30,000\text{min}^{-1}$
 $fz = 0.007\text{mm/t}$, $vf = 400\text{mm/min}$
 $ap = 0.005\text{mm}$, $ae = 0.05\text{mm}$ Oil Mist

GSX 2000C-1.5D type

- General Steel
- Carbon Steel
- Alloy Steel
- Pre-hardened Steel
- Tempered Steel / Die Steel
- Hardened Steel 45 to 55HRC
- Hardened Steel 55 to 60HRC
- Stainless Steel
- Ti Alloy / Heat Resistant Alloy
- Cast Iron

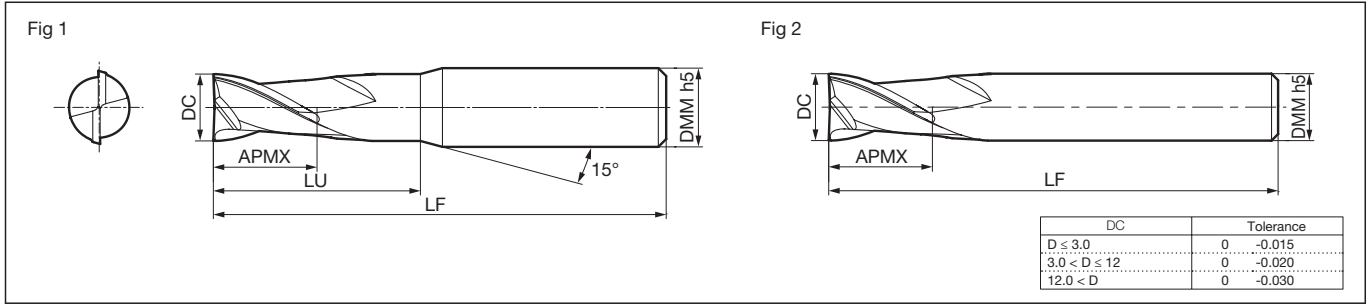

Body Dimensions (mm)

Cat. No.	Stock	Dia. DC	Cutting Edge Length APMX	Neck Length LU	Overall Length LF	Shank Dia. DMM	Fig
GSX 20050C-1.5D	●	0.5	1.0	1.4	40	4	1
20100C-1.5D	●	1.0	1.5	2.5	40	4	1
20150C-1.5D	●	1.5	2.3	3.3	40	4	1
20200C-1.5D	●	2.0	3.0	4.0	40	4	1
20250C-1.5D	●	2.5	3.8	4.8	40	4	1
GSX 20300C-1.5D	●	3.0	4.5	6.0	45	6	1
20350C-1.5D	●	3.5	5.3	6.8	45	6	1
20400C-1.5D	●	4.0	6.0	7.5	45	6	1
20450C-1.5D	●	4.5	6.8	8.3	50	6	1
20500C-1.5D	●	5.0	7.5	9.5	50	6	1
GSX 20550C-1.5D	●	5.5	8.3	10.3	50	6	1
20600C-1.5D	●	6.0	9.0	—	50	6	2
20650C-1.5D	●	6.5	10.0	12.0	60	8	1
20700C-1.5D	●	7.0	11.0	13.0	60	8	1
20750C-1.5D	●	7.5	12.0	14.0	60	8	1
GSX 20800C-1.5D	●	8.0	12.0	—	60	8	2
20850C-1.5D	●	8.5	13.0	15.0	70	10	1
20900C-1.5D	●	9.0	14.0	16.0	70	10	1
20950C-1.5D	●	9.5	15.0	17.0	70	10	1
21000C-1.5D	●	10.0	15.0	—	70	10	2
GSX 21050C-1.5D	●	10.5	16.0	18.5	75	12	1
21100C-1.5D	●	11.0	17.0	19.5	75	12	1
21150C-1.5D	●	11.5	18.0	20.5	75	12	1
21200C-1.5D	●	12.0	18.0	—	75	12	2
21300C-1.5D	●	13.0	20.0	23.5	90	16	1
GSX 21400C-1.5D	●	14.0	21.0	24.5	90	16	1
21500C-1.5D	●	15.0	23.0	26.5	90	16	1
21600C-1.5D	●	16.0	24.0	—	90	16	2
21700C-1.5D	●	17.0	26.0	30.5	100	20	1
21800C-1.5D	●	18.0	27.0	31.5	100	20	1
GSX 21900C-1.5D	●	19.0	29.0	33.5	100	20	1
22000C-1.5D	●	20.0	30.0	—	100	20	2
22500C-1.5D	●	25.0	38.0	—	120	25	2

Grade: ACF20

Identification Code

GSX 2 1000 C - 1.5D

Series Code No. of Flutes Dia. Corner Style Cutting Edge Length
 C: Gash Land

Endmills

Square

Radius

Ballnose

Multi-Purpose

General-Purpose

High Efficiency

Hardened Steel

Roughing

Non-Ferrous Metal

CFRP

Coated

Uncoated

GSX 20000C-1.5D type

Recommended Cutting Conditions

1. For stable machining performance use rigid, high-precision machines and holders.
2. Use air blow when dry machining.
3. Use wet machining for stainless steel, heat-resistant alloy, and titanium alloy applications.
4. If the machine cannot achieve the recommended spindle speed, please use the maximum spindle speed available.

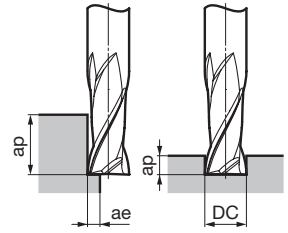

Side Milling

Work Material Cutting Conditions	Structural Steel SS		Carbon Steel SC (150 to 250HB)		Cast Iron FC		Alloy Steel SCM (25 to 35HRC)		Tempered Steel, Hardened Steel NAK, HPM (35 to 45HRC)		Hardened Steel (45 to 55HRC)		Stainless Steel SUS304,SUS316		Heat-Resistant Alloy Titanium Alloy	
	Spindle Speed (min ⁻¹)	Feed Rate (mm/min)	Spindle Speed (min ⁻¹)	Feed Rate (mm/min)	Spindle Speed (min ⁻¹)	Feed Rate (mm/min)	Spindle Speed (min ⁻¹)	Feed Rate (mm/min)	Spindle Speed (min ⁻¹)	Feed Rate (mm/min)	Spindle Speed (min ⁻¹)	Feed Rate (mm/min)	Spindle Speed (min ⁻¹)	Feed Rate (mm/min)	Spindle Speed (min ⁻¹)	Feed Rate (mm/min)
DC (mm)																
1.0	19,600	250	19,600	250	19,600	250	18,300	180	12,700	100	9,000	60	11,000	70	9,000	50
2.0	11,200	340	11,200	340	11,200	340	10,500	240	7,300	130	5,300	80	6,400	90	5,300	70
4.0	6,400	460	6,400	460	6,400	460	6,000	320	4,200	180	3,000	110	3,600	120	3,000	90
6.0	4,600	560	4,600	560	4,600	560	4,300	400	3,000	210	2,200	130	2,700	140	2,200	100
8.0	3,400	560	3,400	560	3,400	560	3,200	400	2,200	210	1,600	130	2,000	140	1,600	100
10.0	2,800	560	2,800	560	2,800	560	2,600	400	1,800	210	1,300	130	1,600	140	1,300	100
12.0	2,300	560	2,300	560	2,300	560	2,200	400	1,500	210	1,100	130	1,300	140	1,100	100
16.0	1,700	450	1,700	450	1,700	450	1,600	320	1,100	180	800	100	1,000	110	800	85
20.0	1,350	380	1,350	380	1,350	380	1,300	280	900	160	650	90	800	100	650	75
25.0	1,080	300	1,080	300	1,080	300	1,040	220	720	130	520	70	640	80	520	60
Standard Depth of Cut	ap	1.5DC										1.0DC				
	ae	0.05DC										0.02DC				

Groove Milling

Work Material Cutting Conditions	Structural Steel SS		Carbon Steel SC (150 to 250HB)		Cast Iron FC		Alloy Steel SCM (25 to 35HRC)		Tempered Steel, Hardened Steel NAK, HPM (35 to 45HRC)		Hardened Steel (45 to 55HRC)		Stainless Steel SUS304,SUS316		Heat-Resistant Alloy Titanium Alloy	
	Spindle Speed (min ⁻¹)	Feed Rate (mm/min)	Spindle Speed (min ⁻¹)	Feed Rate (mm/min)	Spindle Speed (min ⁻¹)	Feed Rate (mm/min)	Spindle Speed (min ⁻¹)	Feed Rate (mm/min)	Spindle Speed (min ⁻¹)	Feed Rate (mm/min)	Spindle Speed (min ⁻¹)	Feed Rate (mm/min)	Spindle Speed (min ⁻¹)	Feed Rate (mm/min)	Spindle Speed (min ⁻¹)	Feed Rate (mm/min)
DC (mm)																
1.0	19,600	200	19,600	250	19,600	250	18,300	180	12,700	100	9,000	60	11,000	50	4,500	20
2.0	11,200	270	11,200	340	11,200	340	10,500	240	7,300	130	5,300	80	6,400	65	2,650	25
4.0	6,400	370	6,400	460	6,400	460	6,000	320	4,200	180	3,000	110	3,600	80	1,500	35
6.0	4,600	450	4,600	560	4,600	560	4,300	400	3,000	210	2,200	130	2,700	100	1,100	40
8.0	3,400	450	3,400	560	3,400	560	3,200	400	2,200	210	1,600	130	2,000	100	800	40
10.0	2,800	450	2,800	560	2,800	560	2,600	400	1,800	210	1,300	130	1,600	100	650	40
12.0	2,300	450	2,300	560	2,300	560	2,200	400	1,500	210	1,100	130	1,300	100	500	40
16.0	1,700	360	1,700	450	1,700	450	1,600	320	1,100	180	800	100	1,000	80	400	35
20.0	1,350	300	1,350	380	1,350	380	1,300	280	900	160	650	90	800	70	320	30
25.0	1,080	240	1,080	304	1,080	304	1,040	224	720	128	520	72	640	56	256	24
Standard Depth of Cut	ap	0.2DC		0.5DC				0.2DC		0.05DC		0.2DC				

Endmills

I

Square

Radius

Ballnose

Multi-Purpose

General-Purpose

High Efficiency

Hardened Steel

Roughing

Non-Ferrous Metal

CFRP

Coated

Uncoated

GSX 20000S-2D type

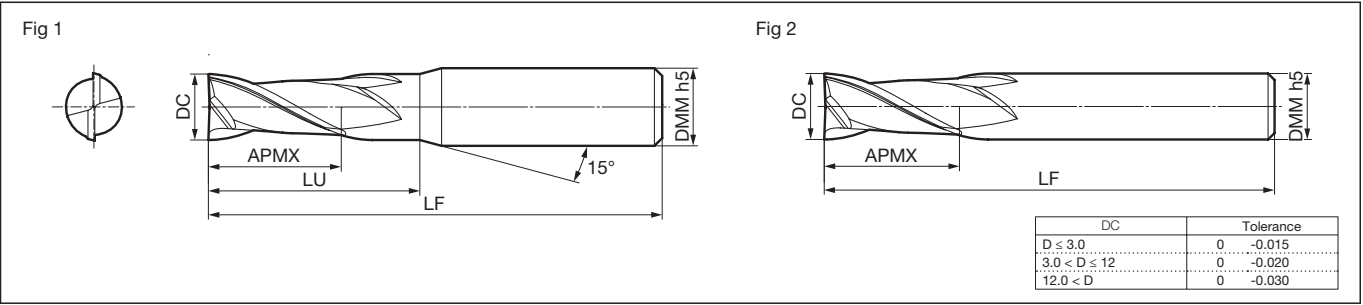
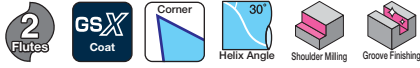

Body (Diameter ø0.3 to 4.3mm)

Dimensions (mm)

Cat. No.	Stock	Dia. DC	Cutting Edge Length APMX	Neck Length LU	Overall Length LF	Shank Dia. DMM	Fig
GSX 20030S-2D	●	0.3	0.6	1.0	40	4	1
20040S-2D	●	0.4	0.8	1.2	40	4	1
20050S-2D	●	0.5	1.3	1.7	40	4	1
20060S-2D	●	0.6	1.3	1.8	40	4	1
20070S-2D	●	0.7	1.4	1.9	40	4	1
GSX 20080S-2D	●	0.8	1.6	2.1	40	4	1
20090S-2D	●	0.9	1.8	2.3	40	4	1
20100S-2D	●	1.0	2.5	3.5	40	4	1
20110S-2D	●	1.1	2.5	3.5	40	4	1
20120S-2D	●	1.2	2.5	3.5	40	4	1
GSX 20130S-2D	●	1.3	2.6	3.6	40	4	1
20140S-2D	●	1.4	2.8	3.8	40	4	1
20150S-2D	●	1.5	3.8	4.8	40	4	1
20150S-2D-S3	●	1.5	3.8	4.8	38	3	1
20160S-2D	●	1.6	3.8	4.8	40	4	1
GSX 20170S-2D	●	1.7	3.8	4.8	40	4	1
20180S-2D	●	1.8	3.8	4.8	40	4	1
20190S-2D	●	1.9	3.8	4.8	40	4	1
20200S-2D	●	2.0	5.0	6.0	40	4	1
20200S-2D-S3	●	2.0	5.0	6.0	38	3	1
GSX 20210S-2D	●	2.1	6.0	7.0	40	4	1
20220S-2D	●	2.2	6.0	7.0	40	4	1
20230S-2D	●	2.3	6.0	7.0	40	4	1
20240S-2D	●	2.4	6.0	7.0	40	4	1
20250S-2D	●	2.5	6.3	7.3	40	4	1
GSX 20260S-2D	●	2.6	7.0	8.0	40	4	1
20270S-2D	●	2.7	7.0	8.0	40	4	1
20280S-2D	●	2.8	7.0	8.0	40	4	1
20290S-2D	●	2.9	7.0	8.0	40	4	1
20300S-2D	●	3.0	7.5	9.0	45	6	1
GSX 20300S-2D-S3	●	3.0	7.5	—	38	3	2
20310S-2D	●	3.1	7.5	9.0	45	6	1
20320S-2D	●	3.2	7.5	9.0	45	6	1
20330S-2D	●	3.3	7.5	9.0	45	6	1
20340S-2D	●	3.4	7.5	9.0	45	6	1
GSX 20350S-2D	●	3.5	8.8	10.3	45	6	1
20360S-2D	●	3.6	8.8	10.3	45	6	1
20370S-2D	●	3.7	8.8	10.3	45	6	1
20380S-2D	●	3.8	8.8	10.3	45	6	1
20390S-2D	●	3.9	8.8	10.3	45	6	1
GSX 20400S-2D	●	4.0	11.0	14.0	45	6	1
20400S-2D-S4	●	4.0	11.0	—	45	4	2
20410S-2D	●	4.1	11.0	14.0	45	6	1
20420S-2D	●	4.2	11.0	14.0	45	6	1
20430S-2D	●	4.3	11.0	14.0	45	6	1

Grade: ACF20

Endmills

I

Square

Radius

Ballnose

Multi-Purpose

General-Purpose

High Efficiency

Hardened Steel

Roughing

Non-Ferrous Metal

CFRP

Coated

Uncoated

GSX 20000S-2D type

- General Steel
- Carbon Steel
- Alloy Steel
- Pre-hardened Steel
- Tempered Steel / Die Steel
- Hardened Steel 45 to 55HRC
- Hardened Steel 55 to 60HRC
- Stainless Steel
- Ti Alloy / Heat Resistant Alloy
- Cast Iron

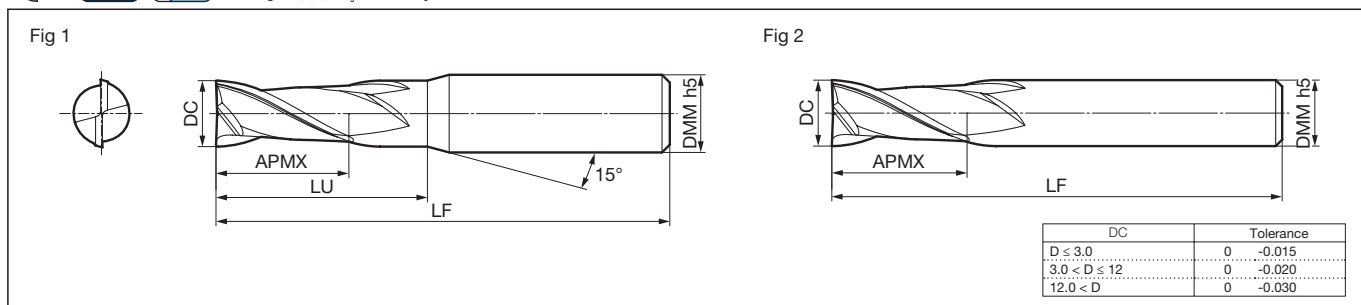
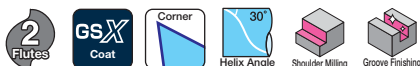

Body (Diameter ø4.4 to 8.8mm)

Dimensions (mm)

Cat. No.	Stock	Dia. DC	Cutting Edge Length APMX	Neck Length LU	Overall Length LF	Shank Dia. DMM	Fig
GSX 20440S-2D	●	4.4	11.0	14.0	45	6	1
20450S-2D	●	4.5	11.3	12.8	50	6	1
20460S-2D	●	4.6	11.3	12.8	50	6	1
20470S-2D	●	4.7	11.3	12.8	50	6	1
20480S-2D	●	4.8	11.3	12.8	50	6	1
GSX 20490S-2D	●	4.9	11.3	12.8	50	6	1
20500S-2D	●	5.0	13.0	19.6	50	6	1
20510S-2D	●	5.1	13.0	19.6	50	6	1
20520S-2D	●	5.2	13.0	19.6	50	6	1
20530S-2D	●	5.3	13.0	19.6	50	6	1
GSX 20540S-2D	●	5.4	13.0	19.6	50	6	1
20550S-2D	●	5.5	13.0	19.6	50	6	1
20560S-2D	●	5.6	13.0	19.6	50	6	1
20570S-2D	●	5.7	13.0	19.6	50	6	1
20580S-2D	●	5.8	13.0	19.6	50	6	1
GSX 20590S-2D	●	5.9	13.0	19.6	50	6	1
20600S-2D	●	6.0	13.0	—	50	6	2
20610S-2D	●	6.1	13.0	19.6	50	8	1
20620S-2D	●	6.2	13.0	19.6	50	8	1
20630S-2D	●	6.3	13.0	19.6	50	8	1
GSX 20640S-2D	●	6.4	13.0	19.6	50	8	1
20650S-2D	●	6.5	13.0	19.6	60	8	1
20660S-2D	●	6.6	13.2	19.8	60	8	1
20670S-2D	●	6.7	13.4	20.0	60	8	1
20680S-2D	●	6.8	13.6	20.2	60	8	1
GSX 20690S-2D	●	6.9	13.8	20.4	60	8	1
20700S-2D	●	7.0	16.0	21.1	60	8	1
20710S-2D	●	7.1	16.0	21.1	60	8	1
20720S-2D	●	7.2	16.0	21.1	60	8	1
20730S-2D	●	7.3	16.0	21.1	60	8	1
GSX 20740S-2D	●	7.4	16.0	21.1	60	8	1
20750S-2D	●	7.5	16.0	21.1	60	8	1
20760S-2D	●	7.6	16.0	21.1	60	8	1
20770S-2D	●	7.7	16.0	21.1	60	8	1
20780S-2D	●	7.8	16.0	21.1	60	8	1
GSX 20790S-2D	●	7.9	16.0	21.1	60	8	1
20800S-2D	●	8.0	19.0	—	60	8	2
20810S-2D	●	8.1	19.0	24.1	60	10	1
20820S-2D	●	8.2	19.0	24.1	60	10	1
20830S-2D	●	8.3	19.0	24.1	60	10	1
GSX 20840S-2D	●	8.4	19.0	24.1	60	10	1
20850S-2D	●	8.5	19.0	24.1	70	10	1
20860S-2D	●	8.6	19.0	24.1	70	10	1
20870S-2D	●	8.7	19.0	24.1	70	10	1
20880S-2D	●	8.8	19.0	24.1	70	10	1

Grade: ACF20

Endmills

I

Square

Radius

Ballnose

Multi-Purpose

General-Purpose

High Efficiency

Hardened Steel

Roughing

Non-Ferrous Metal

CFRP

Coated

Uncoated

GSX 20000S-2D type

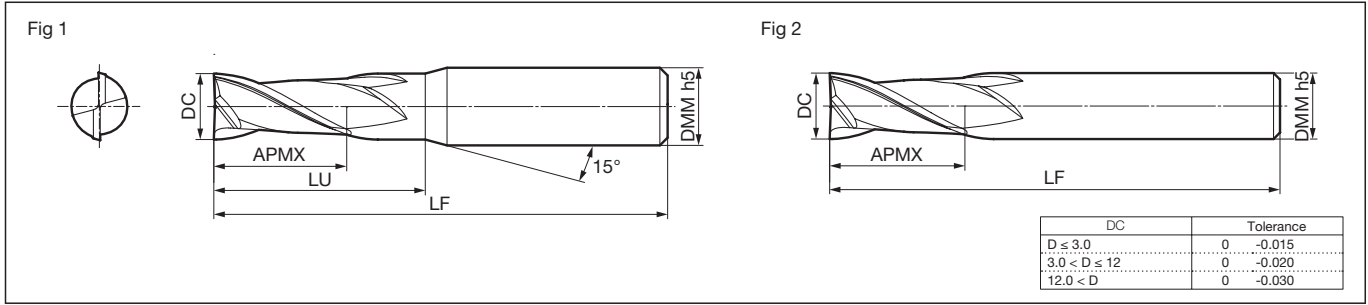
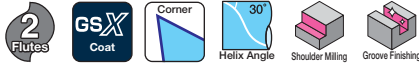

Body (Diameter ø8.9 to 25.0mm)

Dimensions (mm)

Cat. No.	Stock	Dia. DC	Cutting Edge Length APMX	Neck Length LU	Overall Length LF	Shank Dia. DMM	Fig
GSX 20890S-2D	●	8.9	19.0	24.1	70	10	1
20900S-2D	●	9.0	19.0	24.1	70	10	1
20910S-2D	●	9.1	19.0	24.1	70	10	1
20920S-2D	●	9.2	19.0	24.1	70	10	1
20930S-2D	●	9.3	19.0	24.1	70	10	1
GSX 20940S-2D	●	9.4	19.0	24.1	70	10	1
20950S-2D	●	9.5	20.0	25.1	70	10	1
20960S-2D	●	9.6	20.0	25.1	70	10	1
20970S-2D	●	9.7	20.0	25.1	70	10	1
20980S-2D	●	9.8	20.0	25.1	70	10	1
GSX 20990S-2D	●	9.9	20.0	25.1	70	10	1
21000S-2D	●	10.0	22.0	—	70	10	2
21050S-2D	●	10.5	22.0	24.5	75	12	1
21100S-2D	●	11.0	22.0	24.5	75	12	1
21150S-2D	●	11.5	23.0	25.5	75	12	1
GSX 21200S-2D	●	12.0	26.0	—	75	12	2
21250S-2D	●	12.5	26.0	29.5	75	16	1
21300S-2D	●	13.0	26.0	29.5	90	16	1
21400S-2D	●	14.0	28.0	31.5	90	16	1
21500S-2D	●	15.0	30.0	33.5	90	16	1
GSX 21600S-2D	●	16.0	32.0	—	90	16	2
21700S-2D	●	17.0	35.0	39.5	100	20	1
21800S-2D	●	18.0	40.0	44.5	100	20	1
21900S-2D	●	19.0	40.0	44.5	100	20	1
22000S-2D	●	20.0	40.0	—	100	20	2
GSX 22100S-2D	●	21.0	42.0	47.0	110	25	1
22200S-2D	●	22.0	44.0	49.0	110	25	1
22300S-2D	●	23.0	46.0	51.0	120	25	1
22400S-2D	●	24.0	48.0	53.0	120	25	1
22500S-2D	●	25.0	50.0	—	120	25	2

Grade: ACF20

Identification Code

GSX 2 0150 S - 2D - S3

Series Code No. of Flutes Dia. Corner Style S: Sharp Edge Cutting Edge Length Shank Dia.

Endmills

I

Square

Radius

Ballnose

Multi-Purpose

General-Purpose

High Efficiency

Hardened Steel

Roughing

Non-Ferrous Metal

CFRP

Coated

Uncoated

GSX 20000S-2D type

Recommended Cutting Conditions

1. For stable machining performance use rigid, high-precision machines and holders.
2. Use air blow when dry machining.
3. Use wet machining for stainless steel, heat-resistant alloy, and titanium alloy applications.
4. If chatter is a problem, reduce the spindle speed and feed rate indicated in the table below by the same ratio, or reduce the depth of cut.
5. This series is not recommended for groove milling.
6. If the machine cannot achieve the recommended spindle speed, please use the maximum spindle speed available.

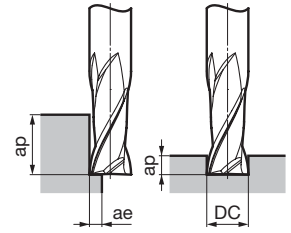

Side Milling

Work Material Cutting Conditions	Structural Steel SS		Carbon Steel SC (150 to 250HB)		Cast Iron FC		Alloy Steel SCM (25 to 35HRC)		Tempered Steel, Hardened Steel NAK, HPM (35 to 45HRC)		Hardened Steel (45 to 55HRC)		Stainless Steel SUS304,SUS316		Heat-Resistant Alloy Titanium Alloy	
	Spindle Speed (min ⁻¹)	Feed Rate (mm/min)	Spindle Speed (min ⁻¹)	Feed Rate (mm/min)	Spindle Speed (min ⁻¹)	Feed Rate (mm/min)	Spindle Speed (min ⁻¹)	Feed Rate (mm/min)	Spindle Speed (min ⁻¹)	Feed Rate (mm/min)	Spindle Speed (min ⁻¹)	Feed Rate (mm/min)	Spindle Speed (min ⁻¹)	Feed Rate (mm/min)	Spindle Speed (min ⁻¹)	Feed Rate (mm/min)
DC (mm)																
1.0	16,600	180	16,600	180	16,600	180	15,500	130	10,500	70	7,500	45	9,400	50	7,500	35
2.0	9,500	250	9,500	250	9,500	250	9,000	200	6,200	100	4,500	60	5,400	70	4,500	50
4.0	5,400	330	5,400	330	5,400	330	5,000	250	3,400	120	2,500	75	3,000	90	2,500	65
6.0	4,000	400	4,000	400	4,000	400	3,700	300	2,550	150	1,900	100	2,300	110	1,900	80
8.0	3,000	400	3,000	400	3,000	400	2,800	300	1,900	150	1,400	100	1,700	110	1,400	80
10.0	2,400	400	2,400	400	2,400	400	2,200	300	1,500	150	1,100	100	1,300	110	1,100	80
12.0	2,000	400	2,000	400	2,000	400	1,850	300	1,300	150	950	100	1,100	110	950	80
16.0	1,500	330	1,500	330	1,500	330	1,400	250	950	120	700	75	850	85	700	60
20.0	1,200	280	1,200	280	1,200	280	1,100	220	750	110	550	65	650	75	550	55
25.0	960	220	960	220	960	220	880	170	600	85	440	50	520	60	440	45
Standard Depth of Cut	ap	2.0DC										0.01DC				
ae	0.02DC															

Groove Finishing

Work Material Cutting Conditions	Structural Steel SS		Carbon Steel SC (150 to 250HB)		Cast Iron FC		Alloy Steel SCM (25 to 35HRC)		Tempered Steel, Hardened Steel NAK, HPM (35 to 45HRC)		Hardened Steel (45 to 55HRC)		Stainless Steel SUS304,SUS316		Heat-Resistant Alloy Titanium Alloy	
	Spindle Speed (min ⁻¹)	Feed Rate (mm/min)	Spindle Speed (min ⁻¹)	Feed Rate (mm/min)	Spindle Speed (min ⁻¹)	Feed Rate (mm/min)	Spindle Speed (min ⁻¹)	Feed Rate (mm/min)	Spindle Speed (min ⁻¹)	Feed Rate (mm/min)	Spindle Speed (min ⁻¹)	Feed Rate (mm/min)	Spindle Speed (min ⁻¹)	Feed Rate (mm/min)	Spindle Speed (min ⁻¹)	Feed Rate (mm/min)
DC (mm)																
1.0	16,600	180	16,600	180	16,600	180	15,500	130	10,500	70	7,500	45	9,400	50	7,500	35
2.0	9,500	250	9,500	250	9,500	250	9,000	200	6,200	100	4,500	60	5,400	70	4,500	50
4.0	5,400	330	5,400	330	5,400	330	5,000	250	3,400	120	2,500	75	3,000	90	2,500	65
6.0	4,000	400	4,000	400	4,000	400	3,700	300	2,550	150	1,900	100	2,300	110	1,900	80
8.0	3,000	400	3,000	400	3,000	400	2,800	300	1,900	150	1,400	100	1,700	110	1,400	80
10.0	2,400	400	2,400	400	2,400	400	2,200	300	1,500	150	1,100	100	1,300	110	1,100	80
12.0	2,000	400	2,000	400	2,000	400	1,850	300	1,300	150	950	100	1,100	110	950	80
16.0	1,500	330	1,500	330	1,500	330	1,400	250	950	120	700	75	850	85	700	60
20.0	1,200	280	1,200	280	1,200	280	1,100	220	750	110	550	65	650	75	550	55
25.0	960	220	960	220	960	220	880	170	600	85	440	50	520	60	440	45
Standard Depth of Cut	ap	1.5DC														
ae	Below 0.02DC															

Endmills
I
Square
Radius
Ballnose
Multi-Purpose
General-Purpose
High Efficiency
Hardened Steel
Roughing
Non-Ferrous Metal
CFRP
Coated
Uncoated

GSX 20000C-2D type

- General Steel
- Carbon Steel
- Alloy Steel
- Pre-hardened Steel
- Tempered Steel / Die Steel
- Hardened Steel 45 to 55HRC
- Hardened Steel 55 to 60HRC
- Stainless Steel
- Ti Alloy / Heat Resistant Alloy
- Cast Iron

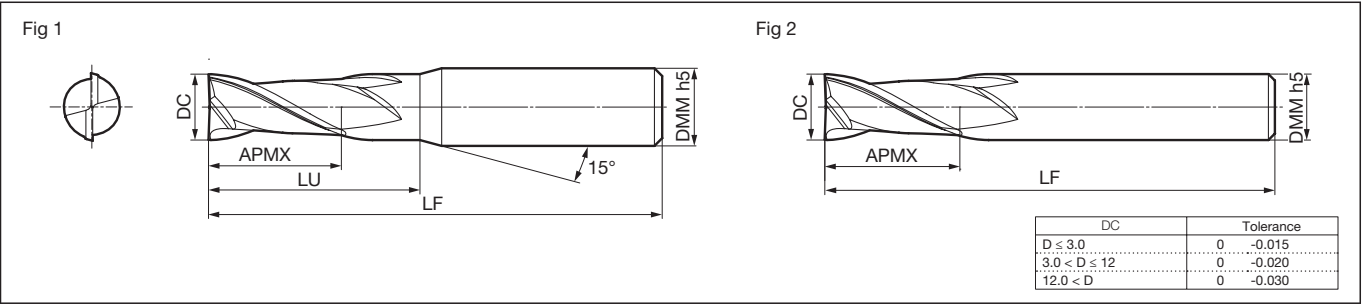

Body Dimensions (mm)

Cat. No.	Stock	Dia. DC	Cutting Edge Length APMX	Neck Length LU	Overall Length LF	Shank Dia. DMM	Fig
GSX 20050C-2D	●	0.5	1.0	1.4	40	4	1
20100C-2D	●	1.0	2.0	3.0	40	4	1
20150C-2D	●	1.5	3.0	4.0	40	4	1
20200C-2D	●	2.0	4.0	5.0	40	4	1
20250C-2D	●	2.5	5.0	6.0	40	4	1
GSX 20300C-2D	●	3.0	6.0	7.5	45	6	1
20350C-2D	●	3.5	7.0	8.5	45	6	1
20400C-2D	●	4.0	8.0	9.5	45	6	1
20450C-2D	●	4.5	9.0	10.5	50	6	1
20500C-2D	●	5.0	10.0	12.0	50	6	1
GSX 20550C-2D	●	5.5	11.0	13.0	50	6	1
20600C-2D	●	6.0	12.0	—	50	6	2
20650C-2D	●	6.5	13.0	15.0	60	8	1
20700C-2D	●	7.0	14.0	16.0	60	8	1
20750C-2D	●	7.5	15.0	17.0	60	8	1
GSX 20800C-2D	●	8.0	16.0	—	60	8	2
20850C-2D	●	8.5	17.0	19.0	70	10	1
20900C-2D	●	9.0	18.0	20.0	70	10	1
20950C-2D	●	9.5	19.0	21.0	70	10	1
21000C-2D	●	10.0	20.0	—	70	10	2
GSX 21050C-2D	●	10.5	21.0	23.5	75	12	1
21100C-2D	●	11.0	22.0	24.5	75	12	1
21150C-2D	●	11.5	23.0	25.5	75	12	1
21200C-2D	●	12.0	24.0	—	75	12	2
21300C-2D	●	13.0	26.0	29.5	90	16	1
GSX 21400C-2D	●	14.0	28.0	31.5	90	16	1
21500C-2D	●	15.0	30.0	33.5	90	16	1
21600C-2D	●	16.0	32.0	—	90	16	2
21700C-2D	●	17.0	34.0	38.5	100	20	1
21800C-2D	●	18.0	36.0	40.5	100	20	1
GSX 21900C-2D	●	19.0	38.0	42.5	100	20	1
22000C-2D	●	20.0	40.0	—	100	20	2
22500C-2D	●	25.0	50.0	—	120	25	2

Grade: ACF20

Identification Code

GSX 2 0050 C - 2D

Series Code No. of Flutes Dia. Corner Style Cutting Edge Length
 C: Gash Land

Endmills

I

Square

Radius

Ballnose

Multi-Purpose

General-Purpose

High Efficiency

Hardened Steel

Roughing

Non-Ferrous Metal

CFRP

Coated

Uncoated

GSX 20000C-2D type

Recommended Cutting Conditions

1. For stable machining performance use rigid, high-precision machines and holders.
2. Use air blow when dry machining.
3. Use wet machining for stainless steel, heat-resistant alloy, and titanium alloy applications.
4. If chatter is a problem, reduce the spindle speed and feed rate indicated in the table below by the same ratio, or reduce the depth of cut.
5. If the machine cannot achieve the recommended spindle speed, please use the maximum spindle speed available.

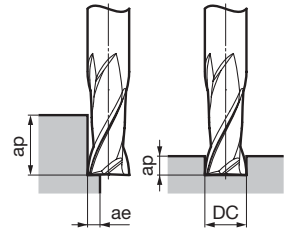

Side Milling

Work Material Cutting Conditions	Structural Steel SS		Carbon Steel SC (150 to 250HB)		Cast Iron FC		Alloy Steel SCM (25 to 35HRC)		Tempered Steel, Hardened Steel NAK, HPM (35 to 45HRC)		Hardened Steel (45 to 55HRC)		Stainless Steel SUS304,SUS316		Heat-Resistant Alloy Titanium Alloy	
	Spindle Speed (min ⁻¹)	Feed Rate (mm/min)	Spindle Speed (min ⁻¹)	Feed Rate (mm/min)	Spindle Speed (min ⁻¹)	Feed Rate (mm/min)	Spindle Speed (min ⁻¹)	Feed Rate (mm/min)	Spindle Speed (min ⁻¹)	Feed Rate (mm/min)	Spindle Speed (min ⁻¹)	Feed Rate (mm/min)	Spindle Speed (min ⁻¹)	Feed Rate (mm/min)	Spindle Speed (min ⁻¹)	Feed Rate (mm/min)
Dc (mm)																
1.0	19,600	250	19,600	250	19,600	250	18,300	180	12,700	100	9,000	60	11,000	70	9,000	50
2.0	11,200	340	11,200	340	11,200	340	10,500	240	7,300	130	5,300	80	6,400	90	5,300	70
4.0	6,400	460	6,400	460	6,400	460	6,000	320	4,200	180	3,000	110	3,600	120	3,000	90
6.0	4,600	560	4,600	560	4,600	560	4,300	400	3,000	210	2,200	130	2,700	140	2,200	100
8.0	3,400	560	3,400	560	3,400	560	3,200	400	2,200	210	1,600	130	2,000	140	1,600	100
10.0	2,800	560	2,800	560	2,800	560	2,600	400	1,800	210	1,300	130	1,600	140	1,300	100
12.0	2,300	560	2,300	560	2,300	560	2,200	400	1,500	210	1,100	130	1,300	140	1,100	100
16.0	1,700	450	1,700	450	1,700	450	1,600	320	1,100	180	800	100	1,000	110	800	85
20.0	1,350	380	1,350	380	1,350	380	1,300	280	900	160	650	90	800	100	650	75
25.0	1,000	300	1,000	300	1,000	300	1,000	220	700	120	500	70	640	80	500	60
Standard Depth of Cut	ap	1.5DC										1.0DC				
	ae	0.05DC										0.02DC				

Groove Milling

Work Material Cutting Conditions	Structural Steel SS		Carbon Steel SC (150 to 250HB)		Cast Iron FC		Alloy Steel SCM (25 to 35HRC)		Tempered Steel, Hardened Steel NAK, HPM (35 to 45HRC)		Hardened Steel (45 to 55HRC)		Stainless Steel SUS304,SUS316		Heat-Resistant Alloy Titanium Alloy	
	Spindle Speed (min ⁻¹)	Feed Rate (mm/min)	Spindle Speed (min ⁻¹)	Feed Rate (mm/min)	Spindle Speed (min ⁻¹)	Feed Rate (mm/min)	Spindle Speed (min ⁻¹)	Feed Rate (mm/min)	Spindle Speed (min ⁻¹)	Feed Rate (mm/min)	Spindle Speed (min ⁻¹)	Feed Rate (mm/min)	Spindle Speed (min ⁻¹)	Feed Rate (mm/min)	Spindle Speed (min ⁻¹)	Feed Rate (mm/min)
DC(mm)																
1.0	19,600	200	19,600	250	19,600	250	18,300	180	12,700	100	9,000	60	11,000	50	4,500	20
2.0	11,200	270	11,200	340	11,200	340	10,500	240	7,300	130	5,300	80	6,400	65	2,650	25
4.0	6,400	370	6,400	460	6,400	460	6,000	320	4,200	180	3,000	110	3,600	80	1,500	35
6.0	4,600	450	4,600	560	4,600	560	4,300	400	3,000	210	2,200	130	2,700	100	1,100	40
8.0	3,400	450	3,400	560	3,400	560	3,200	400	2,200	210	1,600	130	2,000	100	800	40
10.0	2,800	450	2,800	560	2,800	560	2,600	400	1,800	210	1,300	130	1,600	100	650	40
12.0	2,300	450	2,300	560	2,300	560	2,200	400	1,500	210	1,100	130	1,300	100	500	40
16.0	1,700	360	1,700	450	1,700	450	1,600	320	1,100	180	800	100	1,000	80	400	35
20.0	1,350	300	1,350	380	1,350	380	1,300	280	900	160	650	90	800	70	320	30
25.0	1,000	240	1,000	300	1,000	300	1,000	220	700	120	500	70	640	55	250	25
Standard Depth of Cut	ap	0.2DC		0.5DC				0.2DC		0.05DC		0.2DC				

Endmills
 I
 Square
 Radius
 Ballnose
 Multi-Purpose
 General-Purpose
 High Efficiency
 Hardened Steel
 Roughing
 Non-Ferrous Metal
 CFRP
 Coated
 Uncoated

GSX 20000S-3D type

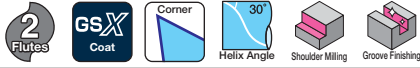

Fig 1

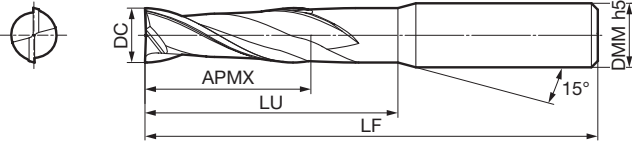
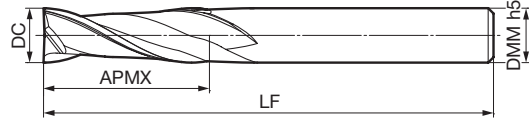

Fig 2



DC	Tolerance
D ≤ 3.0	0 -0.015
3.0 < D ≤ 12	0 -0.020
12.0 < D	0 -0.030

Body

Dimensions (mm)

Cat. No.	Stock	Dia. DC	Cutting Edge Length APMX	Neck Length LU	Overall Length LF	Shank Dia. DMM	Fig
GSX 20050S-3D	●	0.5	1.5	1.9	40	4	1
20100S-3D	●	1.0	3.0	4.0	40	4	1
20150S-3D	●	1.5	4.5	5.5	40	4	1
20200S-3D	●	2.0	6.0	7.0	40	4	1
20250S-3D	●	2.5	7.5	8.5	40	4	1
GSX 20260S-3D	●	2.6	8.0	9.5	50	4	1
20270S-3D	●	2.7	8.5	10.0	50	4	1
20280S-3D	●	2.8	9.0	10.5	50	4	1
20290S-3D	●	2.9	9.0	10.5	50	4	1
20300S-3D	●	3.0	9.0	10.5	50	6	1
GSX 20350S-3D	●	3.5	12.0	13.5	50	6	1
20400S-3D	●	4.0	12.0	13.5	50	6	1
20450S-3D	●	4.5	15.0	16.5	50	6	1
20500S-3D	●	5.0	15.0	17.0	50	6	1
20550S-3D	●	5.5	18.0	20.0	50	6	1
GSX 20600S-3D	●	6.0	18.0	—	50	6	2
20650S-3D	●	6.5	20.0	22.0	70	8	1
20700S-3D	●	7.0	21.0	23.0	70	8	1
20750S-3D	●	7.5	23.0	25.0	70	8	1
20800S-3D	●	8.0	24.0	—	70	8	2
GSX 20850S-3D	●	8.5	26.0	28.0	75	10	1
20900S-3D	●	9.0	27.0	29.0	75	10	1
20950S-3D	●	9.5	29.0	31.0	75	10	1
21000S-3D	●	10.0	30.0	—	90	10	2
21050S-3D	●	10.5	32.0	34.5	90	12	1
GSX 21100S-3D	●	11.0	33.0	35.5	90	12	1
21150S-3D	●	11.5	35.0	37.5	90	12	1
21200S-3D	●	12.0	36.0	—	90	12	2
21300S-3D	●	13.0	39.0	42.5	100	16	1
21400S-3D	●	14.0	42.0	45.5	110	16	1
GSX 21500S-3D	●	15.0	45.0	48.5	110	16	1
21600S-3D	●	16.0	48.0	—	110	16	2
21700S-3D	●	17.0	51.0	55.5	110	20	1
21800S-3D	●	18.0	54.0	58.5	120	20	1
21900S-3D	●	19.0	57.0	61.5	120	20	1
GSX 22000S-3D	●	20.0	60.0	—	120	20	2
22400S-3D	●	24.0	72.0	77.0	130	25	1
22500S-3D	●	25.0	75.0	—	130	25	2

Grade: ACF20

Identification Code

GSX 2 0050 S - 3D

Series Code No. of Flutes Dia. Corner Style Cutting Edge Length
 S: Sharp Edge

Endmills

Square

Radius

Ballnose

Multi-Purpose

General-Purpose

High Efficiency

Hardened Steel

Roughing

Non-Ferrous Metal

CFRP

Coated

Uncoated

GSX 2000S-3D type

Recommended Cutting Conditions

1. For stable machining performance use rigid, high-precision machines and holders.
2. Use air blow when dry machining.
3. Use wet machining for stainless steel, heat-resistant alloy, and titanium alloy applications.
4. If chatter is a problem, reduce the spindle speed and feed rate indicated in the table below by the same ratio, or reduce the depth of cut.
5. This series is not recommended for groove milling.
6. If the machine cannot achieve the recommended spindle speed, please use the maximum spindle speed available.

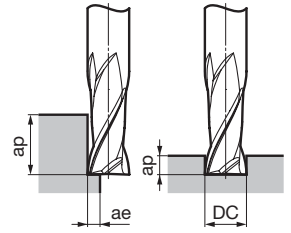

Side Milling

Work Material Cutting Conditions	Structural Steel SS		Carbon Steel SC (150 to 250HB)		Cast Iron FC		Alloy Steel SCM (25 to 35HRC)		Tempered Steel, Hardened Steel NAK, HPM (35 to 45HRC)		Hardened Steel (45 to 55HRC)		Stainless Steel SUS304,SUS316		Heat-Resistant Alloy Titanium Alloy		
	DC (mm)	Spindle Speed (min ⁻¹)	Feed Rate (mm/min)	Spindle Speed (min ⁻¹)	Feed Rate (mm/min)	Spindle Speed (min ⁻¹)	Feed Rate (mm/min)	Spindle Speed (min ⁻¹)	Feed Rate (mm/min)	Spindle Speed (min ⁻¹)	Feed Rate (mm/min)	Spindle Speed (min ⁻¹)	Feed Rate (mm/min)	Spindle Speed (min ⁻¹)	Feed Rate (mm/min)	Spindle Speed (min ⁻¹)	Feed Rate (mm/min)
1.0	14,000	140	14,000	140	14,000	140	13,200	100	8,900	50	6,300	30	8,000	35	6,300	25	
2.0	8,100	180	8,100	180	8,100	180	7,600	150	5,300	90	3,700	45	4,400	50	3,800	40	
4.0	4,400	240	4,400	240	4,400	240	4,000	150	2,900	110	1,900	55	2,200	65	1,900	50	
6.0	2,900	260	2,900	260	2,900	260	2,700	180	2,100	130	1,200	65	1,400	75	1,200	60	
8.0	2,200	230	2,200	230	2,200	230	2,000	180	1,600	130	900	65	1,100	75	900	60	
10.0	1,800	220	1,800	220	1,800	220	1,600	170	1,300	130	750	65	850	75	750	60	
12.0	1,500	200	1,500	200	1,500	200	1,300	170	1,000	130	630	65	700	75	600	60	
16.0	1,100	170	1,100	170	1,100	170	1,000	150	800	110	450	55	550	65	450	50	
20.0	850	160	850	160	850	160	800	130	600	100	350	50	400	55	350	45	
25.0	680	130	680	130	680	130	640	100	480	80	280	40	320	45	280	35	
Standard Depth of Cut	ap	2.5DC								2.0DC							
	ae	Below a3: 0.02DC Above a3: 0.05DC								0.01DC							

Groove Finishing

Work Material Cutting Conditions	Structural Steel SS		Carbon Steel SC (150 to 250HB)		Cast Iron FC		Alloy Steel SCM (25 to 35HRC)		Tempered Steel, Hardened Steel NAK, HPM (35 to 45HRC)		Hardened Steel (45 to 55HRC)		Stainless Steel SUS304,SUS316		Heat-Resistant Alloy Titanium Alloy	
	DC (mm)	Spindle Speed (min ⁻¹)	Feed Rate (mm/min)	Spindle Speed (min ⁻¹)	Feed Rate (mm/min)	Spindle Speed (min ⁻¹)	Feed Rate (mm/min)	Spindle Speed (min ⁻¹)	Feed Rate (mm/min)	Spindle Speed (min ⁻¹)	Feed Rate (mm/min)	Spindle Speed (min ⁻¹)	Feed Rate (mm/min)	Spindle Speed (min ⁻¹)	Feed Rate (mm/min)	Spindle Speed (min ⁻¹)
1.0	14,000	140	14,000	140	14,000	140	13,200	100	8,900	50	6,300	30	8,000	35	6,300	25
2.0	8,100	180	8,100	180	8,100	180	7,600	150	5,300	90	3,700	45	4,400	50	3,800	40
4.0	4,400	240	4,400	240	4,400	240	4,000	150	2,900	110	1,900	55	2,200	65	1,900	50
6.0	2,900	260	2,900	260	2,900	260	2,700	180	2,100	130	1,200	65	1,400	75	1,200	60
8.0	2,200	230	2,200	230	2,200	230	2,000	180	1,600	130	900	65	1,100	75	900	60
10.0	1,800	220	1,800	220	1,800	220	1,600	170	1,300	130	750	65	850	75	750	60
12.0	1,500	200	1,500	200	1,500	200	1,300	170	1,000	130	630	65	700	75	600	60
16.0	1,100	170	1,100	170	1,100	170	1,000	150	800	110	450	55	550	65	450	50
20.0	850	160	850	160	850	160	800	130	600	100	350	50	400	55	350	45
25.0	680	130	680	130	680	130	640	100	480	80	280	40	320	45	280	35
Standard Depth of Cut	ap	1.5DC														
	ae	Below 0.02DC														

Endmills

I

Square

Radius

Ballnose

Multi-Purpose

General-Purpose

High Efficiency

Hardened Steel

Roughing

Non-Ferrous Metal

CFRP

Coated

Uncoated

GSX 20000C-3D type



Endmills

I

Square

Radius

Ballnose

Multi-Purpose

General-Purpose

High Efficiency

Hardened Steel

Roughing

Non-Ferrous Metal

CFRP

Coated

Uncoated

Fig 1

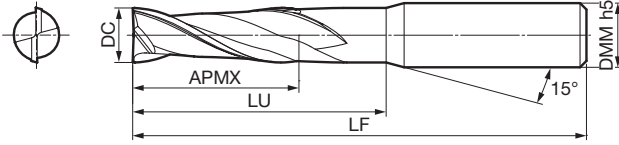
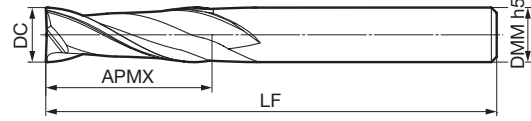

Fig 2



DC	Tolerance
D ≤ 3.0	0 -0.015
3.0 < D ≤ 12	0 -0.020
12.0 < D	0 -0.030

Body

Dimensions (mm)

Cat. No.	Stock	Dia. DC	Cutting Edge Length APMX	Neck Length LU	Overall Length LF	Shank Dia. DMM	Fig
GSX 20050C-3D	●	0.5	1.5	1.9	40	4	1
20100C-3D	●	1.0	3.0	4.0	40	4	1
20150C-3D	●	1.5	4.5	5.5	40	4	1
20200C-3D	●	2.0	6.0	7.0	40	4	1
20250C-3D	●	2.5	7.5	8.5	40	4	1
GSX 20300C-3D	●	3.0	9.0	10.5	50	6	1
20350C-3D	●	3.5	11.0	12.5	50	6	1
20400C-3D	●	4.0	12.0	13.5	50	6	1
20450C-3D	●	4.5	14.0	15.5	50	6	1
20500C-3D	●	5.0	15.0	17.0	50	6	1
GSX 20550C-3D	●	5.5	17.0	19.0	50	6	1
20600C-3D	●	6.0	18.0	—	50	6	2
20650C-3D	●	6.5	20.0	22.0	70	8	1
20700C-3D	●	7.0	21.0	23.0	70	8	1
20750C-3D	●	7.5	23.0	25.0	70	8	1
GSX 20800C-3D	●	8.0	24.0	—	70	8	2
20850C-3D	●	8.5	26.0	28.0	75	10	1
20900C-3D	●	9.0	27.0	29.0	75	10	1
20950C-3D	●	9.5	29.0	31.0	75	10	1
21000C-3D	●	10.0	30.0	—	90	10	2
GSX 21050C-3D	●	10.5	32.0	34.5	90	12	1
21100C-3D	●	11.0	33.0	35.5	90	12	1
21150C-3D	●	11.5	35.0	37.5	90	12	1
21200C-3D	●	12.0	36.0	—	90	12	2
21300C-3D	●	13.0	39.0	42.5	100	16	1
GSX 21400C-3D	●	14.0	42.0	45.5	110	16	1
21500C-3D	●	15.0	45.0	48.5	110	16	1
21600C-3D	●	16.0	48.0	—	110	16	2
21700C-3D	●	17.0	51.0	55.5	110	20	1
21800C-3D	●	18.0	54.0	58.5	120	20	1
GSX 21900C-3D	●	19.0	57.0	61.5	120	20	1
22000C-3D	●	20.0	60.0	—	120	20	2
22500C-3D	●	25.0	75.0	—	130	25	2

Grade: ACF20

Identification Code

GSX 2 0100 C - 3D

Series Code No. of Flutes Dia. Corner Style C: Gash Land Cutting Edge Length

GSX 20000C-3D type

Recommended Cutting Conditions

1. For stable machining performance use rigid, high-precision machines and holders.
2. Use air blow when dry machining.
3. Use wet machining for stainless steel, heat-resistant alloy, and titanium alloy applications.
4. In some cases, chatter may occur in early stages of milling but will cease after 2m of cutting.
5. If chatter is a problem, reduce the spindle speed and feed rate indicated in the table below by the same ratio, or reduce the depth of cut.
6. If the machine cannot achieve the recommended spindle speed, please use the maximum spindle speed available.

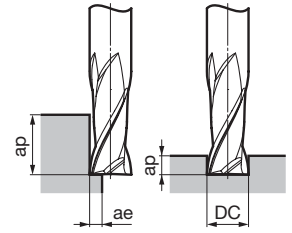

Side Milling

Work Material Cutting Conditions	Structural Steel SS		Carbon Steel SC (150 to 250HB)		Cast Iron FC		Alloy Steel SCM (25 to 35HRC)		Tempered Steel, Hardened Steel NAK, HPM (35 to 45HRC)		Hardened Steel (45 to 55HRC)		Stainless Steel SUS304,SUS316		Heat-Resistant Alloy Titanium Alloy	
	Spindle Speed (min ⁻¹)	Feed Rate (mm/min)	Spindle Speed (min ⁻¹)	Feed Rate (mm/min)	Spindle Speed (min ⁻¹)	Feed Rate (mm/min)	Spindle Speed (min ⁻¹)	Feed Rate (mm/min)	Spindle Speed (min ⁻¹)	Feed Rate (mm/min)	Spindle Speed (min ⁻¹)	Feed Rate (mm/min)	Spindle Speed (min ⁻¹)	Feed Rate (mm/min)	Spindle Speed (min ⁻¹)	Feed Rate (mm/min)
DC (mm)																
1.0	16,600	190	16,600	190	16,600	190	15,500	140	10,500	70	7,500	45	9,400	50	7,500	35
2.0	9,500	250	9,500	250	9,500	250	9,000	200	6,200	120	4,500	60	5,200	70	4,500	50
4.0	5,200	330	5,200	330	5,200	330	4,800	200	3,400	150	2,250	75	2,600	90	2,250	65
6.0	3,500	360	3,500	360	3,500	360	3,200	250	2,550	170	1,500	90	1,700	100	1,500	80
8.0	2,600	320	2,600	320	2,600	320	2,400	240	1,900	170	1,100	90	1,300	100	1,100	80
10.0	2,100	300	2,100	300	2,100	300	1,900	230	1,500	170	900	90	1,000	100	900	80
12.0	1,750	280	1,750	280	1,750	280	1,600	230	1,250	170	750	90	850	100	750	80
16.0	1,300	240	1,300	240	1,300	240	1,200	200	950	150	550	75	650	85	550	65
20.0	1,050	220	1,050	220	1,050	220	950	180	750	140	450	70	500	75	450	60
25.0	840	180	840	180	840	180	760	140	600	110	360	55	400	60	360	45
Standard Depth of Cut	2.5DC								2.0DC							
	Below ø3: 0.05DC Above ø3: 0.1DC								0.02DC							

Groove Milling

Work Material Cutting Conditions	Structural Steel SS		Carbon Steel SC (150 to 250HB)		Cast Iron FC		Alloy Steel SCM (25 to 35HRC)		Tempered Steel, Hardened Steel NAK, HPM (35 to 45HRC)		Hardened Steel (45 to 55HRC)		Stainless Steel SUS304,SUS316		Heat-Resistant Alloy Titanium Alloy	
	Spindle Speed (min ⁻¹)	Feed Rate (mm/min)	Spindle Speed (min ⁻¹)	Feed Rate (mm/min)	Spindle Speed (min ⁻¹)	Feed Rate (mm/min)	Spindle Speed (min ⁻¹)	Feed Rate (mm/min)	Spindle Speed (min ⁻¹)	Feed Rate (mm/min)	Spindle Speed (min ⁻¹)	Feed Rate (mm/min)	Spindle Speed (min ⁻¹)	Feed Rate (mm/min)	Spindle Speed (min ⁻¹)	Feed Rate (mm/min)
DC (mm)																
1.0	16,600	70	16,600	80	16,600	80	15,500	50	10,500	50	7,500	35	9,400	30	3,750	10
2.0	9,500	80	9,500	100	9,500	100	9,000	90	6,200	60	4,500	45	5,200	40	2,250	15
4.0	5,200	120	5,200	150	5,200	150	4,800	120	3,400	80	2,200	50	2,600	50	1,250	20
6.0	3,500	140	3,500	170	3,500	170	3,200	130	2,550	100	1,500	50	1,700	60	950	25
8.0	2,600	140	2,600	160	2,600	160	2,400	130	1,900	100	1,100	50	1,300	60	700	25
10.0	2,100	130	2,100	150	2,100	150	1,900	120	1,500	90	900	50	1,000	60	550	25
12.0	1,750	130	1,750	150	1,750	150	1,600	120	1,250	90	750	50	850	60	450	25
16.0	1,300	110	1,300	130	1,300	130	1,200	110	950	80	550	45	650	50	350	20
20.0	1,050	100	1,050	120	1,050	120	950	100	750	70	450	40	500	40	280	15
25.0	840	80	840	96	840	96	760	80	600	56	360	32	400	32	224	12
Standard Depth of Cut	0.1DC		0.2DC						0.05DC		0.1DC					

Endmills

I

Square

Radius

Ballnose

Multi-Purpose

General-Purpose

High Efficiency

Hardened Steel

Roughing

Non-Ferrous Metal

CFRP

Coated

Uncoated

GSX 20000S-4D type

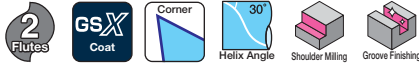

Fig 1

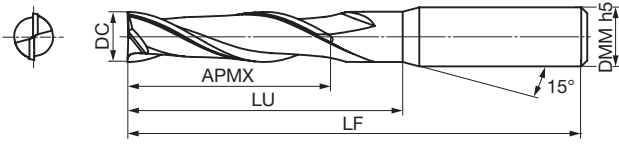
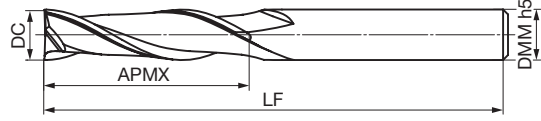

Fig 2



DC	Tolerance
D ≤ 3.0	0 -0.015
3.0 < D ≤ 12	0 -0.020
12.0 < D	0 -0.030

Body

Dimensions (mm)

Cat. No.	Stock	Dia. DC	Cutting Edge Length APMX	Neck Length LU	Overall Length LF	Shank Dia. DMM	Fig
GSX 20050S-4D	●	0.5	2.0	2.4	40	4	1
20100S-4D	●	1.0	5.0	6.0	40	4	1
20150S-4D	●	1.5	7.0	8.0	40	4	1
20200S-4D	●	2.0	9.0	10.0	40	4	1
20250S-4D	●	2.5	12.0	13.0	50	4	1
GSX 20300S-4D	●	3.0	12.0	13.5	50	6	1
20350S-4D	●	3.5	14.0	15.5	50	6	1
20400S-4D	●	4.0	16.0	17.5	50	6	1
20450S-4D	●	4.5	18.0	19.5	60	6	1
20500S-4D	●	5.0	20.0	22.0	60	6	1
GSX 20550S-4D	●	5.5	22.0	24.0	60	6	1
20600S-4D	●	6.0	24.0	—	60	6	2
20650S-4D	●	6.5	26.0	28.0	70	8	1
20700S-4D	●	7.0	28.0	30.0	80	8	1
20750S-4D	●	7.5	30.0	32.0	80	8	1
GSX 20800S-4D	●	8.0	32.0	—	80	8	2
20850S-4D	●	8.5	34.0	36.0	90	10	1
20900S-4D	●	9.0	36.0	38.0	90	10	1
20950S-4D	●	9.5	38.0	40.0	90	10	1
21000S-4D	●	10.0	40.0	—	90	10	2
GSX 21050S-4D	●	10.5	42.0	44.5	100	12	1
21100S-4D	●	11.0	44.0	46.5	100	12	1
21150S-4D	●	11.5	46.0	48.5	100	12	1
21200S-4D	●	12.0	48.0	—	100	12	2
21300S-4D	●	13.0	52.0	55.5	110	16	1
GSX 21400S-4D	●	14.0	56.0	59.5	110	16	1
21500S-4D	●	15.0	60.0	63.5	120	16	1
21600S-4D	●	16.0	64.0	—	120	16	2
21700S-4D	●	17.0	68.0	72.5	130	20	1
21800S-4D	●	18.0	72.0	76.5	130	20	1
GSX 21900S-4D	●	19.0	76.0	80.5	140	20	1
22000S-4D	●	20.0	80.0	—	140	20	2
22500S-4D	●	25.0	100.0	—	160	25	2

Grade: ACF20

Identification Code

GSX 2 0100 S - 4D

Series Code No. of Flutes Dia. Corner Style Cutting Edge Length
 S: Sharp Edge

Endmills
I

Square

Radius

Ballnose

Multi-Purpose

General-Purpose

High Efficiency

Hardened Steel

Roughing

Non-Ferrous Metal

CFRP

Coated

Uncoated

GSX 20000S-4D type

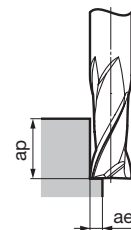

Recommended Cutting Conditions

1. For stable machining performance use rigid, high-precision machines and holders.
2. Use air blow when dry machining.
3. Use wet machining for stainless steel, heat-resistant alloy, and titanium alloy applications.
4. If chatter is a problem, reduce the spindle speed and feed rate indicated in the table below by the same ratio, or reduce the depth of cut.
5. This series is not recommended for groove milling.
6. If the machine cannot achieve the recommended spindle speed, please use the maximum spindle speed available.

Side Milling

Work Material Cutting Conditions	Structural Steel SS		Carbon Steel SC (150 to 250HB)		Cast Iron FC		Alloy Steel SCM (25 to 35HRC)		Tempered Steel, Hardened Steel NAK, HPM (35 to 45HRC)		Hardened Steel (45 to 55HRC)		Stainless Steel SUS304, SUS316		Heat-Resistant Alloy Titanium Alloy		
	DC (mm)	Spindle Speed (min ⁻¹)	Feed Rate (mm/min)	Spindle Speed (min ⁻¹)	Feed Rate (mm/min)	Spindle Speed (min ⁻¹)	Feed Rate (mm/min)	Spindle Speed (min ⁻¹)	Feed Rate (mm/min)	Spindle Speed (min ⁻¹)	Feed Rate (mm/min)	Spindle Speed (min ⁻¹)	Feed Rate (mm/min)	Spindle Speed (min ⁻¹)	Feed Rate (mm/min)	Spindle Speed (min ⁻¹)	Feed Rate (mm/min)
1.0	7,600	110	7,600	110	7,600	110	6,000	80	5,500	40	3,800	25	4,600	35	3,800	20	
2.0	3,850	150	3,850	150	3,850	150	2,950	100	2,750	60	1,900	30	2,300	40	1,950	30	
4.0	1,900	200	1,900	200	1,900	200	1,450	130	1,350	80	1,000	50	1,150	55	1,000	35	
6.0	1,250	250	1,250	250	1,250	250	970	140	860	90	640	60	740	60	640	40	
8.0	930	220	930	220	930	220	700	140	670	90	500	60	560	60	490	40	
10.0	770	210	770	210	770	210	190	130	560	95	380	60	460	60	380	40	
12.0	650	200	650	200	650	200	470	130	420	85	330	60	370	60	320	40	
16.0	450	170	450	170	450	170	370	120	340	80	250	45	280	50	250	35	
20.0	360	140	360	140	360	140	300	100	260	70	190	35	220	40	190	30	
25.0	190	120	190	120	190	120	230	80	200	55	150	30	170	30	150	25	
Standard	ap	2.5DC								2.0DC							
Depth of Cut	ae	Below ø3: 0.02DC				Above ø3: 0.05DC				0.01DC							

Endmills

I

Square

Radius

Ballnose

Multi-Purpose

General-Purpose

High Efficiency

Hardened Steel

Roughing

Non-Ferrous Metal

CFRP

Coated

Uncoated

GSX 20000C-4D type

- General Steel
- Carbon Steel
- Alloy Steel
- Pre-hardened Steel
- Tempered Steel / Die Steel
- Hardened Steel 45 to 55HRC
- Hardened Steel 55 to 60HRC
- Stainless Steel
- Ti Alloy Heat Resistant Alloy
- Cast Iron

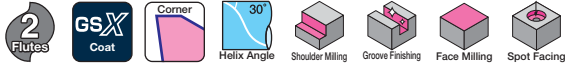

Fig 1

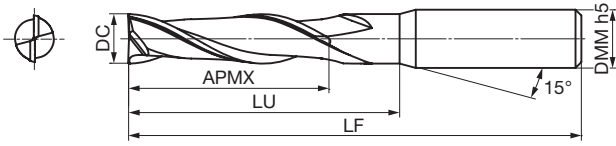
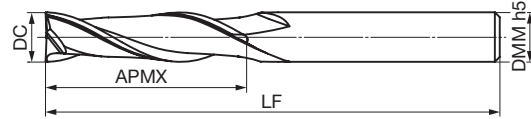

Fig 2



DC	Tolerance
D ≤ 3.0	0 -0.015
3.0 < D ≤ 12	0 -0.020
12.0 < D	0 -0.030

Body

Dimensions (mm)

Cat. No.	Stock	Dia. DC	Cutting Edge Length APMX	Neck Length LU	Overall Length LF	Shank Dia. DMM	Fig
GSX 20050C-4D	●	0.5	2.0	2.4	40	4	1
20100C-4D	●	1.0	4.0	5.0	40	4	1
20150C-4D	●	1.5	6.0	7.0	40	4	1
20200C-4D	●	2.0	8.0	9.0	40	4	1
20250C-4D	●	2.5	10.0	11.0	50	4	1
GSX 20300C-4D	●	3.0	12.0	13.5	50	6	1
20350C-4D	●	3.5	14.0	15.5	50	6	1
20400C-4D	●	4.0	16.0	17.5	50	6	1
20450C-4D	●	4.5	18.0	19.5	60	6	1
20500C-4D	●	5.0	20.0	22.0	60	6	1
GSX 20550C-4D	●	5.5	22.0	24.0	60	6	1
20600C-4D	●	6.0	24.0	—	60	6	2
20650C-4D	●	6.5	26.0	28.0	70	8	1
20700C-4D	●	7.0	28.0	30.0	80	8	1
20750C-4D	●	7.5	30.0	32.0	80	8	1
GSX 20800C-4D	●	8.0	32.0	—	80	8	2
20850C-4D	●	8.5	34.0	36.0	90	10	1
20900C-4D	●	9.0	36.0	38.0	90	10	1
20950C-4D	●	9.5	38.0	40.0	90	10	1
21000C-4D	●	10.0	40.0	—	90	10	2
GSX 21050C-4D	●	10.5	42.0	44.5	100	12	1
21100C-4D	●	11.0	44.0	46.5	100	12	1
21150C-4D	●	11.5	46.0	48.5	100	12	1
21200C-4D	●	12.0	48.0	—	100	12	2
21300C-4D	●	13.0	52.0	55.5	110	16	1
GSX 21400C-4D	●	14.0	56.0	59.5	110	16	1
21500C-4D	●	15.0	60.0	63.5	120	16	1
21600C-4D	●	16.0	64.0	—	120	16	2
21700C-4D	●	17.0	68.0	72.5	130	20	1
21800C-4D	●	18.0	72.0	76.5	130	20	1
GSX 21900C-4D	●	19.0	76.0	80.5	140	20	1
22000C-4D	●	20.0	80.0	—	140	20	2
22500C-4D	●	25.0	100.0	—	160	25	2

Grade: ACF20

Identification Code

GSX 2 0100 C - 4D

Series Code No. of Flutes Dia. Corner Style Cutting Edge Length
 C: Gash Land

Endmills

I

Square

Radius

Ballnose

Multi-Purpose

General-Purpose

High Efficiency

Hardened Steel

Roughing

Non-Ferrous Metal

CFRP

Coated

Uncoated

GSX 20000C-4D type

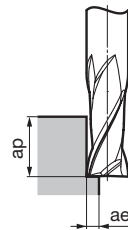

Recommended Cutting Conditions

1. For stable machining performance use rigid, high-precision machines and holders.
2. Use air blow when dry machining.
3. Use wet machining for stainless steel, heat-resistant alloy, and titanium alloy applications.
4. In some cases, chattering may occur in early stages of milling but will cease after 2m of cutting.
5. If chatter is a problem, reduce the spindle speed and feed rate indicated in the table below by the same ratio, or reduce the depth of cut.
6. This series is not recommended for groove milling.
7. If the machine cannot achieve the recommended spindle speed, please use the maximum spindle speed available.

Side Milling

Work Material Cutting Conditions	Structural Steel SS		Carbon Steel SC (150 to 250HB)		Cast Iron FC		Alloy Steel SCM (25 to 35HRC)		Tempered Steel, Hardened Steel NAK , HPM (35 to 45HRC)		Hardened Steel (45 to 55HRC)		Stainless Steel SUS304,SUS316		Heat-Resistant Alloy Titanium Alloy		
	DC (mm)	Spindle Speed (min ⁻¹)	Feed Rate (mm/min)	Spindle Speed (min ⁻¹)	Feed Rate (mm/min)	Spindle Speed (min ⁻¹)	Feed Rate (mm/min)	Spindle Speed (min ⁻¹)	Feed Rate (mm/min)	Spindle Speed (min ⁻¹)	Feed Rate (mm/min)	Spindle Speed (min ⁻¹)	Feed Rate (mm/min)	Spindle Speed (min ⁻¹)	Feed Rate (mm/min)	Spindle Speed (min ⁻¹)	Feed Rate (mm/min)
1.0	9,000	130	9,000	130	9,000	130	7,000	95	6,500	50	4,500	30	5,400	40	4,500	25	
2.0	4,500	180	4,500	180	4,500	180	3,500	120	3,200	70	2,300	40	2,700	50	2,300	35	
4.0	2,250	240	2,250	240	2,250	240	1,750	160	1,600	95	1,200	60	1,350	65	1,200	40	
6.0	1,500	300	1,500	300	1,500	300	1,150	170	1,050	110	800	70	900	70	800	50	
8.0	1,100	260	1,100	260	1,100	260	850	170	800	110	600	70	660	70	600	50	
10.0	900	250	900	250	900	250	700	160	650	110	460	70	540	70	460	50	
12.0	750	240	750	240	750	240	580	160	520	110	400	70	450	70	400	50	
16.0	550	200	550	200	550	200	440	140	400	95	300	55	330	60	300	45	
20.0	450	180	450	180	450	180	350	120	320	85	240	45	270	50	240	40	
25.0	360	140	360	140	360	140	280	95	250	65	190	35	210	40	192	30	
Standard Depth of Cut	ap	3.5DC						0.04DC						3.0DC			
	ae	0.08DC															

Endmills

I

Square

Radius

Ballnose

Multi-Purpose

General-Purpose

High Efficiency

Hardened Steel

Roughing

Non-Ferrous Metal

CFRP

Coated

Uncoated

GSX 30000C-1.5D type

- General Steel
- Carbon Steel
- Alloy Steel
- Pre-hardened Steel
- Tempered Steel / Die Steel
- Hardened Steel 45 to 55HRC
- Stainless Steel
- Ti Alloy Heat Resistant Alloy
- Cast Iron

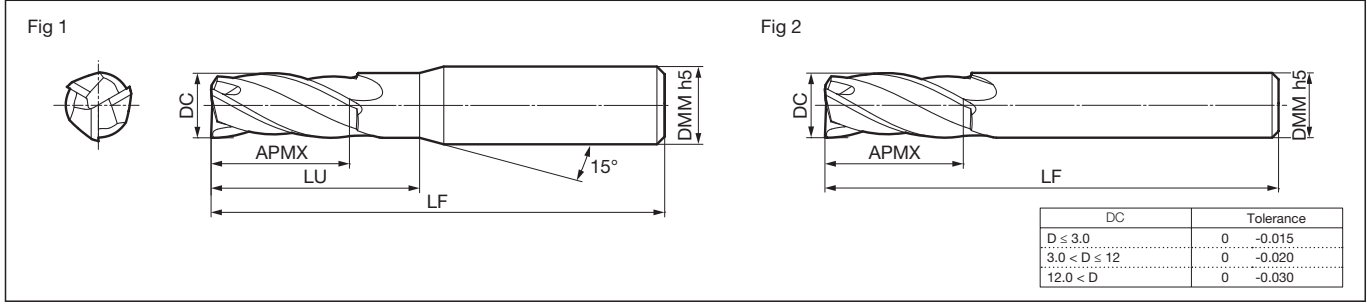

Body

Dimensions (mm)

Cat. No.	Stock	Dia. DC	Cutting Edge Length APMX	Neck Length LU	Overall Length LF	Shank Dia. DMM	Fig
GSX 30100C-1.5D	●	1.0	1.5	2.5	40	4	1
30150C-1.5D	●	1.5	2.3	3.3	40	4	1
30200C-1.5D	●	2.0	3.0	4.0	40	4	1
30250C-1.5D	●	2.5	3.8	4.8	40	4	1
30300C-1.5D	●	3.0	4.5	6.0	45	6	1
GSX 30400C-1.5D	●	4.0	6.0	7.5	45	6	1
30500C-1.5D	●	5.0	7.5	9.5	50	6	1
30600C-1.5D	●	6.0	9.0	—	50	6	2
30700C-1.5D	●	7.0	11.0	13.0	60	8	1
30800C-1.5D	●	8.0	12.0	—	60	8	2
GSX 30900C-1.5D	●	9.0	14.0	16.0	70	10	1
31000C-1.5D	●	10.0	15.0	—	70	10	2
31200C-1.5D	●	12.0	18.0	—	75	12	2

Grade: ACF20

Identification Code

GSX 3 0100 C - 1.5D

Series Code No. of Flutes Dia. Corner Style C: Gash Land Cutting Edge Length

Endmills

I

Square

Radius

Ballnose

Multi-Purpose

General-Purpose

High Efficiency

Hardened Steel

Roughing

Non-Ferrous Metal

CFRP

Coated

Uncoated

GSX 30000C-1.5D type

Recommended Cutting Conditions

1. For stable machining performance use rigid, high-precision machines and holders.
2. Use air blow when dry machining.
3. Use wet machining for stainless steel, heat-resistant alloy, and titanium alloy applications.
4. If the machine cannot achieve the recommended spindle speed, please use the maximum spindle speed available.

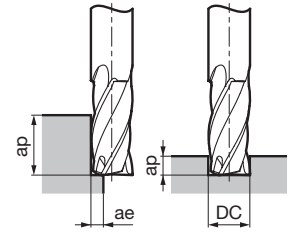

Side Milling

Work Material	Structural Steel SS		Carbon Steel SC (150 to 250HB)		Cast Iron FC		Alloy Steel SCM (25 to 35HRC)		Tempered Steel, Hardened Steel NAK, HPM (35 to 45HRC)		Hardened Steel (45 to 55HRC)		Stainless Steel SUS304,SUS316		Heat-Resistant Alloy Titanium Alloy		
	DC (mm)	Spindle Speed (min ⁻¹)	Feed Rate (mm/min)	Spindle Speed (min ⁻¹)	Feed Rate (mm/min)	Spindle Speed (min ⁻¹)	Feed Rate (mm/min)	Spindle Speed (min ⁻¹)	Feed Rate (mm/min)	Spindle Speed (min ⁻¹)	Feed Rate (mm/min)	Spindle Speed (min ⁻¹)	Feed Rate (mm/min)	Spindle Speed (min ⁻¹)	Feed Rate (mm/min)	Spindle Speed (min ⁻¹)	Feed Rate (mm/min)
	1.0	19,600	300	19,600	300	19,600	300	18,300	210	12,700	130	9,000	80	11,000	90	9,000	65
	2.0	11,200	410	11,200	410	11,200	410	10,500	280	7,300	170	5,300	100	6,400	120	5,300	90
	4.0	6,400	550	6,400	550	6,400	550	6,000	370	4,200	230	3,000	140	3,600	150	3,000	120
	6.0	4,600	670	4,600	670	4,600	670	4,300	460	3,000	270	2,200	170	2,700	180	2,200	130
	8.0	3,400	670	3,400	670	3,400	670	3,200	460	2,200	270	1,600	170	2,000	180	1,600	130
	10.0	2,800	670	2,800	670	2,800	670	2,600	460	1,800	270	1,300	170	1,600	180	1,300	130
	12.0	2,300	670	2,300	670	2,300	670	2,200	460	1,500	270	1,100	170	1,300	180	1,100	130
Standard Depth of Cut	ap	1.5DC										1.0DC					
	ae	0.05DC										0.02DC					

Groove Milling

Work Material	Structural Steel SS		Carbon Steel SC (150 to 250HB)		Cast Iron FC		Alloy Steel SCM (25 to 35HRC)		Tempered Steel, Hardened Steel NAK, HPM (35 to 45HRC)		Hardened Steel (45 to 55HRC)		Stainless Steel SUS304,SUS316		Heat-Resistant Alloy Titanium Alloy		
	DC (mm)	Spindle Speed (min ⁻¹)	Feed Rate (mm/min)	Spindle Speed (min ⁻¹)	Feed Rate (mm/min)	Spindle Speed (min ⁻¹)	Feed Rate (mm/min)	Spindle Speed (min ⁻¹)	Feed Rate (mm/min)	Spindle Speed (min ⁻¹)	Feed Rate (mm/min)	Spindle Speed (min ⁻¹)	Feed Rate (mm/min)	Spindle Speed (min ⁻¹)	Feed Rate (mm/min)	Spindle Speed (min ⁻¹)	Feed Rate (mm/min)
	1.0	19,600	240	19,600	300	19,600	300	18,300	210	12,700	130	9,000	80	11,000	65	4,500	25
	2.0	11,200	320	11,200	410	11,200	410	10,500	280	7,300	170	5,300	100	6,400	85	2,650	35
	4.0	6,400	450	6,400	550	6,400	550	6,000	370	4,200	230	3,000	140	3,600	100	1,500	50
	6.0	4,600	540	4,600	670	4,600	670	4,300	460	3,000	270	2,200	170	2,650	130	1,150	55
	8.0	3,400	540	3,400	670	3,400	670	3,200	460	2,200	270	1,600	170	2,000	130	800	55
	10.0	2,800	540	2,800	670	2,800	670	2,600	460	1,800	270	1,300	170	1,600	130	650	55
	12.0	2,300	540	2,300	670	2,300	670	2,200	460	1,500	270	1,100	170	1,300	130	500	55
Standard Depth of Cut	ap	0.2DC		0.5DC						0.2DC		0.05DC		0.2DC			

Endmills

I

Square

Radius

Ballnose

Multi-Purpose

General-Purpose

High Efficiency

Hardened Steel

Roughing

Non-Ferrous Metal

CFRP

Coated

Uncoated

GSX 30000C-2D type

- General Steel
- Carbon Steel
- Alloy Steel
- Pre-hardened Steel
- Tempered Steel / Die Steel
- Hardened Steel 45 to 55HRC
- Stainless Steel
- Ti Alloy Heat Resistant Alloy
- Cast Iron

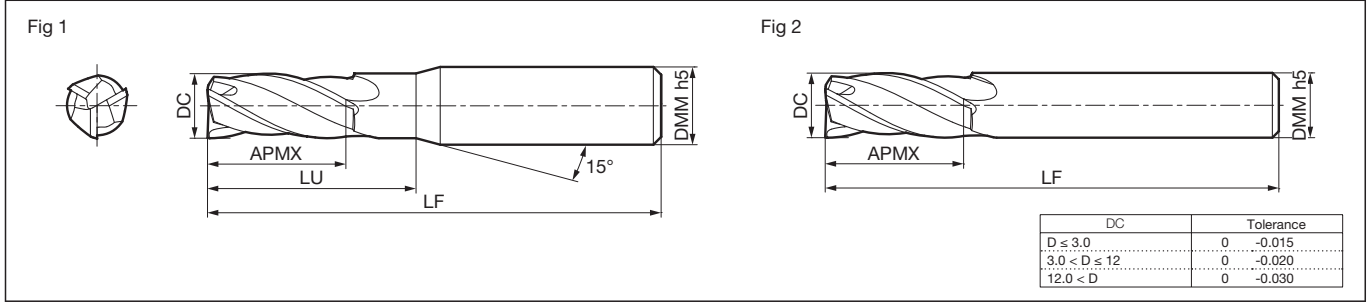

Body

Dimensions (mm)

Cat. No.	Stock	Dia. DC	Cutting Edge Length APMX	Neck Length LU	Overall Length LF	Shank Dia. DMM	Fig
GSX 30100C-2D	●	1.0	2.5	3.5	40	4	1
30150C-2D	●	1.5	3.8	4.8	40	4	1
30200C-2D	●	2.0	5.0	6.0	40	4	1
30250C-2D	●	2.5	6.3	7.3	40	4	1
30300C-2D	●	3.0	7.5	9.0	45	6	1
GSX 30400C-2D	●	4.0	11.0	12.5	45	6	1
30500C-2D	●	5.0	13.0	15.0	50	6	1
30600C-2D	●	6.0	13.0	—	50	6	2
30700C-2D	●	7.0	16.0	18.0	60	8	1
30800C-2D	●	8.0	19.0	—	60	8	2
GSX 30900C-2D	●	9.0	19.0	21.0	70	10	1
31000C-2D	●	10.0	22.0	—	70	10	2
31200C-2D	●	12.0	26.0	—	75	12	2

Grade: ACF20

Identification Code

GSX 3 0100 C - 2D

Series Code No. of Flutes Dia. Corner Style Cutting Edge Length
 C: Gash Land

Endmills

I

Square

Radius

Ballnose

Multi-Purpose

General-Purpose

High Efficiency

Hardened Steel

Roughing

Non-Ferrous Metal

CFRP

Coated

Uncoated

GSX 30000C-2D type

Recommended Cutting Conditions

1. For stable machining performance use rigid, high-precision machines and holders.
2. Use air blow when dry machining.
3. Use wet machining for stainless steel, heat-resistant alloy, and titanium alloy applications.
4. If the machine cannot achieve the recommended spindle speed, please use the maximum spindle speed available.

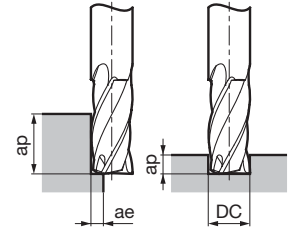

Side Milling

Work Material Cutting Conditions	Structural Steel SS		Carbon Steel SC (150 to 250HB)		Cast Iron FC		Alloy Steel SCM (25 to 35HRC)		Tempered Steel, Hardened Steel NAK, HPM (35 to 45HRC)		Hardened Steel (45 to 55HRC)		Stainless Steel SUS304, SUS316		Heat-Resistant Alloy Titanium Alloy		
	DC (mm)	Spindle Speed (min ⁻¹)	Feed Rate (mm/min)	Spindle Speed (min ⁻¹)	Feed Rate (mm/min)	Spindle Speed (min ⁻¹)	Feed Rate (mm/min)	Spindle Speed (min ⁻¹)	Feed Rate (mm/min)	Spindle Speed (min ⁻¹)	Feed Rate (mm/min)	Spindle Speed (min ⁻¹)	Feed Rate (mm/min)	Spindle Speed (min ⁻¹)	Feed Rate (mm/min)	Spindle Speed (min ⁻¹)	Feed Rate (mm/min)
	1.0	19,600	300	19,600	300	19,600	300	18,300	210	12,700	130	9,000	80	11,000	90	9,000	65
	2.0	11,200	410	11,200	410	11,200	410	10,500	280	7,300	170	5,300	100	6,400	120	5,300	90
	4.0	6,400	550	6,400	550	6,400	550	6,000	370	4,200	230	3,000	140	3,600	150	3,000	120
	6.0	4,600	670	4,600	670	4,600	670	4,300	460	3,000	270	2,200	170	2,700	180	2,200	130
	8.0	3,400	670	3,400	670	3,400	670	3,200	460	2,200	270	1,600	170	2,000	180	1,600	130
	10.0	2,800	670	2,800	670	2,800	670	2,600	460	1,800	270	1,300	170	1,600	180	1,300	130
	12.0	2,300	670	2,300	670	2,300	670	2,200	460	1,500	270	1,100	170	1,300	180	1,100	130
Standard Depth of Cut	ap	1.5DC										1.0DC					
	ae	0.05DC										0.02DC					

Groove Milling

Work Material Cutting Conditions	Structural Steel SS		Carbon Steel SC (150 to 250HB)		Cast Iron FC		Alloy Steel SCM (25 to 35HRC)		Tempered Steel, Hardened Steel NAK, HPM (35 to 45HRC)		Hardened Steel (45 to 55HRC)		Stainless Steel SUS304, SUS316		Heat-Resistant Alloy Titanium Alloy		
	DC (mm)	Spindle Speed (min ⁻¹)	Feed Rate (mm/min)	Spindle Speed (min ⁻¹)	Feed Rate (mm/min)	Spindle Speed (min ⁻¹)	Feed Rate (mm/min)	Spindle Speed (min ⁻¹)	Feed Rate (mm/min)	Spindle Speed (min ⁻¹)	Feed Rate (mm/min)	Spindle Speed (min ⁻¹)	Feed Rate (mm/min)	Spindle Speed (min ⁻¹)	Feed Rate (mm/min)	Spindle Speed (min ⁻¹)	Feed Rate (mm/min)
	1.0	19,600	240	19,600	300	19,600	300	18,300	210	12,700	130	9,000	80	11,000	65	4,500	25
	2.0	11,200	320	11,200	410	11,200	410	10,500	280	7,300	170	5,300	100	6,400	85	2,650	35
	4.0	6,400	450	6,400	550	6,400	550	6,000	370	4,200	230	3,000	140	3,600	100	1,500	50
	6.0	4,600	540	4,600	670	4,600	670	4,300	460	3,000	270	2,200	170	2,650	130	1,150	55
	8.0	3,400	540	3,400	670	3,400	670	3,200	460	2,200	270	1,600	170	2,000	130	800	55
	10.0	2,800	540	2,800	670	2,800	670	2,600	460	1,800	270	1,300	170	1,600	130	650	55
	12.0	2,300	540	2,300	670	2,300	670	2,200	460	1,500	270	1,100	170	1,300	130	500	55
Standard Depth of Cut	ap	0.2DC		0.5DC						0.2DC		0.05DC		0.2DC			

Endmills

I

Square

Radius

Ballnose

Multi-Purpose

General-Purpose

High Efficiency

Hardened Steel

Roughing

Non-Ferrous Metal

CFRP

Coated

Uncoated

GSX 4000C-1.5D type

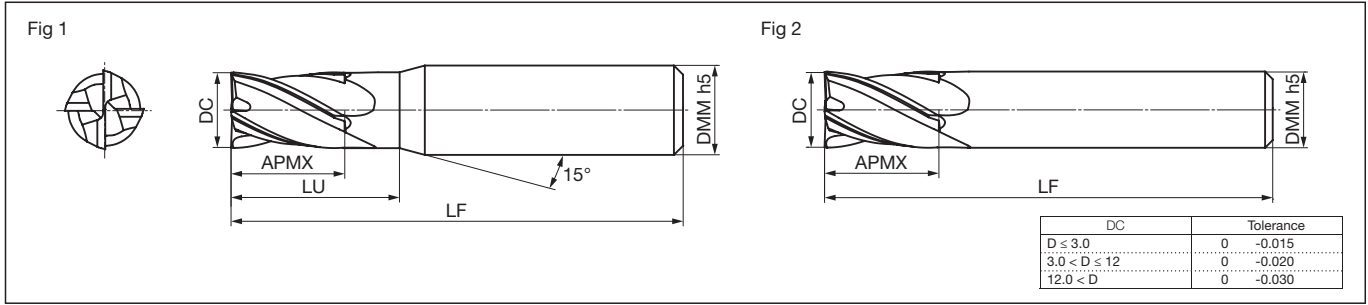
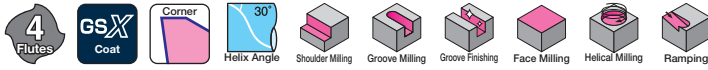

Body Dimensions (mm)

Cat. No.	Stock	Dia. DC	Cutting Edge Length APMX	Neck Length LU	Overall Length LF	Shank Dia. DMM	Fig
GSX 40100C-1.5D	●	1.0	1.5	2.5	40	4	1
40150C-1.5D	●	1.5	2.3	3.3	40	4	1
40200C-1.5D	●	2.0	3.0	4.0	40	4	1
40250C-1.5D	●	2.5	3.8	4.8	40	4	1
40300C-1.5D	●	3.0	4.5	6.0	45	6	1
GSX 40350C-1.5D	●	3.5	5.3	6.8	45	6	1
40400C-1.5D	●	4.0	6.0	7.5	45	6	1
40450C-1.5D	●	4.5	6.8	8.3	50	6	1
40500C-1.5D	●	5.0	7.5	9.5	50	6	1
40550C-1.5D	●	5.5	8.3	10.3	50	6	1
GSX 40600C-1.5D	●	6.0	9.0	—	50	6	2
40650C-1.5D	●	6.5	10.0	12.0	60	8	1
40700C-1.5D	●	7.0	11.0	13.0	60	8	1
40750C-1.5D	●	7.5	12.0	14.0	60	8	1
40800C-1.5D	●	8.0	12.0	—	60	8	2
GSX 40850C-1.5D	●	8.5	13.0	15.0	70	10	1
40900C-1.5D	●	9.0	14.0	16.0	70	10	1
40950C-1.5D	●	9.5	15.0	17.0	70	10	1
41000C-1.5D	●	10.0	15.0	—	70	10	2
41050C-1.5D	●	10.5	16.0	18.5	75	12	1
GSX 41100C-1.5D	●	11.0	17.0	19.5	75	12	1
41150C-1.5D	●	11.5	18.0	20.5	75	12	1
41200C-1.5D	●	12.0	18.0	—	75	12	2
41300C-1.5D	●	13.0	20.0	23.5	90	16	1
41400C-1.5D	●	14.0	21.0	24.5	90	16	1
GSX 41500C-1.5D	●	15.0	23.0	26.5	90	16	1
41600C-1.5D	●	16.0	24.0	—	90	16	2
41700C-1.5D	●	17.0	26.0	30.5	100	20	1
41800C-1.5D	●	18.0	27.0	31.5	100	20	1
41900C-1.5D	●	19.0	29.0	33.5	100	20	1
GSX 42000C-1.5D	●	20.0	30.0	—	100	20	2
42500C-1.5D	●	25.0	38.0	—	120	25	2

Grade: ACF20

Identification Code

GSX 4 0100 C - 1.5D

Series Code No. of Flutes Dia. Corner Style Cutting Edge Length
 C: Gash Land

GSX 40000C-1.5D type

Recommended Cutting Conditions

1. For stable machining performance use rigid, high-precision machines and holders.
2. Use air blow when dry machining.
3. Use wet machining for stainless steel, heat-resistant alloy, and titanium alloy applications.
4. If the machine cannot achieve the recommended spindle speed, please use the maximum spindle speed available.

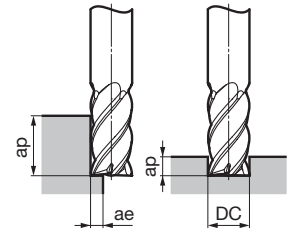

Side Milling

Work Material Cutting Conditions	Structural Steel SS		Carbon Steel SC (150 to 250HB)		Cast Iron FC		Alloy Steel SCM (25 to 35HRC)		Tempered Steel, Hardened Steel NAK, HPM (35 to 45HRC)		Hardened Steel (45 to 55HRC)		Stainless Steel SUS304,SUS316		Heat-Resistant Alloy Titanium Alloy		
	DC (mm)	Spindle Speed (min ⁻¹)	Feed Rate (mm/min)	Spindle Speed (min ⁻¹)	Feed Rate (mm/min)	Spindle Speed (min ⁻¹)	Feed Rate (mm/min)	Spindle Speed (min ⁻¹)	Feed Rate (mm/min)	Spindle Speed (min ⁻¹)	Feed Rate (mm/min)	Spindle Speed (min ⁻¹)	Feed Rate (mm/min)	Spindle Speed (min ⁻¹)	Feed Rate (mm/min)	Spindle Speed (min ⁻¹)	Feed Rate (mm/min)
1.0	24,000	470	24,000	470	24,000	470	21,000	290	14,500	180	10,500	120	12,600	120	10,500	85	
2.0	12,800	570	12,800	570	12,800	570	12,000	380	8,300	230	6,000	150	7,200	160	6,000	110	
4.0	6,800	730	6,800	730	6,800	730	6,400	490	4,400	300	3,200	200	3,800	210	3,200	130	
6.0	4,600	780	4,600	780	4,600	780	4,300	520	3,000	320	2,200	210	2,650	220	2,200	150	
8.0	3,400	780	3,400	780	3,400	780	3,200	520	2,200	320	1,600	210	2,000	220	1,600	150	
10.0	2,800	780	2,800	780	2,800	780	2,600	520	1,800	320	1,300	210	1,500	220	1,300	150	
12.0	2,300	780	2,300	780	2,300	780	2,200	520	1,500	320	1,100	210	1,300	220	1,100	150	
16.0	1,700	650	1,700	650	1,700	650	1,600	420	1,100	280	800	170	1,000	180	800	120	
20.0	1,350	600	1,350	600	1,350	600	1,300	380	900	260	650	150	800	160	650	100	
25.0	1,050	470	1,050	470	1,050	470	1,050	300	720	210	520	120	640	130	520	80	
Standard Depth of Cut	ap	1.5DC										1.0DC					
	ae	0.05DC										0.02DC					

Side Milling (Using High Speed Machining Centre)

Work Material Cutting Conditions	Structural Steel SS		Carbon Steel SC (150 to 250HB)		Cast Iron FC		Alloy Steel SCM (25 to 35HRC)		Tempered Steel, Hardened Steel NAK, HPM (35 to 45HRC)		Hardened Steel (45 to 55HRC)		Stainless Steel SUS304,SUS316		Heat-Resistant Alloy Titanium Alloy		
	DC (mm)	Spindle Speed (min ⁻¹)	Feed Rate (mm/min)	Spindle Speed (min ⁻¹)	Feed Rate (mm/min)	Spindle Speed (min ⁻¹)	Feed Rate (mm/min)	Spindle Speed (min ⁻¹)	Feed Rate (mm/min)	Spindle Speed (min ⁻¹)	Feed Rate (mm/min)	Spindle Speed (min ⁻¹)	Feed Rate (mm/min)	Spindle Speed (min ⁻¹)	Feed Rate (mm/min)	Spindle Speed (min ⁻¹)	Feed Rate (mm/min)
1.0	60,000	1,200	60,000	1,200	60,000	1,200	60,000	850	60,000	720	48,000	500	32,000	300	—	—	
2.0	47,800	2,200	47,800	2,200	47,800	2,200	47,800	1,600	39,800	1,200	31,800	900	15,900	400	—	—	
4.0	23,900	2,600	23,900	2,600	23,900	2,600	23,900	1,900	19,900	1,400	15,900	1,100	8,000	490	—	—	
6.0	16,000	2,700	16,000	2,700	16,000	2,700	16,000	2,000	13,300	1,500	10,600	1,200	5,300	520	—	—	
8.0	12,000	2,700	12,000	2,700	12,000	2,700	12,000	2,000	10,000	1,500	8,000	1,200	4,000	520	—	—	
10.0	9,600	2,700	9,600	2,700	9,600	2,700	9,600	2,000	8,000	1,500	6,400	1,200	3,200	520	—	—	
12.0	8,000	2,700	8,000	2,700	8,000	2,700	8,000	2,000	6,700	1,500	5,300	1,200	2,700	520	—	—	
16.0	6,000	2,200	6,000	2,200	6,000	2,200	6,000	1,600	5,000	1,200	4,000	900	2,000	450	—	—	
20.0	4,800	2,000	4,800	2,000	4,800	2,000	4,800	1,400	4,000	1,100	3,200	750	1,600	380	—	—	
25.0	3,800	1,500	3,800	1,500	3,800	1,500	3,800	1,150	3,200	850	2,600	600	1,300	300	—	—	
Standard Depth of Cut	ap	1.5DC										1.0DC					
	ae	0.05DC										0.02DC					

Groove Milling

Work Material Cutting Conditions	Structural Steel SS		Carbon Steel SC (150 to 250HB)		Cast Iron FC		Alloy Steel SCM (25 to 35HRC)		Tempered Steel, Hardened Steel NAK, HPM (35 to 45HRC)		Hardened Steel (45 to 55HRC)		Stainless Steel SUS304,SUS316		Heat-Resistant Alloy Titanium Alloy		
	DC (mm)	Spindle Speed (min ⁻¹)	Feed Rate (mm/min)	Spindle Speed (min ⁻¹)	Feed Rate (mm/min)	Spindle Speed (min ⁻¹)	Feed Rate (mm/min)	Spindle Speed (min ⁻¹)	Feed Rate (mm/min)	Spindle Speed (min ⁻¹)	Feed Rate (mm/min)	Spindle Speed (min ⁻¹)	Feed Rate (mm/min)	Spindle Speed (min ⁻¹)	Feed Rate (mm/min)	Spindle Speed (min ⁻¹)	Feed Rate (mm/min)
1.0	24,000	380	24,000	470	24,000	470	21,000	290	14,500	180	10,500	120	12,600	85	5,200	30	
2.0	12,800	460	12,800	570	12,800	570	12,000	380	8,300	230	6,000	150	7,200	110	3,000	40	
4.0	6,800	580	6,800	730	6,800	730	5,400	490	4,400	300	3,200	200	3,800	130	1,600	55	
6.0	4,600	620	4,600	780	4,600	780	4,300	520	3,000	320	2,200	210	2,650	160	1,100	65	
8.0	3,400	620	3,400	780	3,400	780	3,200	520	2,200	320	1,600	210	2,000	160	800	65	
10.0	2,800	620	2,800	780	2,800	780	2,600	520	1,800	320	1,300	210	1,600	160	650	65	
12.0	2,300	620	2,300	780	2,300	780	2,200	520	1,500	320	1,100	210	1,300	160	550	65	
16.0	1,700	520	1,700	560	1,700	560	1,600	420	1,100	280	800	170	1,000	130	400	55	
20.0	1,350	480	1,350	600	1,350	600	1,300	380	900	260	650	150	800	110	320	50	
25.0	1,080	384	1,080	480	1,080	480	1,040	304	720	208	520	120	640	88	256	40	
Standard Depth of Cut	ap	0.2DC		0.5DC				0.2DC		0.05DC		0.2DC					

Endmills

I

Square

Radius

Ballnose

Multi-Purpose

General-Purpose

High Efficiency

Hardened Steel

Roughing

Non-Ferrous Metal

CFRP

Coated

Uncoated

GSX 4000S-2D type

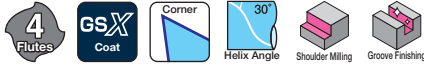

Fig 1

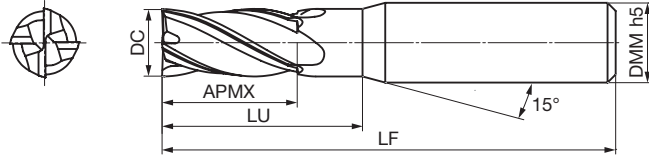
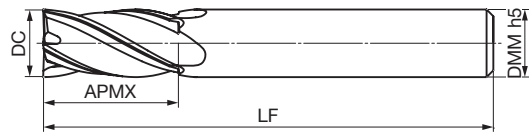

Fig 2



DC	Tolerance
D ≤ 3.0	0 -0.015
3.0 < D ≤ 12	0 -0.020
12.0 < D	0 -0.030

Body

Dimensions (mm)

Cat. No.	Stock	Dia. DC	Cutting Edge Length APMX	Neck Length LU	Overall Length LF	Shank Dia. DMM	Fig
GSX 40100S-2D	●	1.0	2.5	3.5	40	4	1
40100S-2D-S3	●	1.0	2.5	3.5	38	3	1
40150S-2D	●	1.5	3.8	4.8	40	4	1
40200S-2D	●	2.0	5.0	6.0	40	4	1
40200S-2D-S3	●	2.0	5.0	6.0	38	3	1
GSX 40250S-2D	●	2.5	6.3	7.3	40	4	1
40300S-2D	●	3.0	7.5	9.0	45	6	1
40300S-2D-S3	●	3.0	7.5	—	38	3	2
40350S-2D	●	3.5	8.8	10.0	45	6	1
40400S-2D	●	4.0	11.0	14.0	45	6	1
GSX 40400S-2D-S4	●	4.0	11.0	—	45	4	2
40450S-2D	●	4.5	11.3	12.8	50	6	1
40500S-2D	●	5.0	13.0	19.6	50	6	1
40550S-2D	●	5.5	13.0	19.6	50	6	1
40600S-2D	●	6.0	13.0	—	50	6	2
GSX 40650S-2D	●	6.5	13.0	19.6	60	8	1
40700S-2D	●	7.0	16.0	21.1	60	8	1
40750S-2D	●	7.5	16.0	21.1	60	8	1
40800S-2D	●	8.0	19.0	—	60	8	2
40850S-2D	●	8.5	19.0	24.1	70	10	1
GSX 40900S-2D	●	9.0	19.0	24.1	70	10	1
40950S-2D	●	9.5	19.0	24.1	70	10	1
41000S-2D	●	10.0	22.0	—	70	10	2
41050S-2D	●	10.5	22.0	24.5	75	12	1
41100S-2D	●	11.0	22.0	24.5	75	12	1
GSX 41150S-2D	●	11.5	23.0	25.5	75	12	1
41200S-2D	●	12.0	26.0	—	75	12	2
41300S-2D	●	13.0	26.0	29.5	90	16	1
41350S-2D	●	13.5	27.0	30.5	90	16	1
41400S-2D	●	14.0	28.0	31.5	90	16	1
GSX 41500S-2D	●	15.0	30.0	33.5	90	16	1
41600S-2D	●	16.0	32.0	—	90	16	2
41700S-2D	●	17.0	35.0	39.5	100	20	1
41800S-2D	●	18.0	40.0	44.5	100	20	1
41900S-2D	●	19.0	40.0	44.5	100	20	1
GSX 42000S-2D	●	20.0	40.0	—	100	20	2
42200S-2D	●	22.0	44.0	49.0	110	25	1
42400S-2D	●	24.0	48.0	53.0	120	25	1
42500S-2D	●	25.0	50.0	—	120	25	2

Grade: ACF20

Identification Code

GSX 4 0100 S - 2D - S3

Series Code No. of Flutes Dia. Corner Style Cutting Edge Length Shank Dia.

S: Sharp Edge

GSX 40000S-2D type

Recommended Cutting Conditions

1. For stable machining performance use rigid, high-precision machines and holders.
2. Use air blow when dry machining.
3. Use wet machining for stainless steel, heat-resistant alloy, and titanium alloy applications.
4. If chatter is a problem, reduce the spindle speed and feed rate indicated in the table below by the same ratio, or reduce the depth of cut.
5. This series is not recommended for groove milling.
6. If the machine cannot achieve the recommended spindle speed, please use the maximum spindle speed available.

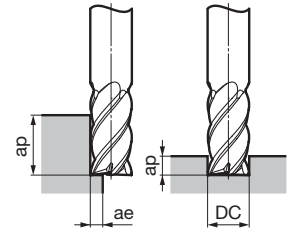

Side Milling

Work Material Cutting Conditions	Structural Steel SS		Carbon Steel SC (150 to 250HB)		Cast Iron FC		Alloy Steel SCM (25 to 35HRC)		Tempered Steel, Hardened Steel NAK, HPM (35 to 45HRC)		Hardened Steel (45 to 55HRC)		Stainless Steel SUS304,SUS316		Heat-Resistant Alloy Titanium Alloy		
	DC (mm)	Spindle Speed (min ⁻¹)	Feed Rate (mm/min)	Spindle Speed (min ⁻¹)	Feed Rate (mm/min)	Spindle Speed (min ⁻¹)	Feed Rate (mm/min)	Spindle Speed (min ⁻¹)	Feed Rate (mm/min)	Spindle Speed (min ⁻¹)	Feed Rate (mm/min)	Spindle Speed (min ⁻¹)	Feed Rate (mm/min)	Spindle Speed (min ⁻¹)	Feed Rate (mm/min)	Spindle Speed (min ⁻¹)	Feed Rate (mm/min)
1.0	22,000	360	22,000	360	22,000	360	19,000	220	13,000	140	9,500	90	11,300	90	9,500	65	
2.0	11,500	440	11,500	440	11,500	440	11,000	290	7,500	180	5,400	110	6,500	120	5,400	85	
4.0	6,000	560	6,000	560	6,000	560	5,800	370	4,000	230	2,900	150	3,400	160	2,900	100	
6.0	4,200	600	4,200	600	4,200	600	4,000	400	2,700	240	2,000	160	2,400	170	2,000	120	
8.0	3,000	600	3,000	600	3,000	600	2,800	400	2,000	240	1,450	160	1,800	170	1,450	120	
10.0	2,500	600	2,500	600	2,500	600	2,350	400	1,600	240	1,200	160	1,450	170	1,200	120	
12.0	2,100	600	2,100	600	2,100	600	2,000	400	1,350	240	1,000	160	1,200	170	1,000	120	
16.0	1,500	500	1,500	500	1,500	500	1,450	320	1,000	210	750	130	900	140	750	90	
20.0	1,200	460	1,200	460	1,200	460	1,150	290	800	200	600	110	700	120	600	75	
25.0	960	370	960	370	960	370	920	230	640	160	480	85	560	95	480	60	
Standard Depth of Cut	ap	2.0DC										0.01DC					
	ae	0.03DC															

Groove Finishing

Work Material Cutting Conditions	Structural Steel SS		Carbon Steel SC (150 to 250HB)		Cast Iron FC		Alloy Steel SCM (25 to 35HRC)		Tempered Steel, Hardened Steel NAK, HPM (35 to 45HRC)		Hardened Steel (45 to 55HRC)		Stainless Steel SUS304,SUS316		Heat-Resistant Alloy Titanium Alloy	
	DC (mm)	Spindle Speed (min ⁻¹)	Feed Rate (mm/min)	Spindle Speed (min ⁻¹)	Feed Rate (mm/min)	Spindle Speed (min ⁻¹)	Feed Rate (mm/min)	Spindle Speed (min ⁻¹)	Feed Rate (mm/min)	Spindle Speed (min ⁻¹)	Feed Rate (mm/min)	Spindle Speed (min ⁻¹)	Feed Rate (mm/min)	Spindle Speed (min ⁻¹)	Feed Rate (mm/min)	Spindle Speed (min ⁻¹)
1.0	22,000	360	22,000	360	22,000	360	19,000	220	13,000	140	9,500	90	11,300	90	9,500	65
2.0	11,500	440	11,500	440	11,500	440	11,000	290	7,500	180	5,400	110	6,500	120	5,400	85
4.0	6,000	560	6,000	560	6,000	560	5,800	370	4,000	230	2,900	150	3,400	160	2,900	100
6.0	4,200	600	4,200	600	4,200	600	4,000	400	2,700	240	2,000	160	2,400	170	2,000	120
8.0	3,000	600	3,000	600	3,000	600	2,800	400	2,000	240	1,450	160	1,800	170	1,450	120
10.0	2,500	600	2,500	600	2,500	600	2,350	400	1,600	240	1,200	160	1,450	170	1,200	120
12.0	2,100	600	2,100	600	2,100	600	2,000	400	1,350	240	1,000	160	1,200	170	1,000	120
16.0	1,500	500	1,500	500	1,500	500	1,450	320	1,000	210	750	130	900	140	750	90
20.0	1,200	460	1,200	460	1,200	460	1,150	290	800	200	600	110	700	120	600	75
25.0	960	370	960	370	960	370	920	230	640	160	480	85	560	95	480	60
Standard Depth of Cut	ap	1.5DC														
	ae	Below 0.02DC														

Endmills
I
Square
Radius
Ballnose
Multi-Purpose
General-Purpose
High Efficiency
Hardened Steel
Roughing
Non-Ferrous Metal
CFRP
Coated
Uncoated

GSX 40000C-2D type

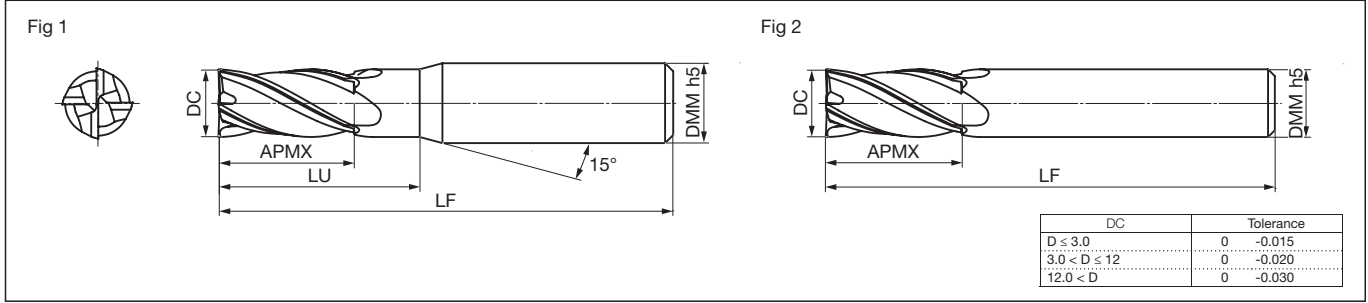
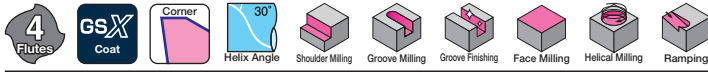

Body Dimensions (mm)

Cat. No.	Stock	Dia. DC	Cutting Edge Length APMX	Neck Length LU	Overall Length LF	Shank Dia. DMM	Fig
GSX 40100C-2D	●	1.0	2.0	3.0	40	4	1
40150C-2D	●	1.5	3.0	4.0	40	4	1
40200C-2D	●	2.0	4.0	5.0	40	4	1
40250C-2D	●	2.5	5.0	6.0	40	4	1
40300C-2D	●	3.0	6.0	7.5	45	6	1
GSX 40350C-2D	●	3.5	7.0	8.5	45	6	1
40400C-2D	●	4.0	8.0	9.5	45	6	1
40450C-2D	●	4.5	9.0	10.5	50	6	1
40500C-2D	●	5.0	10.0	12.0	50	6	1
40550C-2D	●	5.5	11.0	13.0	50	6	1
GSX 40600C-2D	●	6.0	12.0	—	50	6	2
40650C-2D	●	6.5	13.0	15.0	60	8	1
40700C-2D	●	7.0	14.0	16.0	60	8	1
40750C-2D	●	7.5	15.0	17.0	60	8	1
40800C-2D	●	8.0	16.0	—	60	8	2
GSX 40850C-2D	●	8.5	17.0	19.0	70	10	1
40900C-2D	●	9.0	18.0	20.0	70	10	1
40950C-2D	●	9.5	19.0	21.0	70	10	1
41000C-2D	●	10.0	20.0	—	70	10	2
41050C-2D	●	10.5	21.0	23.5	75	12	1
GSX 41100C-2D	●	11.0	22.0	24.5	75	12	1
41150C-2D	●	11.5	23.0	25.5	75	12	1
41200C-2D	●	12.0	24.0	—	75	12	2
41300C-2D	●	13.0	26.0	29.5	90	16	1
41400C-2D	●	14.0	28.0	31.5	90	16	1
GSX 41500C-2D	●	15.0	30.0	33.5	90	16	1
41600C-2D	●	16.0	32.0	—	90	16	2
41700C-2D	●	17.0	34.0	39.5	100	20	1
41800C-2D	●	18.0	36.0	40.5	100	20	1
41900C-2D	●	19.0	38.0	42.5	100	20	1
GSX 42000C-2D	●	20.0	40.0	—	100	20	2
42500C-2D	●	25.0	50.0	—	120	25	2

Grade: ACF20

Identification Code

GSX 4 0100 C - 2D

Series Code No. of Flutes Dia. Corner Style Cutting Edge Length
 C: Gash Land

Endmills

I

Square

Radius

Ballnose

Multi-Purpose

General-Purpose

High Efficiency

Hardened Steel

Roughing

Non-Ferrous Metal

CFRP

Coated

Uncoated

GSX 40000C-2D type

Recommended Cutting Conditions

1. For stable machining performance use rigid, high-precision machines and holders.
2. Use air blow when dry machining.
3. Use wet machining for stainless steel, heat-resistant alloy, and titanium alloy applications.
4. If chatter is a problem, reduce the spindle speed and feed rate indicated in the table below by the same ratio, or reduce the depth of cut.
5. If the machine cannot achieve the recommended spindle speed, please use the maximum spindle speed available.

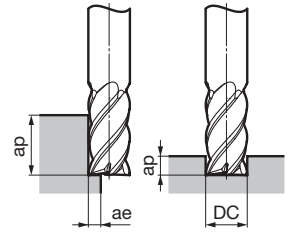

Side Milling

Work Material Cutting Conditions	Structural Steel SS		Carbon Steel SC (150 to 250HB)		Cast Iron FC		Alloy Steel SCM (25 to 35HRC)		Tempered Steel, Hardened Steel NAK, HPM (35 to 45HRC)		Hardened Steel (45 to 55HRC)		Stainless Steel SUS304,SUS316		Heat-Resistant Alloy Titanium Alloy		
	Spindle Speed (min ⁻¹)	Feed Rate (mm/min)	Spindle Speed (min ⁻¹)	Feed Rate (mm/min)	Spindle Speed (min ⁻¹)	Feed Rate (mm/min)	Spindle Speed (min ⁻¹)	Feed Rate (mm/min)	Spindle Speed (min ⁻¹)	Feed Rate (mm/min)	Spindle Speed (min ⁻¹)	Feed Rate (mm/min)	Spindle Speed (min ⁻¹)	Feed Rate (mm/min)	Spindle Speed (min ⁻¹)	Feed Rate (mm/min)	
DC (mm)																	
1.0	24,000	470	24,000	470	24,000	470	21,000	290	14,500	180	10,500	120	12,600	120	10,500	85	
2.0	12,800	570	12,800	570	12,800	570	12,000	380	8,300	230	6,000	150	7,200	160	6,000	110	
4.0	6,800	730	6,800	730	6,800	730	6,400	490	4,400	300	3,200	200	3,800	210	3,200	130	
6.0	4,600	780	4,600	780	4,600	780	4,300	520	3,000	320	2,200	210	2,650	220	2,200	150	
8.0	3,400	780	3,400	780	3,400	780	3,200	520	2,200	320	1,600	210	2,000	220	1,600	150	
10.0	2,800	780	2,800	780	2,800	780	2,600	520	1,800	320	1,300	210	1,500	220	1,300	150	
12.0	2,300	780	2,300	780	2,300	780	2,200	520	1,500	320	1,100	210	1,300	220	1,100	150	
16.0	1,700	650	1,700	650	1,700	650	1,600	420	1,100	280	800	170	1,000	180	800	120	
20.0	1,350	600	1,350	600	1,350	600	1,300	380	900	260	650	150	800	160	650	100	
25.0	1,000	480	1,000	480	1,000	480	1,000	300	700	200	500	120	640	120	500	80	
Standard Depth of Cut	ap	1.5DC										1.0DC					
	ae	0.05DC										0.02DC					

Side Milling (Using High Speed Machining Centre)

Work Material Cutting Conditions	Structural Steel SS		Carbon Steel SC (150 to 250HB)		Cast Iron FC		Alloy Steel SCM (25 to 35HRC)		Tempered Steel, Hardened Steel NAK, HPM (35 to 45HRC)		Hardened Steel (45 to 55HRC)		Stainless Steel SUS304,SUS316		Heat-Resistant Alloy Titanium Alloy		
	Spindle Speed (min ⁻¹)	Feed Rate (mm/min)	Spindle Speed (min ⁻¹)	Feed Rate (mm/min)	Spindle Speed (min ⁻¹)	Feed Rate (mm/min)	Spindle Speed (min ⁻¹)	Feed Rate (mm/min)	Spindle Speed (min ⁻¹)	Feed Rate (mm/min)	Spindle Speed (min ⁻¹)	Feed Rate (mm/min)	Spindle Speed (min ⁻¹)	Feed Rate (mm/min)	Spindle Speed (min ⁻¹)	Feed Rate (mm/min)	
DC (mm)																	
1.0	60,000	1,200	60,000	1,200	60,000	1,200	60,000	850	60,000	720	48,000	500	32,000	300	—	—	
2.0	47,800	2,200	47,800	2,200	47,800	2,200	47,800	1,600	39,800	1,200	31,800	900	15,900	400	—	—	
4.0	23,900	2,600	23,900	2,600	23,900	2,600	23,900	1,900	19,900	1,400	15,900	1,100	8,000	490	—	—	
6.0	16,000	2,700	16,000	2,700	16,000	2,700	16,000	2,000	13,300	1,500	10,600	1,200	5,300	520	—	—	
8.0	12,000	2,700	12,000	2,700	12,000	2,700	12,000	2,000	10,000	1,500	8,000	1,200	4,000	520	—	—	
10.0	9,600	2,700	9,600	2,700	9,600	2,700	9,600	2,000	8,000	1,500	6,400	1,200	3,200	520	—	—	
12.0	8,000	2,700	8,000	2,700	8,000	2,700	8,000	2,000	6,700	1,500	5,300	1,200	2,700	520	—	—	
16.0	6,000	2,200	6,000	2,200	6,000	2,200	6,000	1,600	5,000	1,200	4,000	900	2,000	450	—	—	
20.0	4,800	2,000	4,800	2,000	4,800	2,000	4,800	1,400	4,000	1,100	3,200	750	1,600	380	—	—	
25.0	3,800	1,500	3,800	1,500	3,800	1,500	3,800	1,100	3,200	900	2,500	600	1,300	300	—	—	
Standard Depth of Cut	ap	1.5DC										1.0DC					
	ae	0.05DC										0.02DC					

Groove Milling

Work Material Cutting Conditions	Structural Steel SS		Carbon Steel SC (150 to 250HB)		Cast Iron FC		Alloy Steel SCM (25 to 35HRC)		Tempered Steel, Hardened Steel NAK, HPM (35 to 45HRC)		Hardened Steel (45 to 55HRC)		Stainless Steel SUS304,SUS316		Heat-Resistant Alloy Titanium Alloy	
	Spindle Speed (min ⁻¹)	Feed Rate (mm/min)	Spindle Speed (min ⁻¹)	Feed Rate (mm/min)	Spindle Speed (min ⁻¹)	Feed Rate (mm/min)	Spindle Speed (min ⁻¹)	Feed Rate (mm/min)	Spindle Speed (min ⁻¹)	Feed Rate (mm/min)	Spindle Speed (min ⁻¹)	Feed Rate (mm/min)	Spindle Speed (min ⁻¹)	Feed Rate (mm/min)	Spindle Speed (min ⁻¹)	Feed Rate (mm/min)
DC (mm)																
1.0	24,000	380	24,000	470	24,000	470	21,000	290	14,500	180	10,500	120	12,600	85	5,200	30
2.0	12,800	460	12,800	570	12,800	570	12,000	380	8,300	230	6,000	150	7,200	110	3,000	40
4.0	6,800	580	6,800	730	6,800	730	5,400	490	4,400	300	3,200	200	3,800	130	1,600	55
6.0	4,600	620	4,600	780	4,600	780	4,300	520	3,000	320	2,200	210	2,650	160	1,100	65
8.0	3,400	620	3,400	780	3,400	780	3,200	520	2,200	320	1,600	210	2,000	160	800	65
10.0	2,800	620	2,800	780	2,800	780	2,600	520	1,800	320	1,300	210	1,600	160	650	65
12.0	2,300	620	2,300	780	2,300	780	2,200	520	1,500	320	1,100	210	1,300	160	550	65
16.0	1,700	520	1,700	560	1,700	560	1,600	420	1,100	280	800	170	1,000	130	400	55
20.0	1,350	480	1,350	600	1,350	600	1,300	380	900	260	650	150	800	110	320	50
25.0	1,000	380	1,000	450	1,000	450	1,000	300	700	200	500	120	640	80	250	40
Standard Depth of Cut	ap	0.2DC		0.5DC				0.2DC		0.05DC		0.2DC				

Endmills
I
Square
Radius
Ballnose
Multi-Purpose
General-Purpose
High Efficiency
Hardened Steel
Roughing
Non-Ferrous Metal
CFRP
Coated
Uncoated

GSX 4000S-3D type

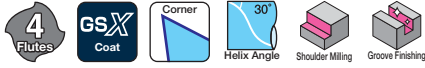

Fig 1

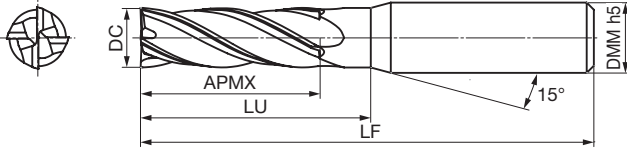
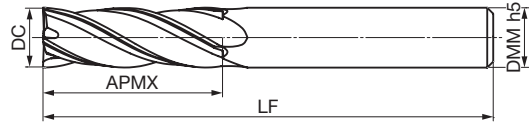

Fig 2



DC	Tolerance
D ≤ 3.0	0 -0.015
3.0 < D ≤ 12	0 -0.020
12.0 < D	0 -0.030

Body

Dimensions (mm)

Cat. No.	Stock	Dia. DC	Cutting Edge Length APMX	Neck Length LU	Overall Length LF	Shank Dia. DMM	Fig
GSX 40100S-3D	●	1.0	3.0	4.0	40	4	1
40150S-3D	●	1.5	4.5	5.5	40	4	1
40200S-3D	●	2.0	6.0	7.0	40	4	1
40250S-3D	●	2.5	8.0	9.0	40	4	1
40300S-3D	●	3.0	9.0	10.5	50	6	1
GSX 40350S-3D	●	3.5	11.0	12.5	50	6	1
40400S-3D	●	4.0	12.0	13.5	50	6	1
40450S-3D	●	4.5	15.0	16.5	50	6	1
40500S-3D	●	5.0	15.0	17.0	50	6	1
40550S-3D	●	5.5	18.0	20.0	50	6	1
GSX 40600S-3D	●	6.0	18.0	—	50	6	2
40650S-3D	●	6.5	20.0	22.0	70	8	1
40700S-3D	●	7.0	21.0	23.0	70	8	1
40750S-3D	●	7.5	23.0	25.0	70	8	1
40800S-3D	●	8.0	24.0	—	70	8	2
GSX 40850S-3D	●	8.5	26.0	28.0	75	10	1
40900S-3D	●	9.0	27.0	29.0	75	10	1
40950S-3D	●	9.5	29.0	31.0	75	10	1
41000S-3D	●	10.0	30.0	—	90	10	2
41050S-3D	●	10.5	32.0	34.5	90	12	1
GSX 41100S-3D	●	11.0	33.0	35.5	90	12	1
41150S-3D	●	11.5	35.0	37.5	90	12	1
41200S-3D	●	12.0	36.0	—	90	12	2
41300S-3D	●	13.0	39.0	42.5	100	16	1
41400S-3D	●	14.0	42.0	45.5	110	16	1
GSX 41500S-3D	●	15.0	45.0	48.5	110	16	1
41600S-3D	●	16.0	48.0	—	110	16	2
41700S-3D	●	17.0	51.0	55.5	110	20	1
41800S-3D	●	18.0	54.0	58.5	120	20	1
41900S-3D	●	19.0	57.0	61.5	120	20	1
GSX 42000S-3D	●	20.0	60.0	—	120	20	2
42200S-3D	●	22.0	66.0	71.0	130	25	1
42500S-3D	●	25.0	75.0	—	130	25	2

Grade: ACF20

Identification Code

GSX 4 0100 S - 3D

Series Code No. of Flutes Dia. Corner Style Cutting Edge Length
 S: Sharp Edge

Endmills
I

Square

Radius

Ballnose

Multi-Purpose

General-Purpose

High Efficiency

Hardened Steel

Roughing

Non-Ferrous Metal

CFRP

Coated

Uncoated

GSX 40000S-3D type

Recommended Cutting Conditions

1. For stable machining performance use rigid, high-precision machines and holders.
2. Use air blow when dry machining.
3. Use wet machining for stainless steel, heat-resistant alloy, and titanium alloy applications.
4. In some cases, chatter may occur in early stages of milling but will cease after 2m of cutting.
5. If chatter is a problem, reduce the spindle speed and feed rate indicated in the table below by the same ratio, or reduce the depth of cut.
6. If the machine cannot achieve the recommended spindle speed, please use the maximum spindle speed available.

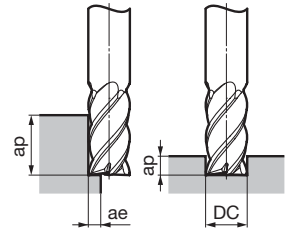

Side Milling

Work Material Cutting Conditions	Structural Steel SS		Carbon Steel SC (150 to 250HB)		Cast Iron FC		Alloy Steel SCM (25 to 35HRC)		Tempered Steel, Hardened Steel NAK, HPM (35 to 45HRC)		Hardened Steel (45 to 55HRC)		Stainless Steel SUS304,SUS316		Heat-Resistant Alloy Titanium Alloy	
	Spindle Speed (min ⁻¹)	Feed Rate (mm/min)	Spindle Speed (min ⁻¹)	Feed Rate (mm/min)	Spindle Speed (min ⁻¹)	Feed Rate (mm/min)	Spindle Speed (min ⁻¹)	Feed Rate (mm/min)	Spindle Speed (min ⁻¹)	Feed Rate (mm/min)	Spindle Speed (min ⁻¹)	Feed Rate (mm/min)	Spindle Speed (min ⁻¹)	Feed Rate (mm/min)	Spindle Speed (min ⁻¹)	Feed Rate (mm/min)
DC (mm)																
1.0	18,500	250	18,500	250	18,500	250	17,000	150	11,500	100	8,000	65	9,400	65	8,000	45
2.0	9,400	250	9,400	250	9,400	250	8,500	200	6,700	130	4,000	65	4,600	90	4,000	60
4.0	4,500	350	4,500	350	4,500	350	4,300	250	3,500	210	2,000	110	2,300	110	2,000	70
6.0	3,100	400	3,100	400	3,100	400	2,800	300	2,400	220	1,300	120	1,500	120	1,300	90
8.0	2,300	380	2,300	380	2,300	380	2,100	300	1,800	220	950	120	1,100	120	900	90
10.0	1,800	350	1,800	350	1,800	350	1,700	300	1,400	220	700	120	900	120	800	90
12.0	1,500	350	1,500	350	1,500	350	1,400	300	1,200	220	650	110	750	120	650	90
16.0	1,100	300	1,100	300	1,100	300	1,000	240	900	190	480	90	550	100	490	70
20.0	900	280	900	280	900	280	850	210	700	170	400	80	440	90	400	60
25.0	720	220	720	220	720	220	680	170	560	130	320	60	352	70	320	50
Standard Depth of Cut	2.5DC								2.0DC							
	Below ø3: 0.02DC, Above ø3 to Below ø8: 0.05DC, Above ø8: 0.07DC								0.01DC							

Groove Finishing

Work Material Cutting Conditions	Structural Steel SS		Carbon Steel SC (150 to 250HB)		Cast Iron FC		Alloy Steel SCM (25 to 35HRC)		Tempered Steel, Hardened Steel NAK, HPM (35 to 45HRC)		Hardened Steel (45 to 55HRC)		Stainless Steel SUS304,SUS316		Heat-Resistant Alloy Titanium Alloy	
	Spindle Speed (min ⁻¹)	Feed Rate (mm/min)	Spindle Speed (min ⁻¹)	Feed Rate (mm/min)	Spindle Speed (min ⁻¹)	Feed Rate (mm/min)	Spindle Speed (min ⁻¹)	Feed Rate (mm/min)	Spindle Speed (min ⁻¹)	Feed Rate (mm/min)	Spindle Speed (min ⁻¹)	Feed Rate (mm/min)	Spindle Speed (min ⁻¹)	Feed Rate (mm/min)	Spindle Speed (min ⁻¹)	Feed Rate (mm/min)
DC (mm)																
1.0	18,500	250	18,500	250	18,500	250	17,000	150	11,500	100	8,000	65	9,400	65	8,000	45
2.0	9,400	250	9,400	250	9,400	250	8,500	200	6,700	130	4,000	65	4,600	90	4,000	60
4.0	4,500	350	4,500	350	4,500	350	4,300	250	3,500	210	2,000	110	2,300	110	2,000	70
6.0	3,100	400	3,100	400	3,100	400	2,800	300	2,400	220	1,300	120	1,500	120	1,300	90
8.0	2,300	380	2,300	380	2,300	380	2,100	300	1,800	220	950	120	1,100	120	900	90
10.0	1,800	350	1,800	350	1,800	350	1,700	300	1,400	220	700	120	900	120	800	90
12.0	1,500	350	1,500	350	1,500	350	1,400	300	1,200	220	650	110	750	120	650	90
16.0	1,100	300	1,100	300	1,100	300	1,000	240	900	190	480	90	550	100	490	70
20.0	900	280	900	280	900	280	850	210	700	170	400	80	440	90	400	60
25.0	720	220	720	220	720	220	680	170	560	130	320	60	352	70	320	50
Standard Depth of Cut	1.5DC															
	Below 0.02DC															

Endmills
I
Square
Radius
Ballnose
Multi-Purpose
General-Purpose
High Efficiency
Hardened Steel
Roughing
Non-Ferrous Metal
CFRP
Coated
Uncoated

GSX 40000C-3D type

- General Steel
- Carbon Steel
- Alloy Steel
- Pre-hardened Steel
- Tempered Steel / Die Steel
- Hardened Steel 45 to 55HRC
- Hardened Steel 55 to 60HRC
- Stainless Steel
- Ti Alloy Heat Resistant Alloy
- Cast Iron

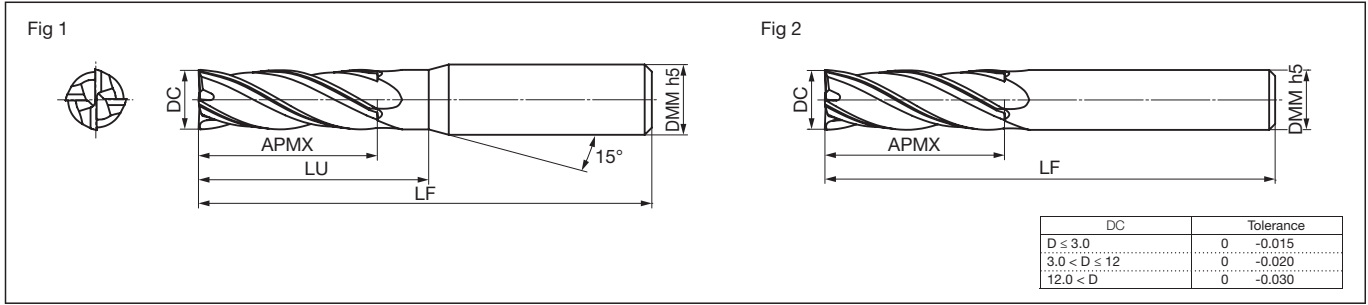
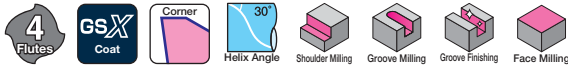

Body Dimensions (mm)

Cat. No.	Stock	Dia. DC	Cutting Edge Length APMX	Neck Length LU	Overall Length LF	Shank Dia. DMM	Fig
GSX 40100C-3D	●	1.0	3.0	4.0	40	4	1
40150C-3D	●	1.5	4.5	5.5	40	4	1
40200C-3D	●	2.0	6.0	7.0	40	4	1
40250C-3D	●	2.5	7.5	8.5	40	4	1
40300C-3D	●	3.0	9.0	10.5	50	6	1
GSX 40350C-3D	●	3.5	11.0	12.5	50	6	1
40400C-3D	●	4.0	12.0	13.5	50	6	1
40450C-3D	●	4.5	14.0	15.5	50	6	1
40500C-3D	●	5.0	15.0	17.0	50	6	1
40550C-3D	●	5.5	17.0	19.0	50	6	1
GSX 40600C-3D	●	6.0	18.0	—	50	6	2
40650C-3D	●	6.5	20.0	22.0	70	8	1
40700C-3D	●	7.0	21.0	23.0	70	8	1
40750C-3D	●	7.5	23.0	25.0	70	8	1
40800C-3D	●	8.0	24.0	—	70	8	2
GSX 40850C-3D	●	8.5	26.0	28.0	75	10	1
40900C-3D	●	9.0	27.0	29.0	75	10	1
40950C-3D	●	9.5	29.0	31.0	75	10	1
41000C-3D	●	10.0	30.0	—	90	10	2
41050C-3D	●	10.5	32.0	34.5	90	12	1
GSX 41100C-3D	●	11.0	33.0	35.5	90	12	1
41150C-3D	●	11.5	35.0	37.5	90	12	1
41200C-3D	●	12.0	36.0	—	90	12	2
41300C-3D	●	13.0	39.0	42.5	100	16	1
41400C-3D	●	14.0	42.0	45.5	110	16	1
GSX 41500C-3D	●	15.0	45.0	48.5	110	16	1
41600C-3D	●	16.0	48.0	—	110	16	2
41700C-3D	●	17.0	51.0	55.5	110	20	1
41800C-3D	●	18.0	54.0	58.5	120	20	1
41900C-3D	●	19.0	57.0	61.5	120	20	1
GSX 42000C-3D	●	20.0	60.0	—	120	20	2
42500C-3D	●	25.0	75.0	—	130	25	2

Grade: ACF20

Identification Code

GSX 4 0100 C - 3D

Series Code No. of Flutes Dia. Corner Style C: Gash Land Cutting Edge Length

Endmills

Square

Radius

Ballnose

Multi-Purpose

General-Purpose

High Efficiency

Hardened Steel

Roughing

Non-Ferrous Metal

CFRP

Coated

Uncoated

GSX 40000C-3D type

Recommended Cutting Conditions

1. For stable machining performance use rigid, high-precision machines and holders.
2. Use air blow when dry machining.
3. Use wet machining for stainless steel, heat-resistant alloy, and titanium alloy applications.
4. In some cases, chatter may occur in early stages of milling but will cease after 2m of cutting.
5. If chatter is a problem, reduce the spindle speed and feed rate indicated in the table below by the same ratio, or reduce the depth of cut.
6. If the machine cannot achieve the recommended spindle speed, please use the maximum spindle speed available.

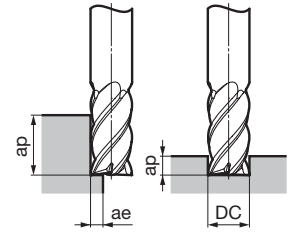

Side Milling

Work Material Cutting Conditions	Structural Steel SS		Carbon Steel SC (150 to 250HB)		Cast Iron FC		Alloy Steel SCM (25 to 35HRC)		Tempered Steel, Hardened Steel NAK, HPM (35 to 45HRC)		Hardened Steel (45 to 55HRC)		Stainless Steel SUS304,SUS316		Heat-Resistant Alloy Titanium Alloy	
	DC (mm)	Spindle Speed (min ⁻¹)	Feed Rate (mm/min)	Spindle Speed (min ⁻¹)	Feed Rate (mm/min)	Spindle Speed (min ⁻¹)	Feed Rate (mm/min)	Spindle Speed (min ⁻¹)	Feed Rate (mm/min)	Spindle Speed (min ⁻¹)	Feed Rate (mm/min)	Spindle Speed (min ⁻¹)	Feed Rate (mm/min)	Spindle Speed (min ⁻¹)	Feed Rate (mm/min)	Spindle Speed (min ⁻¹)
1.0	21,000	360	21,000	360	21,000	360	19,000	220	13,000	140	9,000	90	10,500	90	9,000	65
2.0	10,500	360	10,500	360	10,500	360	9,600	290	7,500	180	4,500	110	5,200	120	4,500	85
4.0	5,200	500	5,200	500	5,200	500	4,800	370	4,000	280	2,250	150	2,600	160	2,250	100
6.0	3,500	560	3,500	560	3,500	560	3,200	400	2,700	300	1,500	160	1,700	170	1,500	120
8.0	2,600	520	2,600	520	2,600	520	2,400	400	2,000	300	1,100	160	1,300	170	1,100	120
10.0	2,100	500	2,100	500	2,100	500	1,900	400	1,600	300	900	160	1,000	160	900	120
12.0	1,750	500	1,750	500	1,750	500	1,600	400	1,350	300	750	150	850	160	750	120
16.0	1,300	420	1,300	420	1,300	420	1,200	330	1,000	260	550	120	650	140	550	100
20.0	1,050	380	1,050	380	1,050	380	950	290	800	230	450	110	500	120	450	90
25.0	840	300	840	300	840	300	760	230	640	180	360	85	400	95	360	70
Standard Depth of Cut	ap	2.5DC										2.0DC				
	ae	Below ø3: 0.05DC, Above ø3 to Below ø8: 0.1DC, Above ø8: 0.15DC										0.02DC				

Groove Milling

Work Material Cutting Conditions	Structural Steel SS		Carbon Steel SC (150 to 250HB)		Cast Iron FC		Alloy Steel SCM (25 to 35HRC)		Tempered Steel, Hardened Steel NAK, HPM (35 to 45HRC)		Hardened Steel (45 to 55HRC)		Stainless Steel SUS304,SUS316		Heat-Resistant Alloy Titanium Alloy	
	DC (mm)	Spindle Speed (min ⁻¹)	Feed Rate (mm/min)	Spindle Speed (min ⁻¹)	Feed Rate (mm/min)	Spindle Speed (min ⁻¹)	Feed Rate (mm/min)	Spindle Speed (min ⁻¹)	Feed Rate (mm/min)	Spindle Speed (min ⁻¹)	Feed Rate (mm/min)	Spindle Speed (min ⁻¹)	Feed Rate (mm/min)	Spindle Speed (min ⁻¹)	Feed Rate (mm/min)	Spindle Speed (min ⁻¹)
1.0	16,600	140	16,600	140	16,600	140	15,500	100	10,500	100	7,500	70	9,400	60	3,750	20
2.0	9,500	160	9,500	160	9,500	160	9,000	180	6,200	120	4,500	90	5,200	80	2,250	30
4.0	5,200	160	5,200	180	5,200	180	4,800	160	3,400	110	2,200	65	2,600	70	1,250	25
6.0	3,500	160	3,500	200	3,500	200	3,200	160	2,550	120	1,500	65	1,700	70	950	25
8.0	2,600	160	2,600	200	2,600	200	2,400	160	1,900	120	1,100	65	1,300	70	700	25
10.0	2,100	160	2,100	200	2,100	200	1,900	160	1,500	120	900	65	1,000	70	550	25
12.0	1,750	160	1,750	200	1,750	200	1,600	160	1,250	120	750	65	850	70	450	25
16.0	1,300	160	1,300	200	1,300	200	1,200	160	950	120	550	65	650	70	350	25
20.0	1,050	160	1,050	200	1,050	200	950	160	750	120	450	65	500	70	280	55
25.0	840	128	840	160	840	160	760	128	600	96	360	52	400	56	224	44
Standard Depth of Cut	ap	0.1DC		0.2DC						0.05DC		0.1DC				

Endmills
I
Square
Radius
Ballnose
Multi-Purpose
General-Purpose
High Efficiency
Hardened Steel
Roughing
Non-Ferrous Metal
CFRP
Coated
Uncoated

GSX 4000S-4D type

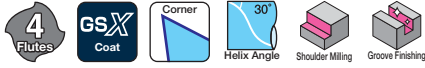

Fig 1

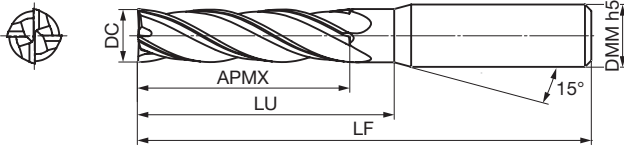
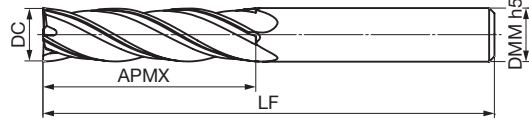

Fig 2



DC	Tolerance
D ≤ 3.0	0 -0.015
3.0 < D ≤ 12	0 -0.020
12.0 < D	0 -0.030

Body

Dimensions (mm)

Cat. No.	Stock	Dia. DC	Cutting Edge Length APMX	Neck Length LU	Overall Length LF	Shank Dia. DMM	Fig
GSX 40100S-4D	●	1.0	4.0	5.0	40	4	1
40150S-4D	●	1.5	6.0	7.0	40	4	1
40200S-4D	●	2.0	8.0	9.0	40	4	1
40250S-4D	●	2.5	10.0	11.0	50	4	1
40300S-4D	●	3.0	12.0	13.5	50	6	1
GSX 40350S-4D	●	3.5	14.0	15.5	50	6	1
40400S-4D	●	4.0	16.0	17.5	50	6	1
40450S-4D	●	4.5	18.0	19.5	60	6	1
40500S-4D	●	5.0	20.0	22.0	60	6	1
40550S-4D	●	5.5	22.0	24.0	60	6	1
GSX 40600S-4D	●	6.0	24.0	—	60	6	2
40650S-4D	●	6.5	26.0	28.0	70	8	1
40700S-4D	●	7.0	28.0	30.0	80	8	1
40750S-4D	●	7.5	30.0	32.0	80	8	1
40800S-4D	●	8.0	32.0	—	80	8	2
GSX 40850S-4D	●	8.5	34.0	36.0	90	10	1
40900S-4D	●	9.0	36.0	38.0	90	10	1
40950S-4D	●	9.5	39.0	41.0	90	10	1
41000S-4D	●	10.0	40.0	—	90	10	2
41050S-4D	●	10.5	42.0	44.5	100	12	1
GSX 41100S-4D	●	11.0	44.0	46.5	100	12	1
41150S-4D	●	11.5	46.0	48.5	100	12	1
41200S-4D	●	12.0	48.0	—	100	12	2
41300S-4D	●	13.0	52.0	55.5	110	16	1
41400S-4D	●	14.0	56.0	59.5	110	16	1
GSX 41500S-4D	●	15.0	60.0	63.5	120	16	1
41600S-4D	●	16.0	64.0	—	120	16	2
41700S-4D	●	17.0	68.0	72.5	130	20	1
41800S-4D	●	18.0	72.0	76.5	130	20	1
41900S-4D	●	19.0	76.0	80.5	140	20	1
GSX 42000S-4D	●	20.0	80.0	—	140	20	2
42500S-4D	●	25.0	100.0	—	160	25	2

Grade: ACF20

Identification Code

GSX 4 0100 S - 4D

Series Code No. of Flutes Dia. Corner Style Cutting Edge Length
 S: Sharp Edge

Endmills

I

Square

Radius

Ballnose

Multi-Purpose

General-Purpose

High Efficiency

Hardened Steel

Roughing

Non-Ferrous Metal

CFRP

Coated

Uncoated

GSX 40000S-4D type

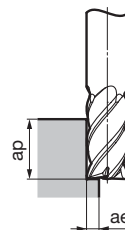

Recommended Cutting Conditions

1. For stable machining performance use rigid, high-precision machines and holders.
2. Use air blow when dry machining.
3. Use wet machining for stainless steel, heat-resistant alloy, and titanium alloy applications.
4. In some cases, chattering may occur in early stages of milling but will cease after 2m of cutting.
5. If chatter is a problem, reduce the spindle speed and feed rate indicated in the table below by the same ratio, or reduce the depth of cut.
6. If the machine cannot achieve the recommended spindle speed, please use the maximum spindle speed available.

Side Milling

Work Material Cutting Conditions	Structural Steel SS		Carbon Steel SC (150 to 250HB)		Cast Iron FC		Alloy Steel SCM (25 to 35HRC)		Tempered Steel, Hardened Steel NAK, HPM (35 to 45HRC)		Hardened Steel (45 to 55HRC)		Stainless Steel SUS304,SUS316		Heat-Resistant Alloy Titanium Alloy		
	DC (mm)	Spindle Speed (min ⁻¹)	Feed Rate (mm/min)	Spindle Speed (min ⁻¹)	Feed Rate (mm/min)	Spindle Speed (min ⁻¹)	Feed Rate (mm/min)	Spindle Speed (min ⁻¹)	Feed Rate (mm/min)	Spindle Speed (min ⁻¹)	Feed Rate (mm/min)	Spindle Speed (min ⁻¹)	Feed Rate (mm/min)	Spindle Speed (min ⁻¹)	Feed Rate (mm/min)	Spindle Speed (min ⁻¹)	Feed Rate (mm/min)
1.0	7,950	120	7,950	120	7,950	120	6,250	70	5,750	50	4,000	35	4,850	35	4,000	35	
2.0	4,050	120	4,050	120	4,050	120	3,100	90	2,850	70	2,050	50	2,400	50	2,050	35	
4.0	1,950	170	1,950	170	1,950	170	1,650	100	1,400	90	710	35	1,200	45	1,050	30	
6.0	1,350	130	1,350	130	1,350	130	1,000	140	930	120	700	55	800	40	700	30	
8.0	970	190	970	190	970	190	740	140	720	120	520	55	560	40	490	30	
10.0	770	180	770	180	770	180	630	120	570	100	360	50	490	40	410	30	
12.0	640	170	640	170	640	170	500	120	460	100	350	55	400	40	350	30	
16.0	460	140	460	140	460	140	370	100	360	90	260	50	280	40	270	30	
20.0	390	130	390	130	390	130	310	90	280	70	210	45	240	40	210	30	
25.0	310	100	310	100	310	100	250	70	220	55	170	35	190	30	170	25	
Standard Depth of Cut	ap	2.5DC								2.0DC							
	ae	Below ø3: 0.02DC , Above ø3 to Below ø8: 0.05DC, Above ø8: 0.07DC								0.01DC							

Endmills

I

Square

Radius

Ballnose

Multi-Purpose

General-Purpose

High Efficiency

Hardened Steel

Roughing

Non-Ferrous Metal

CFRP

Coated

Uncoated

GSX 40000C-4D type

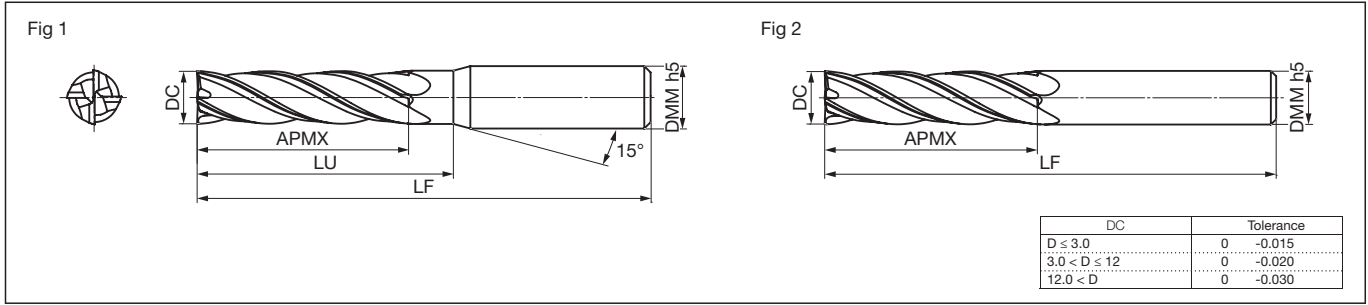

Body Dimensions (mm)

Cat. No.	Stock	Dia. DC	Cutting Edge Length APMX	Neck Length LU	Overall Length LF	Shank Dia. DMM	Fig
GSX 40100C-4D	●	1.0	4.0	5.0	40	4	1
40150C-4D	●	1.5	6.0	7.0	40	4	1
40200C-4D	●	2.0	8.0	9.0	40	4	1
40250C-4D	●	2.5	10.0	11.0	50	4	1
40300C-4D	●	3.0	12.0	13.5	50	6	1
GSX 40350C-4D	●	3.5	14.0	15.5	50	6	1
40400C-4D	●	4.0	16.0	17.5	50	6	1
40450C-4D	●	4.5	18.0	19.5	60	6	1
40500C-4D	●	5.0	20.0	22.0	60	6	1
40550C-4D	●	5.5	22.0	24.0	60	6	1
GSX 40600C-4D	●	6.0	24.0	—	60	6	2
40650C-4D	●	6.5	26.0	28.0	70	8	1
40700C-4D	●	7.0	28.0	30.0	80	8	1
40750C-4D	●	7.5	30.0	32.0	80	8	1
40800C-4D	●	8.0	32.0	—	80	8	2
GSX 40850C-4D	●	8.5	34.0	36.0	90	10	1
40900C-4D	●	9.0	36.0	28.0	90	10	1
40950C-4D	●	9.5	39.0	41.0	90	10	1
41000C-4D	●	10.0	40.0	—	90	10	2
41050C-4D	●	10.5	42.0	44.5	100	12	1
GSX 41100C-4D	●	11.0	44.0	46.5	100	12	1
41150C-4D	●	11.5	46.0	48.5	100	12	1
41200C-4D	●	12.0	48.0	—	100	12	2
41300C-4D	●	13.0	52.0	55.5	110	16	1
41400C-4D	●	14.0	56.0	59.5	110	16	1
GSX 41500C-4D	●	15.0	60.0	63.5	120	16	1
41600C-4D	●	16.0	64.0	—	120	16	2
41700C-4D	●	17.0	68.0	72.5	130	20	1
41800C-4D	●	18.0	72.0	76.5	130	20	1
41900C-4D	●	19.0	76.0	80.5	140	20	1
GSX 42000C-4D	●	20.0	80.0	—	140	20	2
42500C-4D	●	25.0	100.0	—	160	25	2

Grade: ACF20

Identification Code

GSX 4 0100 C - 4D

Series Code No. of Flutes Dia. Corner Style C: Gash Land Cutting Edge Length

Endmills

I

Square

Radius

Ballnose

Multi-Purpose

General-Purpose

High Efficiency

Hardened Steel

Roughing

Non-Ferrous Metal

CFRP

Coated

Uncoated

GSX 40000C-4D type

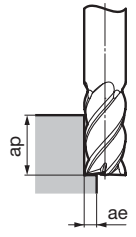

Recommended Cutting Conditions

1. For stable machining performance use rigid, high-precision machines and holders.
2. Use air blow when dry machining.
3. Use wet machining for stainless steel, heat-resistant alloy, and titanium alloy applications.
4. In some cases, chattering may occur in early stages of milling but will cease after 2m of cutting.
5. If chatter is a problem, reduce the spindle speed and feed rate indicated in the table below by the same ratio, or reduce the depth of cut.
6. This series is not recommended for groove milling.
7. If the machine cannot achieve the recommended spindle speed, please use the maximum spindle speed available.

Side Milling

Work Material Cutting Conditions	Structural Steel SS		Carbon Steel SC (150 to 250HB)		Cast Iron FC		Alloy Steel SCM (25 to 35HRC)		Tempered Steel, Hardened Steel NAK , HPM (35 to 45HRC)		Hardened Steel (45 to 55HRC)		Stainless Steel SUS304,SUS316		Heat-Resistant Alloy Titanium Alloy			
	DC (mm)	Spindle Speed (min ⁻¹)	Feed Rate (mm/min)	Spindle Speed (min ⁻¹)	Feed Rate (mm/min)	Spindle Speed (min ⁻¹)	Feed Rate (mm/min)	Spindle Speed (min ⁻¹)	Feed Rate (mm/min)	Spindle Speed (min ⁻¹)	Feed Rate (mm/min)	Spindle Speed (min ⁻¹)	Feed Rate (mm/min)	Spindle Speed (min ⁻¹)	Feed Rate (mm/min)	Spindle Speed (min ⁻¹)	Feed Rate (mm/min)	
1.0	9,000	140	9,000	140	9,000	140	7,000	80	6,500	60	4,500	40	5,400	40	4,500	40	4,500	40
2.0	4,500	140	4,500	140	4,500	140	3,500	100	3,200	80	2,300	55	2,700	55	2,300	40	2,300	40
4.0	2,250	200	2,250	200	2,250	200	1,750	120	1,600	100	1,200	60	1,350	50	1,200	35	1,200	35
6.0	1,500	250	1,500	250	1,500	250	1,150	160	1,050	140	800	65	900	45	800	35	800	35
8.0	1,100	220	1,100	220	1,100	220	850	160	800	130	600	65	660	45	600	35	600	35
10.0	900	210	900	210	900	210	700	140	650	120	460	65	540	45	460	35	460	35
12.0	750	200	750	200	750	200	580	140	520	110	400	65	450	45	400	35	400	35
16.0	550	170	550	170	550	170	440	120	400	95	300	55	330	45	300	35	300	35
20.0	450	150	450	150	450	150	350	100	320	80	240	50	270	45	240	35	240	35
25.0	360	120	360	120	360	120	280	80	250	60	190	40	210	35	190	30	190	30
Standard Depth of Cut	ap	3.5DC										3.0DC						
	ae	Below ø3: 0.04DC , Above ø3 to Below ø8: 0.08DC, Above ø8: 0.1DC										0.02DC						

Endmills

Square

Radius

Ballnose

Multi-Purpose

General-Purpose

High Efficiency

Hardened Steel

Roughing

Non-Ferrous Metal

CFRP

Coated

Uncoated

SSM 2000 type

General Steel Carbon Steel Cast Iron Aluminum Alloy

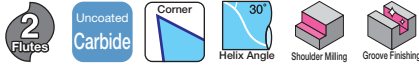
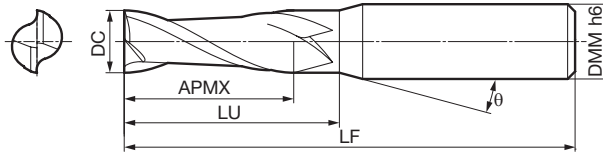

Fig 1



DC		theta	DC		Tolerance	
< ø3		10°	D ≤ 6.0	-0.010	-0.030	
≥ ø3 < ø6		15°	6.0 < D ≤ 10.0	-0.015	-0.040	
> ø6		20°	10.0 < D	-0.020	-0.050	

Body (Diameter ø0.2 to 4.6mm)

Dimensions (mm)

Cat. No.	Stock	Dia. DC	Cutting Edge Length		Overall Length LF	Shank Dia. DMM	Fig
			APMX	LU			
SSM 2002	▲	0.2	0.5	0.5	40	3	1
2003	▲	0.3	1.0	1.0	40	3	1
2004	▲	0.4	1.0	1.0	40	3	1
2005	▲	0.5	1.5	1.5	40	3	1
2006	▲	0.6	1.5	1.5	40	3	1
SSM 2007	▲	0.7	1.5	1.5	40	3	1
2008	▲	0.8	2.0	2.0	40	3	1
2009	▲	0.9	2.0	2.0	40	3	1
2010	▲	1.0	3.0	3.9	40	4	1
2011	▲	1.1	3.0	4.2	40	4	1
SSM 2012	▲	1.2	3.0	4.0	40	4	1
2013	▲	1.3	3.0	4.3	40	4	1
2014	▲	1.4	3.0	4.1	40	4	1
2015	▲	1.5	5.0	5.9	40	4	1
2016	▲	1.6	5.0	6.1	40	4	1
SSM 2017	▲	1.7	5.0	5.9	40	4	1
2018	▲	1.8	5.0	6.2	40	4	1
2019	▲	1.9	5.0	6.0	40	4	1
2020	▲	2.0	6.0	6.8	40	4	1
2021	▲	2.1	6.0	7.1	40	4	1
SSM 2022	▲	2.2	6.0	6.8	40	4	1
2023	▲	2.3	6.0	7.1	40	4	1
2024	▲	2.4	6.0	6.9	40	4	1
2025	▲	2.5	8.0	8.7	40	4	1
2026	▲	2.6	8.0	9.0	40	4	1
SSM 2027	▲	2.7	8.0	8.8	40	4	1
2028	▲	2.8	8.0	9.0	40	4	1
2029	▲	2.9	8.0	8.8	40	4	1
2030	▲	3.0	8.0	12.9	45	6	1
2031	▲	3.1	8.0	12.0	45	6	1
SSM 2032	▲	3.2	8.0	12.2	45	6	1
2033	▲	3.3	8.0	12.4	45	6	1
2034	▲	3.4	8.0	12.6	45	6	1
2035	▲	3.5	8.0	12.8	45	6	1
2036	▲	3.6	10.0	14.0	45	6	1
SSM 2037	▲	3.7	10.0	14.2	45	6	1
2038	▲	3.8	10.0	14.3	45	6	1
2039	▲	3.9	10.0	14.5	45	6	1
2040	▲	4.0	10.0	14.7	45	6	1
2041	▲	4.1	10.0	14.4	45	6	1
SSM 2042	▲	4.2	10.0	14.6	45	6	1
2043	▲	4.3	10.0	14.8	45	6	1
2044	▲	4.4	10.0	15.0	45	6	1
2045	▲	4.5	10.0	15.2	45	6	1
2046	▲	4.6	12.0	17.8	50	6	1

Grade: A1

Endmills

I

Square

Radius

Ballnose

Multi-Purpose

General-Purpose

High Efficiency

Hardened Steel

Roughing

Non-Ferrous Metal

CFRP

Coated

Uncoated

Solid Carbide Spiral Endmills

SSM 2000 type

General Steel Carbon Steel Cast Iron Aluminum Alloy

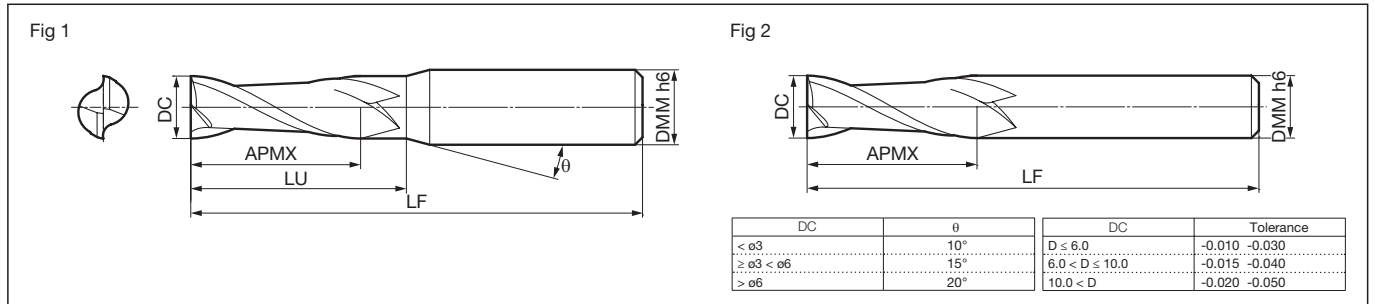
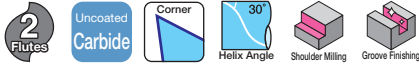

Body (Diameter ø4.7 to 9.1mm)

Dimensions (mm)

Cat. No.	Stock	Dia. DC	Cutting Edge Length APMX	Neck Length LU	Overall Length LF	Shank Dia. DMM	Fig
SSM 2047	▲	4.7	12.0	18.0	50	6	1
2048	▲	4.8	12.0	18.2	50	6	1
2049	▲	4.9	12.0	18.4	50	6	1
2050	▲	5.0	12.0	18.6	50	6	1
2051	▲	5.1	12.0	18.3	50	6	1
SSM 2052	▲	5.2	12.0	18.5	50	6	1
2053	▲	5.3	12.0	18.6	50	6	1
2054	▲	5.4	12.0	18.8	50	6	1
2055	▲	5.5	12.0	19.0	50	6	1
2056	▲	5.6	12.0	19.2	50	6	1
SSM 2057	▲	5.7	12.0	19.4	50	6	1
2058	▲	5.8	12.0	19.6	50	6	1
2059	▲	5.9	12.0	19.8	50	6	1
2060	▲	6.0	12.0	—	50	6	2
2061	▲	6.1	12.0	16.3	50	8	1
SSM 2062	▲	6.2	12.0	16.5	50	8	1
2063	▲	6.3	12.0	16.6	50	8	1
2064	▲	6.4	12.0	16.8	50	8	1
2065	▲	6.5	12.0	16.9	50	8	1
2066	▲	6.6	15.0	23.0	55	8	1
SSM 2067	▲	6.7	15.0	23.2	55	8	1
2068	▲	6.8	15.0	23.3	55	8	1
2069	▲	6.9	15.0	23.4	55	8	1
2070	▲	7.0	15.0	23.6	55	8	1
2071	▲	7.1	15.0	23.7	55	8	1
SSM 2072	▲	7.2	15.0	23.9	55	8	1
2073	▲	7.3	15.0	24.0	55	8	1
2074	▲	7.4	15.0	24.1	55	8	1
2075	▲	7.5	15.0	24.3	55	8	1
2076	▲	7.6	15.0	23.9	55	8	1
SSM 2077	▲	7.7	15.0	24.0	55	8	1
2078	▲	7.8	15.0	24.2	55	8	1
2079	▲	7.9	15.0	24.3	55	8	1
2080	▲	8.0	15.0	—	55	8	2
2081	▲	8.1	15.0	22.2	55	10	1
SSM 2082	▲	8.2	15.0	22.5	55	10	1
2083	▲	8.3	15.0	22.6	55	10	1
2084	▲	8.4	15.0	22.8	55	10	1
2085	▲	8.5	15.0	22.9	55	10	1
2086	▲	8.6	15.0	23.0	55	10	1
SSM 2087	▲	8.7	15.0	23.2	55	10	1
2088	▲	8.8	15.0	23.3	55	10	1
2089	▲	8.9	15.0	23.4	55	10	1
2090	▲	9.0	15.0	23.6	55	10	1
2091	▲	9.1	15.0	23.7	55	10	1

Grade: A1

SSM 2000 type

General Steel Carbon Steel Cast Iron Aluminum Alloy

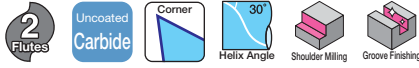

Fig 1

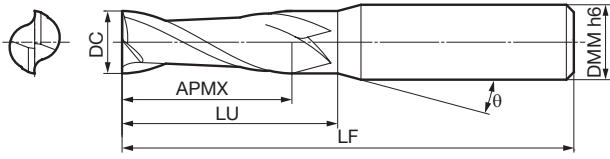
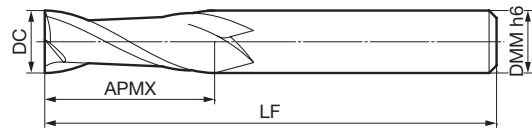

Fig 2



DC	θ	DC	Tolerance
$< \phi 3$	10°	$D \leq 6.0$	-0.010 -0.030
$\geq \phi 3 < \phi 6$	15°	$6.0 < D \leq 10.0$	-0.015 -0.040
$> \phi 6$	20°	$10.0 < D$	-0.020 -0.050

Body (Diameter $\phi 9.2$ to 30.0mm)

Dimensions (mm)

Cat. No.	Stock	Dia. DC	Cutting Edge Length APMX	Neck Length LU	Overall Length LF	Shank Dia. DMM	Fig
SSM 2092	▲	9.2	15.0	23.9	55	10	1
2093	▲	9.3	15.0	24.0	55	10	1
2094	▲	9.4	15.0	24.1	55	10	1
2095	▲	9.5	15.0	24.3	55	10	1
2096	▲	9.6	18.0	28.9	65	10	1
SSM 2097	▲	9.7	18.0	29.0	65	10	1
2098	▲	9.8	18.0	29.2	65	10	1
2099	▲	9.9	18.0	29.3	65	10	1
2100	▲	10.0	18.0	—	65	10	2
2105	▲	10.5	18.0	29.4	70	12	1
SSM 2110	▲	11.0	18.0	30.1	70	12	1
2115	▲	11.5	18.0	29.8	70	12	1
2120	▲	12.0	18.0	—	70	12	2
2125	▲	12.5	20.0	31.1	80	16	1
2130	▲	13.0	20.0	31.8	80	16	1
SSM 2135	▲	13.5	20.0	31.5	80	16	1
2140	▲	14.0	20.0	32.2	80	16	1
2145	▲	14.5	25.0	37.9	80	16	1
2150	▲	15.0	25.0	38.6	80	16	1
2155	▲	15.5	35.0	49.8	90	16	1
SSM 2160	▲	16.0	35.0	—	90	16	2
2165	▲	16.5	35.0	45.1	90	20	1
2170	▲	17.0	35.0	45.8	90	20	1
2175	▲	17.5	40.0	56	105	20	1
2180	▲	18.0	40.0	56.7	105	20	1
SSM 2185	▲	18.5	40.0	56.9	105	20	1
2190	▲	19.0	40.0	57.6	105	20	1
2195	▲	19.5	40.0	58.3	105	20	1
2200	▲	20.0	40.0	—	105	20	2
2210	▲	21.0	40.0	54.5	105	25	1
SSM 2220	▲	22.0	40.0	55.8	105	25	1
2230	▲	23.0	45.0	65.2	115	25	1
2240	▲	24.0	45.0	63.6	115	25	1
2250	▲	25.0	50.0	—	120	25	2
2300	▲	30.0	55.0	—	130	32	1

Grade: A1

Endmills

I

Square

Radius

Ballnose

Multi-Purpose

General-Purpose

High Efficiency

Hardened Steel

Roughing

Non-Ferrous Metal

CFRP

Coated

Uncoated

Solid Carbide Spiral Endmills

SSM 2000 type

Recommended Cutting Conditions

1. If the machine cannot achieve the recommended spindle speed, please use the maximum spindle speed available.
2. If cutting noise and vibration occur, please reduce the cutting conditions accordingly.

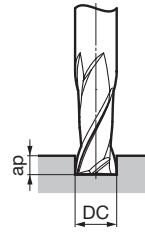

Groove Milling

Work Material	Carbon Steel / Alloy Steel (Below 30HRC)		Carbon Steel / Alloy Steel (Below 40HRC)		Carbon Steel / Alloy Steel (Below 45HRC)		Cast Iron / Special Cast Iron	
	Spindle Speed (min ⁻¹)	Feed Rate (mm/min)	Spindle Speed (min ⁻¹)	Feed Rate (mm/min)	Spindle Speed (min ⁻¹)	Feed Rate (mm/min)	Spindle Speed (min ⁻¹)	Feed Rate (mm/min)
DC (mm)								
0.2	35,000	30	35,000	20	28,000	15	35,000	30
0.6	20,000	45	16,000	30	13,000	20	26,000	80
1.0	12,000	45	9,600	35	7,800	30	15,600	150
2.0	6,000	70	4,800	35	3,900	30	7,800	165
3.0	4,000	90	3,200	35	2,600	30	5,200	170
4.0	3,000	90	2,400	35	1,950	30	3,900	170
6.0	2,000	90	1,600	35	1,300	30	2,600	210
8.0	1,500	90	1,200	35	980	30	1,950	250
10.0	1,200	90	960	35	780	30	1,560	250
12.0	1,000	90	800	35	650	30	1,300	250
16.0	750	90	600	40	490	30	970	260
20.0	600	90	480	40	390	30	780	260
25.0	480	90	380	40	310	30	620	250
30.0	400	90	320	40	260	30	520	250
Standard	ap 01 or less	0.1DC	0.1DC	0.1DC	0.1DC	0.1DC	0.1DC	0.1DC
Depth of Cut	01.1 to 02.9 ap	0.3DC	0.3DC	0.3DC	0.3DC	0.3DC	0.3DC	0.3DC
Cut	ap 03 and above	0.5DC	0.5DC	0.5DC	0.5DC	0.5DC	0.5DC	0.5DC

Endmills



Square

Radius

Ballnose

Multi-Purpose

General-Purpose

High Efficiency

Hardened Steel

Roughing

Non-Ferrous Metal

CFRP

Coated

Uncoated

SSM 4000 type

General Steel Carbon Steel Cast Iron Aluminum Alloy

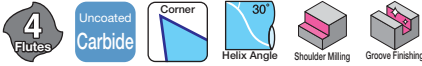

Endmills

I

Square

Radius

Ballnose

Multi-Purpose

General-Purpose

High Efficiency

Hardened Steel

Roughing

Non-Ferrous Metal

CFRP

Coated

Coated

Uncoated

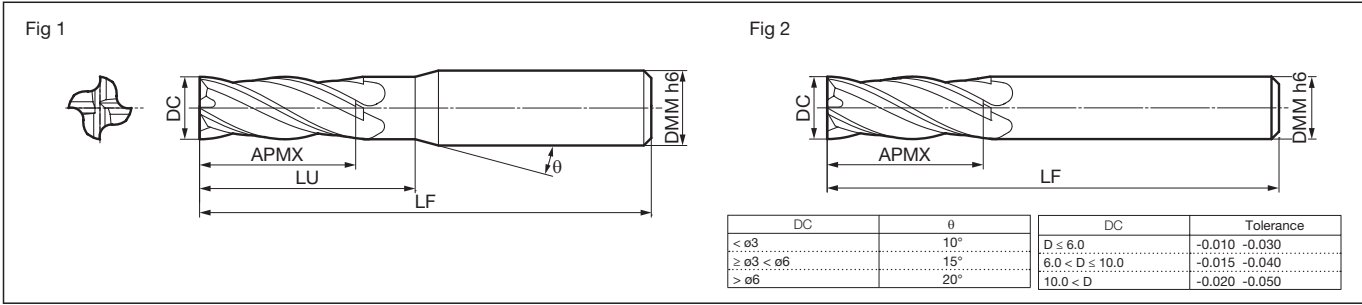

Body

Cat. No.	Stock	Dia. DC	Cutting Edge Length APMX	Neck Length LU	Overall Length LF	Dimensions (mm)	
						Shank Dia. DMM	Fig
SSM 4015	▲	1.5	5.0	5.9	40	4	1
4020	▲	2.0	6.0	6.8	40	4	1
4025	▲	2.5	8.0	8.7	40	4	1
4030	▲	3.0	8.0	11.4	45	6	1
4035	▲	3.5	8.0	11.8	45	6	1
SSM 4040	▲	4.0	10.0	13.7	45	6	1
4045	▲	4.5	10.0	14.2	45	6	1
4050	▲	5.0	12.0	17.1	50	6	1
4055	▲	5.5	12.0	17.5	50	6	1
4060	▲	6.0	12.0	—	50	6	2
SSM 4065	▲	6.5	12.0	16.9	50	8	1
4070	▲	7.0	15.0	21.1	55	8	1
4075	▲	7.5	15.0	21.3	55	8	1
4080	▲	8.0	15.0	—	55	8	2
4085	▲	8.5	15.0	21.9	55	10	1
SSM 4090	▲	9.0	15.0	22.1	55	10	1
4095	▲	9.5	15.0	22.3	55	10	1
4100	▲	10.0	18.0	—	65	10	2
4105	*	10.5	18.0	19.9	65	12	1
4110	▲	11.0	18.0	20.6	70	12	1
SSM 4120	▲	12.0	18.0	—	70	12	2
4130	▲	13.0	20.0	28.8	80	16	1
4140	▲	14.0	20.0	29.2	80	16	1
4150	▲	15.0	25.0	34.6	80	16	1
4160	▲	16.0	35.0	—	90	16	2
SSM 4170	*	17.0	35.0	42.8	90	20	1
4180	▲	18.0	40.0	51.2	105	20	1
4190	*	19.0	40.0	51.6	105	20	1
4200	▲	20.0	40.0	—	105	20	2
4210	*	21.0	40.0	52.5	105	25	1
SSM 4220	*	22.0	40.0	52.8	105	25	1
4230	*	23.0	45.0	58.2	115	25	1
4240	*	24.0	45.0	58.6	115	25	1
4250	▲	25.0	50.0	—	120	25	2

Grade: A1

▲ mark: To be replaced by a new product, made to order, or discontinued (please confirm stock availability)
 * mark: Semi-standard stock (please confirm stock availability)

Solid Carbide Spiral Endmills

SSM 4000 type

Recommended Cutting Conditions

1. If the machine cannot achieve the recommended spindle speed, please use the maximum spindle speed available.
2. If cutting noise and vibration occur, please reduce the cutting conditions accordingly.

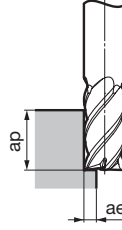

Side Milling

Work Material Cutting Conditions	Carbon Steel / Alloy Steel (Below 30HRC)		Carbon Steel / Alloy Steel (Below 40HRC)		Carbon Steel / Alloy Steel (Below 45HRC)		Cast Iron Special Cast Iron	
	Spindle Speed (min ⁻¹)	Feed Rate (mm/min)	Spindle Speed (min ⁻¹)	Feed Rate (mm/min)	Spindle Speed (min ⁻¹)	Feed Rate (mm/min)	Spindle Speed (min ⁻¹)	Feed Rate (mm/min)
DC (mm)								
1.5	7,600	250	7,000	100	5,600	85	9,800	550
2.0	5,720	250	5,250	100	4,200	85	7,350	550
3.0	3,800	250	3,500	100	2,800	80	4,900	550
6.0	1,900	280	1,750	100	1,400	80	2,450	650
8.0	1,430	280	1,310	100	1,050	80	1,840	650
10.0	1,140	280	1,050	100	840	80	1,470	670
12.0	950	280	880	100	700	80	1,230	680
16.0	710	320	660	100	525	80	920	830
20.0	570	300	530	95	420	80	740	920
25.0	460	260	420	80	335	65	590	740
Standard Depth of Cut	ap	1.5DC	1.5DC	1.5DC	1.5DC	1.5DC	1.5DC	1.5DC
	ae	0.1DC	0.1DC	0.1DC	0.1DC	0.1DC	0.1DC	0.1DC

- Endmills
- I
- Square
- Radius
- Ballnose
- Multi-Purpose
- General-Purpose
- High Efficiency
- Hardened Steel
- Roughing
- Non-Ferrous Metal
- CFRP
- Coated
- Uncoated

GSV 4000-2.5D type

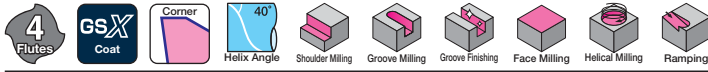

Endmills

I

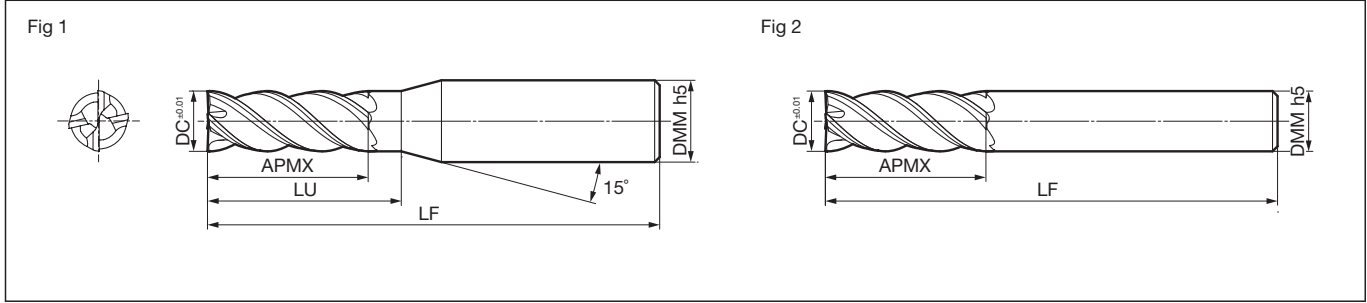

Body

Dimensions (mm)

Cat. No.	Stock	Dia. DC	Cutting Edge Length APMX	Neck Length LU	Overall Length LF	Shank Dia. DMM	Fig
GSV 4020-2.5D	●	2.0	5	6.5	50	4	1
4030-2.5D	●	3.0	8	9.5	50	6	1
4040-2.5D	●	4.0	10	11.5	50	6	1
4050-2.5D	●	5.0	13	14.5	60	6	1
4060-2.5D	●	6.0	15	—	60	6	2
GSV 4070-2.5D	●	7.0	18	20.0	70	8	1
4080-2.5D	●	8.0	20	—	80	8	2
4090-2.5D	●	9.0	23	25.0	90	10	1
4100-2.5D	●	10.0	25	—	90	10	2
4110-2.5D	●	11.0	28	30.5	90	12	1
GSV 4120-2.5D	●	12.0	30	—	90	12	2
4140-2.5D	●	14.0	35	37.5	110	16	1
4150-2.5D	●	15.0	38	41.0	110	16	1
4160-2.5D	●	16.0	40	—	115	16	2
4180-2.5D	●	18.0	45	48.0	120	20	1
GSV 4200-2.5D	●	20.0	50	—	125	20	2
4250-2.5D	●	25.0	63	—	140	25	2

Grade: ACF20

Identification Code

GSV 4 120 - 2.5D

Series Code No. of Flutes Dia. Cutting Edge Length

Square

Radius

Ballnose

Multi-Purpose

General-Purpose

High Efficiency

Hardened Steel

Roughing

Non-Ferrous Metal

CFRP

Coated

Uncoated

GSV 4000-2.5D type

Recommended Cutting Conditions

1. For stable machining performance use rigid, high-precision machines and holders.
2. Use air blow when dry machining.
3. Use wet machining for stainless steel, heat-resistant alloy, and titanium alloy applications.
4. If the machine cannot achieve the recommended spindle speed, please use the maximum spindle speed available.

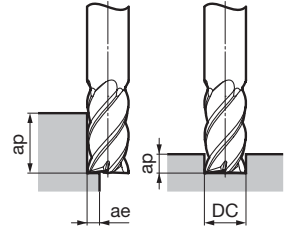

Side Milling

Work Material Cutting Conditions	Carbon Steel, Cast Iron SS, SC, FC (150 to 250HB)		Alloy Steel SCM (25 to 35HRC)		Tempered Steel / Hardened Steel NAK, HPM (40 to 50HRC)		Stainless Steel SUS304,SUS316		Titanium Alloy		
	DC (mm)	Spindle Speed (min ⁻¹)	Feed Rate (mm/min)	Spindle Speed (min ⁻¹)	Feed Rate (mm/min)	Spindle Speed (min ⁻¹)	Feed Rate (mm/min)	Spindle Speed (min ⁻¹)	Feed Rate (mm/min)	Spindle Speed (min ⁻¹)	Feed Rate (mm/min)
2.0	13,000	1,000	10,000	800	8,000	700	10,000	580	5,000	200	
4.0	9,600	1,200	8,000	1,000	6,000	800	5,500	650	3,000	230	
6.0	6,800	1,500	5,600	1,200	4,200	900	3,800	680	2,100	240	
8.0	5,200	1,600	4,400	1,300	3,200	950	2,800	650	1,600	250	
10.0	4,200	1,500	3,500	1,200	2,600	800	2,300	600	1,300	210	
12.0	3,500	1,400	3,000	1,200	2,200	700	1,900	550	1,100	180	
14.0	3,000	1,200	2,600	1,100	1,800	600	1,600	500	900	150	
16.0	2,700	1,100	2,200	1,000	1,600	600	1,400	480	760	130	
18.0	2,400	1,000	2,000	900	1,400	570	1,300	450	680	120	
20.0	2,200	900	1,700	800	1,200	550	1,100	400	600	100	
25.0	1,700	680	1,400	630	1,000	450	890	310	480	82	
Standard Depth of Cut	ap	1.5DC									
	ae	0.2DC		0.05DC		0.1DC		0.05DC			

Groove Milling

Work Material Cutting Conditions	Carbon Steel, Cast Iron SS, SC, FC (150 to 250HB)		Alloy Steel SCM (25 to 35HRC)		Tempered Steel / Hardened Steel NAK, HPM (40 to 50HRC)		Stainless Steel SUS304,SUS316		Titanium Alloy		
	DC (mm)	Spindle Speed (min ⁻¹)	Feed Rate (mm/min)	Spindle Speed (min ⁻¹)	Feed Rate (mm/min)	Spindle Speed (min ⁻¹)	Feed Rate (mm/min)	Spindle Speed (min ⁻¹)	Feed Rate (mm/min)	Spindle Speed (min ⁻¹)	Feed Rate (mm/min)
2.0	13,000	750	10,000	550	8,400	500	6,500	300	4,000	140	
4.0	8,200	800	6,000	600	5,200	500	4,000	330	2,000	130	
6.0	6,100	1,100	4,000	600	3,500	580	2,700	350	1,350	150	
8.0	4,600	1,000	3,000	580	2,600	570	2,000	330	1,000	140	
10.0	3,600	1,000	2,400	550	2,100	510	1,600	200	800	130	
12.0	3,100	920	2,000	500	1,700	450	1,300	280	660	110	
14.0	2,600	750	1,700	450	1,500	400	1,100	250	570	100	
16.0	2,300	670	1,500	420	1,300	350	1,000	230	500	90	
18.0	2,000	620	1,300	380	1,100	330	900	200	430	80	
20.0	1,900	600	1,200	360	1,000	320	800	180	380	70	
25.0	1,500	470	1,000	300	790	250	640	140	300	55	
Standard Depth of Cut	ap	0.8DC		0.16DC		0.4DC		0.16DC			

Endmills

I

Square

Radius

Ballnose

Multi-Purpose

General-Purpose

High Efficiency

Hardened Steel

Roughing

Non-Ferrous Metal

CFRP

Coated

Uncoated

GSXVL 4000-2.5D type

- General Steel
- Carbon Steel
- Alloy Steel
- Pre-hardened Steel
- Tempered Steel / Die Steel
- Hardened Steel 45 to 55HRC
- Hardened Steel 55 to 60HRC
- Stainless Steel
- Ti Alloy / Heat Resistant Alloy
- Cast Iron

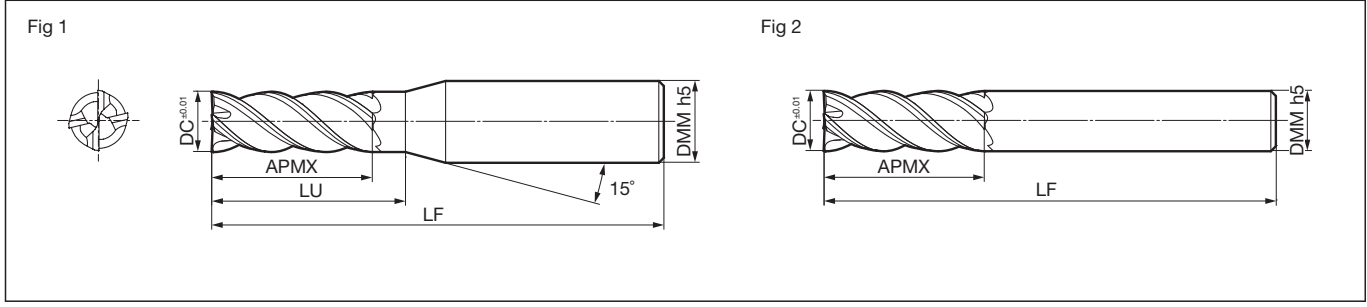
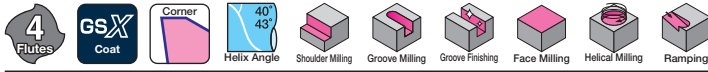

Body

Dimensions (mm)

Cat. No.	Stock	Dia. DC	Cutting Edge Length APMX	Neck Length LU	Overall Length LF	Shank Dia. DMM	Fig
GSXVL 4020-2.5D	●	2.0	5	6.5	50	4	1
4030-2.5D	●	3.0	8	9.5	50	6	1
4040-2.5D	●	4.0	10	11.5	50	6	1
4050-2.5D	●	5.0	13	14.5	60	6	1
4060-2.5D	●	6.0	15	—	60	6	2
GSXVL 4070-2.5D	●	7.0	18	20.0	70	8	1
4080-2.5D	●	8.0	20	—	80	8	2
4090-2.5D	●	9.0	23	25.0	90	10	1
4100-2.5D	●	10.0	25	—	90	10	2
4110-2.5D	●	11.0	28	30.5	90	12	1
GSXVL 4120-2.5D	●	12.0	30	—	90	12	2
4140-2.5D	●	14.0	35	37.5	110	16	1
4150-2.5D	●	15.0	38	41.0	110	16	1
4160-2.5D	●	16.0	40	—	115	16	2
4180-2.5D	●	18.0	45	48.0	120	20	1
GSXVL 4200-2.5D	●	20.0	50	—	125	20	2
4250-2.5D	●	25.0	63	—	140	25	2

Grade: ACF20

Identification Code

GSXVL 4 020 - 2.5D

Series Code No. of Flutes Dia. Cutting Edge Length

Endmills

I

Square

Radius

Ballnose

Multi-Purpose

General-Purpose

High Efficiency

Hardened Steel

Roughing

Non-Ferrous Metal

CFRP

Coated

Uncoated



For the regrinding procedure, please download the details from our website.
https://www.sumitool.com/en/products/cutting-tools/endmills/pdf/gsxvl-regrinding_en.pdf

GSXVL 4000-2.5D type

Recommended Cutting Conditions

1. For stable machining performance use rigid, high-precision machines and holders.
2. Use air blow when dry machining.
3. Use wet machining for stainless steel, heat-resistant alloy, and titanium alloy applications.
4. If the machine cannot achieve the recommended spindle speed, please use the maximum spindle speed available.

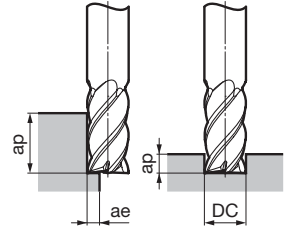

Side Milling

Work Material Cutting Conditions	Carbon Steel, Cast Iron SS, SC, FC (150 to 250HB)		Alloy Steel SCM (25 to 35HRC)		Tempered Steel / Hardened Steel NAK, HPM (40 to 50HRC)		Stainless Steel SUS304, SUS316		Titanium Alloy		
	DC (mm)	Spindle Speed (min ⁻¹)	Feed Rate (mm/min)	Spindle Speed (min ⁻¹)	Feed Rate (mm/min)	Spindle Speed (min ⁻¹)	Feed Rate (mm/min)	Spindle Speed (min ⁻¹)	Feed Rate (mm/min)	Spindle Speed (min ⁻¹)	Feed Rate (mm/min)
2.0	13,000	1,000	10,000	800	8,000	700	10,000	580	5,000	200	
4.0	9,600	1,200	8,000	1,000	6,000	800	5,500	650	3,000	230	
6.0	6,800	1,500	5,600	1,200	4,200	900	3,800	680	2,100	240	
8.0	5,200	1,600	4,400	1,300	3,200	950	2,800	650	1,600	250	
10.0	4,200	1,500	3,500	1,200	2,600	800	2,300	600	1,300	210	
12.0	3,500	1,400	3,000	1,200	2,200	700	1,900	550	1,100	180	
14.0	3,000	1,200	2,600	1,100	1,800	600	1,600	500	900	150	
16.0	2,700	1,100	2,200	1,000	1,600	600	1,400	480	760	130	
18.0	2,400	1,000	2,000	900	1,400	570	1,300	450	680	120	
20.0	2,200	900	1,700	800	1,200	550	1,100	400	600	100	
25.0	1,700	680	1,400	630	1,000	450	890	310	480	82	
Standard Depth of Cut	ap	1.5DC									
	ae	0.2DC		0.05DC		0.1DC		0.05DC			

Groove Milling

Work Material Cutting Conditions	Carbon Steel, Cast Iron SS, SC, FC (150 to 250HB)		Alloy Steel SCM (25 to 35HRC)		Tempered Steel / Hardened Steel NAK, HPM (40 to 50HRC)		Stainless Steel SUS304, SUS316		Titanium Alloy		
	DC (mm)	Spindle Speed (min ⁻¹)	Feed Rate (mm/min)	Spindle Speed (min ⁻¹)	Feed Rate (mm/min)	Spindle Speed (min ⁻¹)	Feed Rate (mm/min)	Spindle Speed (min ⁻¹)	Feed Rate (mm/min)	Spindle Speed (min ⁻¹)	Feed Rate (mm/min)
2.0	13,000	750	10,000	550	8,400	500	6,500	300	4,000	140	
4.0	8,200	800	6,000	600	5,200	500	4,000	330	2,000	130	
6.0	6,100	1,100	4,000	600	3,500	580	2,700	350	1,350	150	
8.0	4,600	1,000	3,000	580	2,600	570	2,000	330	1,000	140	
10.0	3,600	1,000	2,400	550	2,100	510	1,600	200	800	130	
12.0	3,100	920	2,000	500	1,700	450	1,300	280	660	110	
14.0	2,600	750	1,700	450	1,500	400	1,100	250	570	100	
16.0	2,300	670	1,500	420	1,300	350	1,000	230	500	90	
18.0	2,000	620	1,300	380	1,100	330	900	200	430	80	
20.0	1,900	600	1,200	360	1,000	320	800	180	380	70	
25.0	1,500	470	1,000	300	790	250	640	140	300	55	
Standard Depth of Cut	ap	1.0DC		0.2DC		0.5DC		0.2DC			

Endmills

1

Square

Radius

Ballnose

Multi-Purpose

General-Purpose

High Efficiency

Hardened Steel

Roughing

Non-Ferrous Metal

CFRP

Coated

Uncoated

SSUP 4000ZX type

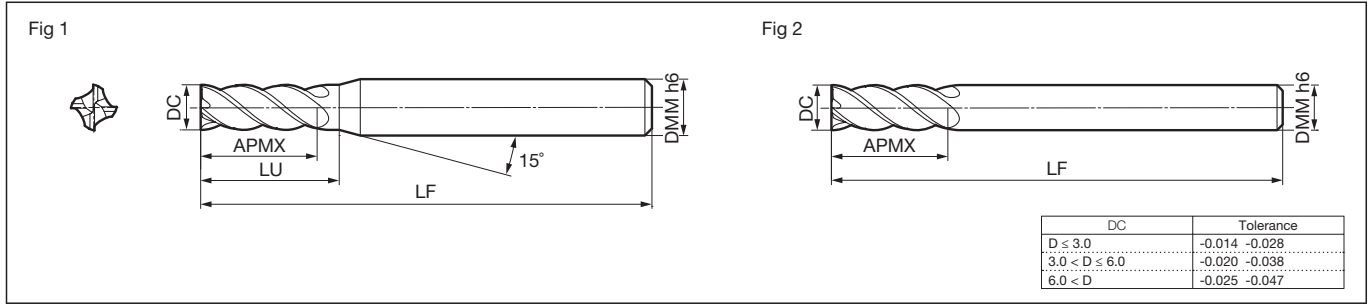
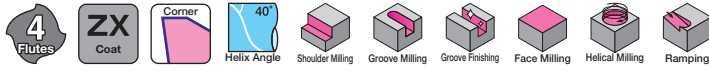

Body

Dimensions (mm)

Cat. No.	Stock	Dia. DC	Cutting Edge Length APMX	Neck Length LU	Overall Length LF	Shank Dia. DMM	Fig
SSUP 4020ZX	●	2.0	6.0	7.0	50	4	1
4030ZX	●	3.0	8.0	9.5	50	6	1
4040ZX	●	4.0	11.0	12.5	50	6	1
4050ZX	●	5.0	13.0	14.5	60	6	1
4060ZX	●	6.0	13.0	—	60	6	2
SSUP 4070ZX	●	7.0	16.0	18.0	70	8	1
4080ZX	●	8.0	19.0	—	80	8	2
4090ZX	●	9.0	19.0	21.5	90	10	1
4100ZX	●	10.0	22.0	—	90	10	2
4110ZX	●	11.0	22.0	24.5	90	12	1
SSUP 4120ZX	●	12.0	26.0	—	90	12	2
4140ZX	●	14.0	26.0	28.5	110	16	1
4150ZX	●	15.0	26.0	28.5	110	16	1
4160ZX	●	16.0	32.0	—	115	16	2
4180ZX	●	18.0	32.0	34.5	120	20	1
SSUP 4200ZX	●	20.0	38.0	—	125	20	2

Grade: ACZ50M

Recommended Cutting Conditions

- For Groove milling of stainless steel, use 60% of the recommended spindle speed and 40% of the recommended feed rate. (*)
- If cutting noise and vibration occur, please reduce the cutting conditions accordingly.

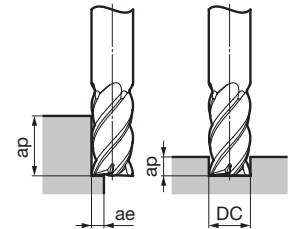

Side Milling and Groove Milling

Work Material / Cutting Conditions	Carbon Steel, Cast Iron SS, SC, FC (150 to 250HB)		Alloy Steel SCM (25 to 35HRC)		Tempered Steel / Hardened Steel NAK, HPM (40 to 50HRC)		Stainless Steel (*)		Heat-Resistant Alloy Titanium Alloy (20 to 45HRC)		
	DC (mm)	Spindle Speed (min ⁻¹)	Feed Rate (mm/min)	Spindle Speed (min ⁻¹)	Feed Rate (mm/min)	Spindle Speed (min ⁻¹)	Feed Rate (mm/min)	Spindle Speed (min ⁻¹)	Feed Rate (mm/min)	Spindle Speed (min ⁻¹)	Feed Rate (mm/min)
2.0	9,000	720	6,000	430	4,000	320	5,500	320	2,600	120	
4.0	6,600	800	4,500	450	3,000	380	4,000	320	2,000	120	
6.0	4,800	960	3,000	480	2,500	380	3,000	480	1,200	120	
8.0	3,600	1,000	2,200	610	2,000	400	2,000	520	1,000	140	
10.0	2,800	1,000	1,800	610	1,500	400	1,700	550	800	160	
12.0	2,400	950	1,500	550	1,200	380	1,500	500	700	140	
14.0	2,200	880	1,300	490	1,000	360	1,200	430	600	130	
16.0	1,800	650	1,100	420	800	300	1,000	360	500	120	
18.0	1,600	580	1,000	360	750	270	900	340	450	110	
20.0	1,400	500	900	330	700	250	820	300	400	100	
Side Milling	ap	1.5DC									
	ae	0.1DC		0.05DC		0.1DC		0.05DC			
Groove Milling	ap	1.0DC		0.2DC		0.3DC		0.2DC			

SSUPR 4000ZX type

General Steel Carbon Steel Alloy Steel Pre-hardened Steel Tempered Steel / Die Steel Hardened Steel 45 to 55HRC Hardened Steel 55 to 60HRC Stainless Steel Ti/Alloy / Heat Resistant Alloy Cast Iron

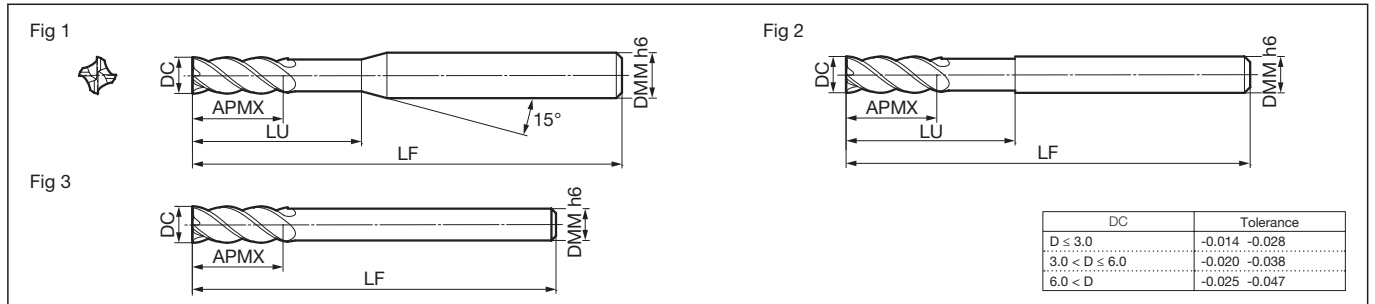

Body

Cat. No.	Stock	Dimensions (mm)						Fig
		Dia. DC	Cutting Edge Length APMX	Neck Length LU	Overall Length LF	Shank Dia. DMM		
SSUPR 4030ZX	●	3.0	4.5	12	60	6	1	
4040ZX	●	4.0	6.0	16	60	6	1	
4050ZX	●	5.0	7.5	20	60	6	1	
4060ZX	●	6.0	9.0	24	60	6	2	
4070ZX	●	7.0	10.5	—	80	6	3	
SSUPR 4080ZX	●	8.0	12.0	34	80	8	2	
4090ZX	●	9.0	13.5	—	90	8	3	
4100ZX	●	10.0	15.0	42	100	10	2	
4110ZX	●	11.0	16.5	—	120	10	3	
4120ZX	●	12.0	18.0	50	120	12	2	
SSUPR 4130ZX	●	13.0	19.5	—	130	12	3	
4160ZX	●	16.0	24.0	66	160	16	2	
4170ZX	●	17.0	25.5	—	170	16	3	
4200ZX	●	20.0	30.0	82	200	20	2	

Grade: ACZ50M

Recommended Cutting Conditions

- The conditions recommended are for endmills with standard overhang lengths of 4xD. For overhangs of 5xD or more, please use 70% (max) of recommended conditions.
- If cutting noise and vibration occur, please reduce the cutting conditions accordingly.

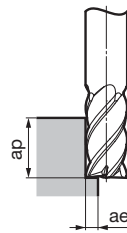

Side Milling

Work Material / Cutting Conditions	Carbon Steel, Cast Iron (150 to 250HB)		Alloy Steel SCM (25 to 35HRC)		Tempered Steel / Hardened Steel NAK, HPM (40 to 50HRC)		Stainless Steel		Heat-Resistant Alloy Titanium Alloy (20 to 45HRC)		
	Spindle Speed (min ⁻¹)	Feed Rate (mm/min)	Spindle Speed (min ⁻¹)	Feed Rate (mm/min)	Spindle Speed (min ⁻¹)	Feed Rate (mm/min)	Spindle Speed (min ⁻¹)	Feed Rate (mm/min)	Spindle Speed (min ⁻¹)	Feed Rate (mm/min)	
DC (mm)											
3.0	9,000	600	5,300	400	3,100	200	4,200	350	2,600	160	
4.0	6,600	600	4,000	400	2,400	200	3,200	350	2,000	160	
6.0	4,200	600	2,600	400	1,600	200	2,100	350	1,300	160	
8.0	3,200	650	2,000	450	1,200	200	1,600	350	1,000	160	
10.0	2,500	650	1,600	450	950	200	1,200	400	800	180	
12.0	2,100	650	1,300	450	800	200	1,000	400	650	180	
13.0	1,900	650	1,200	450	700	200	950	400	600	180	
16.0	1,600	650	1,000	400	600	200	800	350	500	160	
17.0	1,500	600	900	400	550	200	750	350	450	160	
20.0	1,200	600	800	400	500	200	650	350	400	160	
Standard Depth of Cut	ap	1.2DC									
	ae	0.1DC		0.05DC		0.1DC		0.05DC			

Endmills
I
Square
Radius
Ballnose
Multi-Purpose
General-Purpose
High Efficiency
Hardened Steel
Roughing
Non-Ferrous Metal
CFRP
Coated
Uncoated

GSH 4000SF type



Fig 1

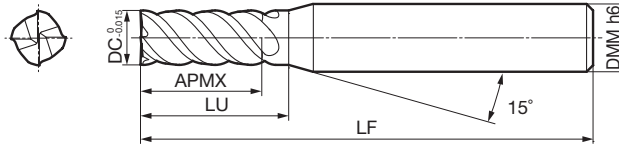

Body (4 Flutes)

Dimensions (mm)

Cat. No.	Stock	Dia. DC	Cutting Edge Length APMX	Neck Length LU	Overall Length LF	Shank Dia. DMM	Fig
GSH 4010SF	●	1.0	3.0	4.0	50	6	1
4015SF	●	1.5	4.0	5.0	50	6	1
4020SF	●	2.0	6.0	7.0	50	6	1

Grade: ACF07C

Recommended Cutting Conditions

1. If the machine cannot achieve the recommended spindle speed, please use the maximum spindle speed available.
2. If cutting noise and vibration occur, please reduce the cutting conditions accordingly.

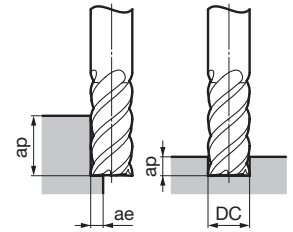

Side Milling and Groove Milling

Work Material / Cutting Conditions	Low Hardened Steel Carbon Steel, Alloy Steel (Up to 35HRC)		Medium Hardened Steel Pre-hardened Steel, Die Steel (35 to 45HRC)		Hardened Steel SKD61 (45 to 55HRC)		Hardened Steel SKD11 (55 to 60HRC)		Hardened Steel SKH51 (60 to 65HRC)		Hardened Steel SKH55 (65HRC up)		
	DC (mm)	Spindle Speed (min ⁻¹)	Feed Rate (mm/min)	Spindle Speed (min ⁻¹)	Feed Rate (mm/min)	Spindle Speed (min ⁻¹)	Feed Rate (mm/min)	Spindle Speed (min ⁻¹)	Feed Rate (mm/min)	Spindle Speed (min ⁻¹)	Feed Rate (mm/min)	Spindle Speed (min ⁻¹)	Feed Rate (mm/min)
Side Milling	ap	1 to 1.5DC		1 to 1.5DC		1 to 1.5DC		1 to 1.5DC		1 to 1.5DC		1 to 1.5DC	
Groove Milling	ae	0.1DC		0.1DC		0.05DC		0.05DC		0.02DC		0.02DC	
	ap	0.1DC		0.1DC		0.05DC		0.05DC		Up to 0.05DC Max. 0.5mm		Up to 0.05DC Max. 0.5mm	

Side Milling (Using High Speed Machining Centre)

Work Material / Cutting Conditions	Low Hardened Steel Carbon Steel, Alloy Steel (Up to 35HRC)		Medium Hardened Steel Pre-hardened Steel, Die Steel (35 to 45HRC)		Hardened Steel SKD61 (45 to 55HRC)		Hardened Steel SKD11 (55 to 60HRC)		Hardened Steel SKH51 (60 to 65HRC)		
	DC (mm)	Spindle Speed (min ⁻¹)	Feed Rate (mm/min)	Spindle Speed (min ⁻¹)	Feed Rate (mm/min)	Spindle Speed (min ⁻¹)	Feed Rate (mm/min)	Spindle Speed (min ⁻¹)	Feed Rate (mm/min)	Spindle Speed (min ⁻¹)	Feed Rate (mm/min)
Standard	ap	1 to 1.5DC		1 to 1.5DC		1 to 1.5DC		1 to 1.5DC		1 to 1.5DC	
Depth of Cut	ae	0.1DC		0.05DC		0.05DC		0.02DC		0.01DC	

Endmills

I

Square

Radius

Ballnose

Multi-Purpose

General-Purpose

High Efficiency

Hardened Steel

Roughing

Non-Ferrous Metal

CFRP

Coated

Uncoated

GSH 6000SF type

General Steel Carbon Steel Alloy Steel Pre-hardened Steel Tempered Steel / Die Steel Hardened Steel 45 to 55HRC Hardened Steel 55 to 60HRC

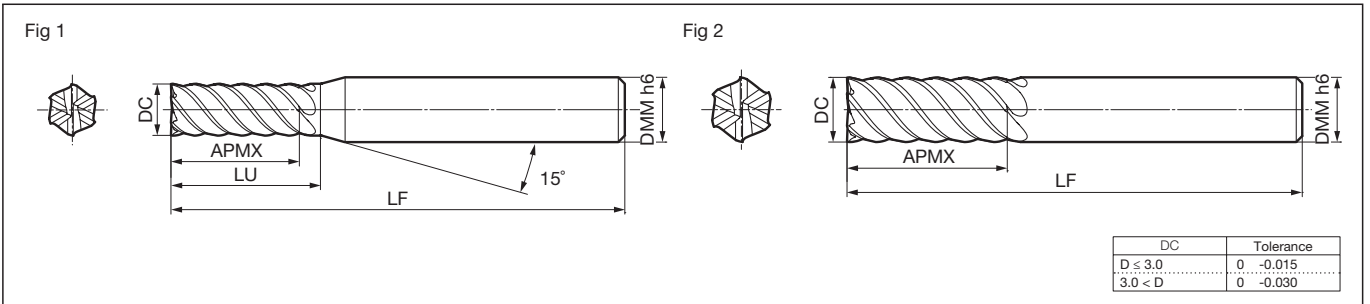

Body (6 Flutes)

Cat. No.	Stock	Dimensions (mm)						Fig
		Dia. DC	Cutting Edge Length APMX	Neck Length LU	Overall Length LF	Shank Dia. DMM		
GSH 6030SF	●	3.0	8.0	9.0	50	6	1	
6040SF	●	4.0	11.0	12.0	50	6	1	
6050SF	●	5.0	13.0	14.0	50	6	1	
6060SF	●	6.0	13.0	—	50	6	2	
6080SF	●	8.0	19.0	—	60	8	2	
GSH 6100SF	●	10.0	22.0	—	70	10	2	
6120SF	●	12.0	26.0	—	75	12	2	

Grade: ACF07C

Recommended Cutting Conditions

1. If the machine cannot achieve the recommended spindle speed, please use the maximum spindle speed available.
2. If cutting noise and vibration occur, please reduce the cutting conditions accordingly.

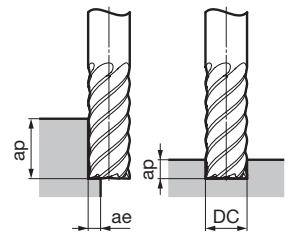

Side Milling and Groove Milling

Work Material	Low Hardened Steel Carbon Steel, Alloy Steel (Up to 35HRC)		Medium Hardened Steel Pre-hardened Steel, Die Steel (35 to 45HRC)		Hardened Steel SKD61 (45 to 55HRC)		Hardened Steel SKD11 (55 to 60HRC)		Hardened Steel SKH51 (60 to 65HRC)		Hardened Steel SKH55 (65HRC up)		
	DC (mm)	Spindle Speed (min ⁻¹)	Feed Rate (mm/min)	Spindle Speed (min ⁻¹)	Feed Rate (mm/min)	Spindle Speed (min ⁻¹)	Feed Rate (mm/min)	Spindle Speed (min ⁻¹)	Feed Rate (mm/min)	Spindle Speed (min ⁻¹)	Feed Rate (mm/min)	Spindle Speed (min ⁻¹)	Feed Rate (mm/min)
3.0	15,000	2,150	13,400	1,540	10,400	1,050	8,200	650	7,400	540	5,200	380	
4.0	11,200	2,400	10,000	1,740	7,800	1,180	6,100	730	5,600	600	3,900	420	
5.0	9,000	2,700	8,000	1,930	6,200	1,300	4,900	810	4,400	670	3,100	470	
6.0	7,500	2,700	6,700	1,930	5,200	1,300	4,100	810	3,700	670	2,600	470	
8.0	5,600	2,700	5,000	1,930	3,900	1,300	3,050	810	2,800	670	1,950	470	
10.0	4,500	2,700	4,000	1,930	3,100	1,300	2,450	810	2,200	670	1,550	470	
12.0	3,750	2,700	3,350	1,930	2,600	1,300	2,050	810	1,850	670	1,300	470	
Side Milling	ap	1 to 1.5DC		1 to 1.5DC		1 to 1.5DC		1 to 1.5DC		1 to 1.5DC		1 to 1.5DC	
Milling	ae	0.1DC		0.1DC		0.05DC		0.05DC		0.02DC		0.02DC	
Groove Milling	ap	0.1DC		0.1DC		0.05DC		0.05DC		Up to 0.05DC Max. 0.5mm		Up to 0.05DC Max. 0.5mm	

Side Milling (Using High Speed Machining Centre)

Work Material	Low Hardened Steel Carbon Steel, Alloy Steel (Up to 35HRC)		Medium Hardened Steel Pre-hardened Steel, Die Steel (35 to 45HRC)		Hardened Steel SKD61 (45 to 55HRC)		Hardened Steel SKD11 (55 to 60HRC)		Hardened Steel SKH51 (60 to 65HRC)		
	DC (mm)	Spindle Speed (min ⁻¹)	Feed Rate (mm/min)	Spindle Speed (min ⁻¹)	Feed Rate (mm/min)	Spindle Speed (min ⁻¹)	Feed Rate (mm/min)	Spindle Speed (min ⁻¹)	Feed Rate (mm/min)	Spindle Speed (min ⁻¹)	Feed Rate (mm/min)
3.0	32,000	4,900	32,000	4,900	32,000	4,900	24,000	2,740	16,000	1,700	
4.0	24,000	5,200	24,000	5,200	24,000	5,200	18,000	2,900	12,000	1,800	
5.0	19,200	5,800	19,200	5,800	19,200	5,800	14,300	3,200	9,600	2,000	
6.0	16,000	5,800	16,000	5,800	16,000	5,800	12,000	3,200	8,000	2,000	
8.0	12,000	5,800	12,000	5,800	12,000	5,800	9,000	3,200	6,000	2,000	
10.0	9,600	5,800	9,600	5,800	9,600	5,800	7,200	3,200	4,800	2,000	
12.0	8,000	5,800	8,000	5,800	8,000	5,800	6,000	3,200	4,000	2,000	
Standard Depth of Cut	ap	1 to 1.5DC		1 to 1.5DC		1 to 1.5DC		1 to 1.5DC		1 to 1.5DC	
	ae	0.1DC		0.05DC		0.05DC		0.02DC		0.01DC	

Endmills

I

Square

Radius

Ballnose

Multi-Purpose

General-Purpose

High Efficiency

Hardened Steel

Roughing

Non-Ferrous Metal

CFRP

Coated

Uncoated

GSH 8000SF type

General Steel Carbon Steel Alloy Steel Pre-hardened Steel Tempered Steel / Die Steel Hardened Steel 45 to 55HRC Hardened Steel 55 to 60HRC



Fig 1

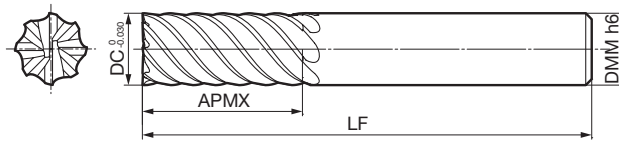

Body (8 Flutes)

Dimensions (mm)

Cat. No.	Stock	Dia. DC	Cutting Edge Length APMX	Overall Length LF	Shank Dia. DMM	Fig
GSH 8160SF	●	16.0	32.0	90	16	1
8200SF	●	20.0	38.0	100	20	1

Grade: ACF07C

Recommended Cutting Conditions

1. If the machine cannot achieve the recommended spindle speed, please use the maximum spindle speed available.
2. If cutting noise and vibration occur, please reduce the cutting conditions accordingly.

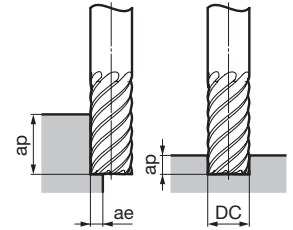

Side Milling and Groove Milling

Work Material / Cutting Conditions	Low Hardened Steel Carbon Steel, Alloy Steel (Up to 35HRC)		Medium Hardened Steel Pre-hardened Steel, Die Steel (35 to 45HRC)		Hardened Steel SKD61 (45 to 55HRC)		Hardened Steel SKD11 (55 to 60HRC)		Hardened Steel SKH51 (60 to 65HRC)		Hardened Steel SKH55 (65HRC up)		
	Spindle Speed (min ⁻¹)	Feed Rate (mm/min)	Spindle Speed (min ⁻¹)	Feed Rate (mm/min)	Spindle Speed (min ⁻¹)	Feed Rate (mm/min)	Spindle Speed (min ⁻¹)	Feed Rate (mm/min)	Spindle Speed (min ⁻¹)	Feed Rate (mm/min)	Spindle Speed (min ⁻¹)	Feed Rate (mm/min)	
DC (mm)													
16.0	2,800	2,500	2,500	1,800	1,950	1,220	1,530	760	1,400	630	980	440	
20.0	2,250	2,100	2,000	1,540	1,550	1,050	1,230	650	1,100	540	780	380	
Side Milling	ap	1 to 1.5DC		1 to 1.5DC		1 to 1.5DC		1 to 1.5DC		1 to 1.5DC		1 to 1.5DC	
	ae	0.1DC		0.1DC		0.05DC		0.05DC		0.02DC		0.02DC	
Groove Milling	ap	0.1DC		0.1DC		0.05DC		0.05DC		Up to 0.05DC Max. 0.5mm		Up to 0.05DC Max. 0.5mm	

Side Milling (Using High Speed Machining Centre)

Work Material / Cutting Conditions	Low Hardened Steel Carbon Steel, Alloy Steel (Up to 35HRC)		Medium Hardened Steel Pre-hardened Steel, Die Steel (35 to 45HRC)		Hardened Steel SKD61 (45 to 55HRC)		Hardened Steel SKD11 (55 to 60HRC)		Hardened Steel SKH51 (60 to 65HRC)		
	Spindle Speed (min ⁻¹)	Feed Rate (mm/min)	Spindle Speed (min ⁻¹)	Feed Rate (mm/min)	Spindle Speed (min ⁻¹)	Feed Rate (mm/min)	Spindle Speed (min ⁻¹)	Feed Rate (mm/min)	Spindle Speed (min ⁻¹)	Feed Rate (mm/min)	
DC (mm)											
16.0	6,000	5,400	6,000	5,400	6,000	5,400	4,500	3,000	3,000	1,900	
20.0	4,800	4,600	4,800	4,600	4,800	4,600	3,600	2,580	2,400	1,600	
Standard Depth of Cut	ap	1 to 1.5DC		1 to 1.5DC		1 to 1.5DC		1 to 1.5DC		1 to 1.5DC	
	ae	0.1DC		0.05DC		0.05DC		0.02DC		0.01DC	

Endmills

I

Square

Radius

Ballnose

Multi-Purpose

General-Purpose

High Efficiency

Hardened Steel

Roughing

Non-Ferrous Metal

CFRP

Coated

Uncoated

HHM 4000ZX type

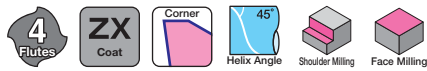
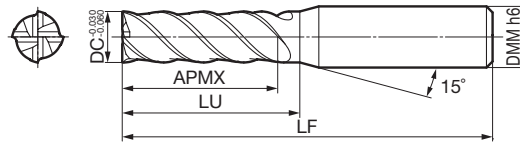

Fig 1



Body (4 Flutes)

Dimensions (mm)

Cat. No.	Stock	Dia. DC	Cutting Edge Length APMX	Neck Length LU	Overall Length LF	Shank Dia. DMM	Fig
HHM 4030ZX	●	3.0	8.0	11.0	50	6	1
4040ZX	●	4.0	10.0	13.0	50	6	1
4050ZX	●	5.0	12.0	15.0	50	6	1

Grade: ACZ10M

Recommended Cutting Conditions

1. If the machine cannot achieve the recommended spindle speed, please use the maximum spindle speed available.
2. If cutting noise and vibration occur, please reduce the cutting conditions accordingly.

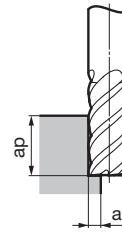

Side Milling

Work Material Cutting Conditions	Carbon Steel / Alloy Steel (Below 25HRC)		Carbon Steel / Alloy Steel (Below 45HRC)		Hardened Steel (Below 65HRC)		Cast Iron Special Cast Iron	
	Spindle Speed (min ⁻¹)	Feed Rate (mm/min)	Spindle Speed (min ⁻¹)	Feed Rate (mm/min)	Spindle Speed (min ⁻¹)	Feed Rate (mm/min)	Spindle Speed (min ⁻¹)	Feed Rate (mm/min)
DC (mm)								
3.0	16,500	2,000	14,700	1,750	8,200	600	16,500	2,000
4.0	12,300	2,000	11,000	1,750	6,100	600	12,300	2,000
5.0	9,800	2,000	8,800	1,750	4,900	600	9,800	2,000
Standard Depth of Cut	ap	1.5DC	1.5DC		1.0DC		1.5DC	
	ae	0.1DC	0.1DC		0.02DC		0.1DC	

Endmills

I

Square

Radius

Ballnose

Multi-Purpose

General-Purpose

High Efficiency

Hardened Steel

Roughing

Non-Ferrous Metal

CFRP

Coated

Uncoated

HHM 6000ZX type

General Steel Carbon Steel Alloy Steel Pre-hardened Steel Tempered Steel / Die Steel Hardened Steel 45 to 55HRC Hardened Steel 55 to 60HRC

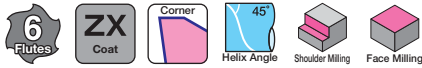
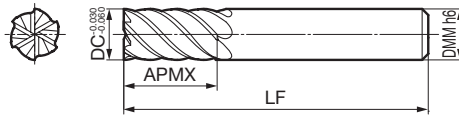

Fig 1



Body (6 Flutes)

Dimensions (mm)

Cat. No.	Stock	Dia. DC	Cutting Edge Length APMX	Overall Length LF	Shank Dia. DMM	Fig
HHM 6060ZX	●	6.0	12.0	50	6	1
6080ZX	●	8.0	16.0	60	8	1
6100ZX	●	10.0	20.0	71	10	1
6120ZX	●	12.0	24.0	75	12	1

Grade: ACZ10M

Recommended Cutting Conditions

1. If the machine cannot achieve the recommended spindle speed, please use the maximum spindle speed available.
2. If cutting noise and vibration occur, please reduce the cutting conditions accordingly.

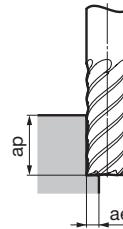

Side Milling

Work Material	Carbon Steel / Alloy Steel (Below 25HRC)		Carbon Steel / Alloy Steel (Below 45HRC)		Hardened Steel (Below 65HRC)		Cast Iron Special Cast Iron	
	Spindle Speed (min ⁻¹)	Feed Rate (mm/min)	Spindle Speed (min ⁻¹)	Feed Rate (mm/min)	Spindle Speed (min ⁻¹)	Feed Rate (mm/min)	Spindle Speed (min ⁻¹)	Feed Rate (mm/min)
DC (mm)								
6.0	8,200	2,900	7,300	2,600	4,100	900	8,200	2,900
8.0	6,100	2,900	5,500	2,600	3,100	900	6,100	2,900
10.0	4,900	2,900	4,400	2,600	2,500	900	4,900	2,900
12.0	4,100	2,900	3,650	2,600	2,100	900	4,100	2,900
Standard	1.5DC		1.5DC		1.0DC		1.5DC	
Depth of Cut	0.1DC		0.1DC		0.02DC		0.1DC	

Endmills

I

Square

Radius

Ballnose

Multi-Purpose

General-Purpose

High Efficiency

Hardened Steel

Roughing

Non-Ferrous Metal

CFRP

Coated

Uncoated

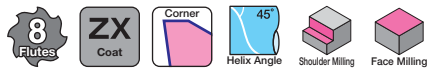
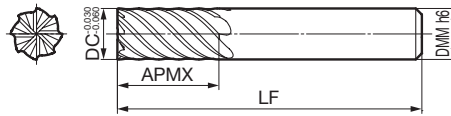

Fig 1



Body (8 Flutes)

Dimensions (mm)

Cat. No.	Stock	Dia. DC	Cutting Edge Length APMX	Overall Length LF	Shank Dia. DMM	Fig
HHM 8160ZX	●	16.0	32	90	16	1
8200ZX	●	20.0	40	106	20	1
8320ZX	●	32.0	64	130	32	1

Grade: ACZ10M

Recommended Cutting Conditions

1. If the machine cannot achieve the recommended spindle speed, please use the maximum spindle speed available.
2. If cutting noise and vibration occur, please reduce the cutting conditions accordingly.

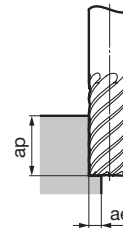

Side Milling

Work Material Cutting Conditions	Carbon Steel / Alloy Steel (Below 25HRC)		Carbon Steel / Alloy Steel (Below 45HRC)		Hardened Steel (Below 65HRC)		Cast Iron Special Cast Iron	
	Spindle Speed (min ⁻¹)	Feed Rate (mm/min)	Spindle Speed (min ⁻¹)	Feed Rate (mm/min)	Spindle Speed (min ⁻¹)	Feed Rate (mm/min)	Spindle Speed (min ⁻¹)	Feed Rate (mm/min)
DC (mm)								
16.0	3,100	3,500	2,750	3,200	1,550	1,100	3,100	3,500
20.0	2,500	3,150	2,200	2,800	1,250	950	2,500	3,150
32.0	1,550	2,400	1,350	1,950	780	700	1,550	2,400
Standard	1.5DC		1.5DC		1.0DC		1.5DC	
Depth of Cut	0.1DC		0.1DC		0.02DC		0.1DC	

LHHM 4000ZX type

General Steel Carbon Steel Alloy Steel Pre-hardened Steel Tempered Steel / Die Steel Hardened Steel 45 to 55HRC Hardened Steel 55 to 60HRC

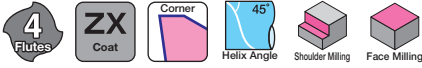
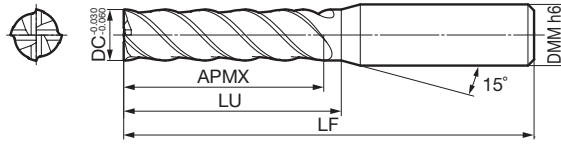

Fig 1



Body (4 Flutes)

Dimensions (mm)

Cat. No.	Stock	Dia. DC	Cutting Edge Length APMX	Neck Length LU	Overall Length LF	Shank Dia. DMM	Fig
LHHM 4030ZX	●	3.0	12.0	15.0	55	6	1
4040ZX	●	4.0	15.0	17.9	60	6	1
4050ZX	●	5.0	18.0	21.0	60	6	1

Grade: ACZ10M

Recommended Cutting Conditions

1. If the machine cannot achieve the recommended spindle speed, please use the maximum spindle speed available.
2. If cutting noise and vibration occur, please reduce the cutting conditions accordingly.

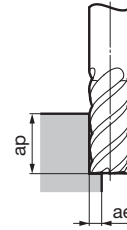

Side Milling

Work Material / Cutting Conditions	Carbon Steel / Alloy Steel (Below 25HRC)		Carbon Steel / Alloy Steel (Below 45HRC)		Hardened Steel (Below 65HRC)		Cast Iron / Special Cast Iron	
	Spindle Speed (min ⁻¹)	Feed Rate (mm/min)	Spindle Speed (min ⁻¹)	Feed Rate (mm/min)	Spindle Speed (min ⁻¹)	Feed Rate (mm/min)	Spindle Speed (min ⁻¹)	Feed Rate (mm/min)
DC (mm) 3.0	16,500	1,500	14,700	1,300	8,200	450	16,500	1,500
4.0	12,300	1,500	11,000	1,300	6,100	450	12,300	1,500
5.0	9,800	1,500	8,800	1,300	4,900	450	9,800	1,500
Standard Depth of Cut	ap 2.0DC		2.0DC		1.5DC		2.0DC	
ae	0.1DC		0.1DC		0.02DC		0.1DC	

Endmills

I

Square

Radius

Ballnose

Multi-Purpose

General-Purpose

High Efficiency

Hardened Steel

Roughing

Non-Ferrous Metal

CFRP

Coated

Uncoated

LHHM 6000ZX type

General Steel Carbon Steel Alloy Steel Pre-hardened Steel Tempered Steel / Die Steel Hardened Steel 45 to 55HRC Hardened Steel 55 to 60HRC

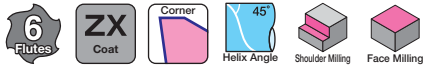
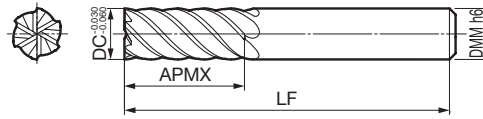

Fig 1



Body (6 Flutes)

Dimensions (mm)

Cat. No.	Stock	Dia. DC	Cutting Edge Length APMX	Overall Length LF	Shank Dia. DMM	Fig
LHHM 6060ZX	●	6.0	18.0	60	6	1
6080ZX	●	8.0	25.0	75	8	1
6100ZX	●	10.0	30.0	80	10	1
6120ZX	●	12.0	30.0	100	12	1

Grade: ACZ10M

Recommended Cutting Conditions

1. If the machine cannot achieve the recommended spindle speed, please use the maximum spindle speed available.
2. If cutting noise and vibration occur, please reduce the cutting conditions accordingly.

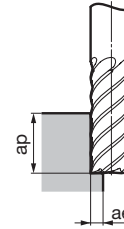

Side Milling

Work Material / Cutting Conditions	Carbon Steel / Alloy Steel (Below 25HRC)		Carbon Steel / Alloy Steel (Below 45HRC)		Hardened Steel (Below 65HRC)		Cast Iron / Special Cast Iron	
	Spindle Speed (min ⁻¹)	Feed Rate (mm/min)	Spindle Speed (min ⁻¹)	Feed Rate (mm/min)	Spindle Speed (min ⁻¹)	Feed Rate (mm/min)	Spindle Speed (min ⁻¹)	Feed Rate (mm/min)
DC (mm) 6.0	8,200	2,200	7,300	2,000	4,150	700	8,200	2,200
8.0	6,100	2,200	5,500	2,000	3,100	700	6,100	2,200
10.0	4,900	2,200	4,400	2,000	2,500	700	4,900	2,200
12.0	4,100	2,200	3,700	2,000	2,100	700	4,100	2,200
Standard Depth of Cut	ap	2.0DC	2.0DC	2.0DC	1.5DC	1.5DC	2.0DC	2.0DC
ae		0.1DC	0.1DC	0.1DC	0.02DC	0.02DC	0.1DC	0.1DC

Endmills

I

Square

Radius

Ballnose

Multi-Purpose

General-Purpose

High Efficiency

Hardened Steel

Roughing

Non-Ferrous Metal

CFRP

Coated

Uncoated

LHHM 8000ZX type

General Steel Carbon Steel Alloy Steel Pre-hardened Steel Tempered Steel / Die Steel Hardened Steel 45 to 55HRC Hardened Steel 55 to 60HRC

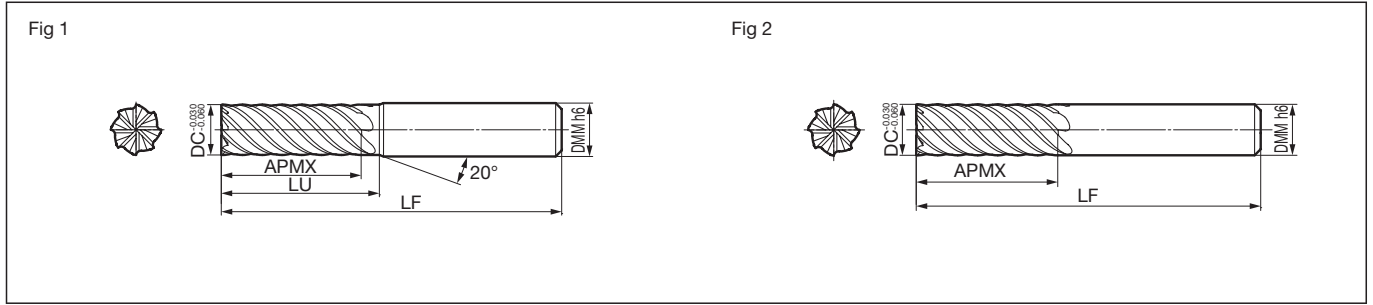
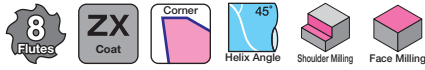

Body (8 Flutes)

Dimensions (mm)

Cat. No.	Stock	Dia. DC	Cutting Edge Length APMX	Neck Length LU	Overall Length LF	Shank Dia. DMM	Fig
LHHM 8160ZX	●	16.0	50.0	—	105	16	2
8200ZX	●	20.0	55.0	—	120	20	2
8250ZX	●	25.0	65.0	—	140	25	2
8300ZX	●	30.0	75.0	86.5	160	32	1
8320ZX	●	32.0	85.0	—	170	32	2

Grade: ACZ10M

Recommended Cutting Conditions

1. If the machine cannot achieve the recommended spindle speed, please use the maximum spindle speed available.
2. If cutting noise and vibration occur, please reduce the cutting conditions accordingly.

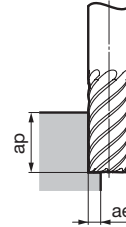

Side Milling

Work Material Cutting Conditions	Carbon Steel / Alloy Steel (Below 25HRC)		Carbon Steel / Alloy Steel (Below 45HRC)		Hardened Steel (Below 65HRC)		Cast Iron Special Cast Iron	
	Spindle Speed (min ⁻¹)	Feed Rate (mm/min)	Spindle Speed (min ⁻¹)	Feed Rate (mm/min)	Spindle Speed (min ⁻¹)	Feed Rate (mm/min)	Spindle Speed (min ⁻¹)	Feed Rate (mm/min)
DC (mm)								
16.0	3,100	2,700	2,750	2,400	1,550	800	3,100	2,700
20.0	2,500	2,400	2,200	2,100	1,250	700	2,500	2,400
25.0	2,000	2,100	1,750	1,700	1,000	600	2,000	2,000
32.0	1,550	1,800	1,350	1,500	780	550	1,550	1,800
Standard	ap 2.0DC		2.0DC		1.5DC		2.0DC	
Depth of Cut	ae 0.1DC		0.1DC		0.02DC		0.1DC	

Endmills

I

Square

Radius

Ballnose

Multi-Purpose

General-Purpose

High Efficiency

Hardened Steel

Roughing

Non-Ferrous Metal

CFRP

Coated

Uncoated

EHHM 4000ZX type

General Steel Carbon Steel Alloy Steel Pre-hardened Steel Tempered Steel / Die Steel Hardened Steel 45 to 55HRC Hardened Steel 55 to 60HRC

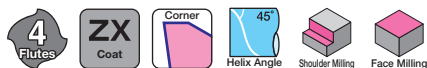
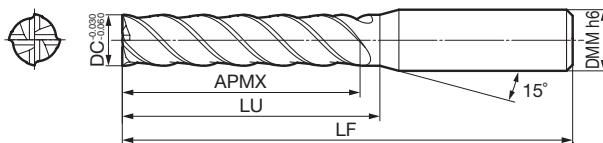

Fig 1



Body (4 Flutes)

Dimensions (mm)

Cat. No.	Stock	Dia. DC	Cutting Edge Length APMX	Neck Length LU	Overall Length LF	Shank Dia. DMM	Fig
EHHM 4030ZX	●	3.0	20.0	23.0	60	6	1
4040ZX	●	4.0	25.0	27.9	65	6	1
4050ZX	●	5.0	30.0	33.0	70	6	1

Grade: ACZ10M

Recommended Cutting Conditions

1. If the machine cannot achieve the recommended spindle speed, please use the maximum spindle speed available.
2. If cutting noise and vibration occur, please reduce the cutting conditions accordingly.

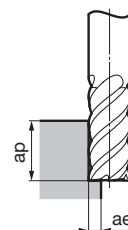

Side Milling

Work Material Cutting Conditions	Carbon Steel / Alloy Steel (Below 25HRC)		Carbon Steel / Alloy Steel (Below 45HRC)		Hardened Steel (Below 65HRC)		Cast Iron Special Cast Iron	
	Spindle Speed (min ⁻¹)	Feed Rate (mm/min)	Spindle Speed (min ⁻¹)	Feed Rate (mm/min)	Spindle Speed (min ⁻¹)	Feed Rate (mm/min)	Spindle Speed (min ⁻¹)	Feed Rate (mm/min)
DC (mm)								
3.0	5,800	700	4,600	400	1,800	90	5,800	700
4.0	4,400	650	3,500	400	1,350	100	4,400	650
5.0	3,500	600	2,800	400	1,100	110	3,500	600
Standard Depth of Cut	ap	2.0DC	2.0DC	2.0DC	2.0DC	2.0DC	2.0DC	2.0DC
	ae	0.05DC	0.02DC	0.01DC	0.01DC	0.05DC		

Endmills

I

Square

Radius

Ballnose

Multi-Purpose

General-Purpose

High Efficiency

Hardened Steel

Roughing

Non-Ferrous Metal

CFRP

Coated

Uncoated

EHHM 6000ZX type

General Steel Carbon Steel Alloy Steel Pre-hardened Steel Tempered Steel / Die Steel Hardened Steel 45 to 55HRC Hardened Steel 55 to 60HRC

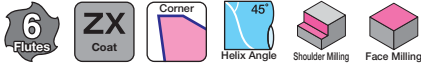
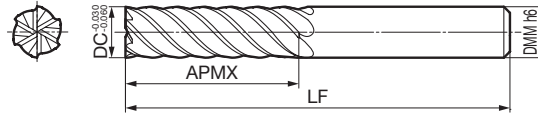

Fig 1



Body (6 Flutes)

Dimensions (mm)

Cat. No.	Stock	Dia. DC	Cutting Edge Length APMX	Overall Length LF	Shank Dia. DMM	Fig
EHHM 6060ZX	●	6.0	30.0	70	6	1
6080ZX	●	8.0	40.0	90	8	1
6100ZX	●	10.0	50.0	100	10	1
6120ZX	●	12.0	50.0	120	12	1

Grade: ACZ10M

Recommended Cutting Conditions

1. If the machine cannot achieve the recommended spindle speed, please use the maximum spindle speed available.
2. If cutting noise and vibration occur, please reduce the cutting conditions accordingly.

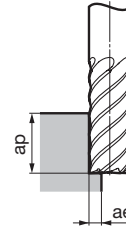

Side Milling

Work Material Cutting Conditions	Carbon Steel / Alloy Steel (Below 25HRC)		Carbon Steel / Alloy Steel (Below 45HRC)		Hardened Steel (Below 65HRC)		Cast Iron Special Cast Iron	
	Spindle Speed (min ⁻¹)	Feed Rate (mm/min)	Spindle Speed (min ⁻¹)	Feed Rate (mm/min)	Spindle Speed (min ⁻¹)	Feed Rate (mm/min)	Spindle Speed (min ⁻¹)	Feed Rate (mm/min)
DC (mm)								
6.0	2,900	810	2,300	590	900	160	2,900	810
8.0	2,400	860	2,000	620	800	170	2,400	860
10.0	2,100	920	1,800	650	700	170	2,100	920
12.0	1,750	880	1,500	580	600	170	1,750	880
Standard	2.0DC		2.0DC		2.0DC		2.0DC	
Depth of Cut	0.05DC		0.02DC		0.01DC		0.05DC	

Endmills

I

Square

Radius

Ballnose

Multi-Purpose

General-Purpose

High Efficiency

Hardened Steel

Roughing

Non-Ferrous Metal

CFRP

Coated

Uncoated

EHHM 8000ZX type

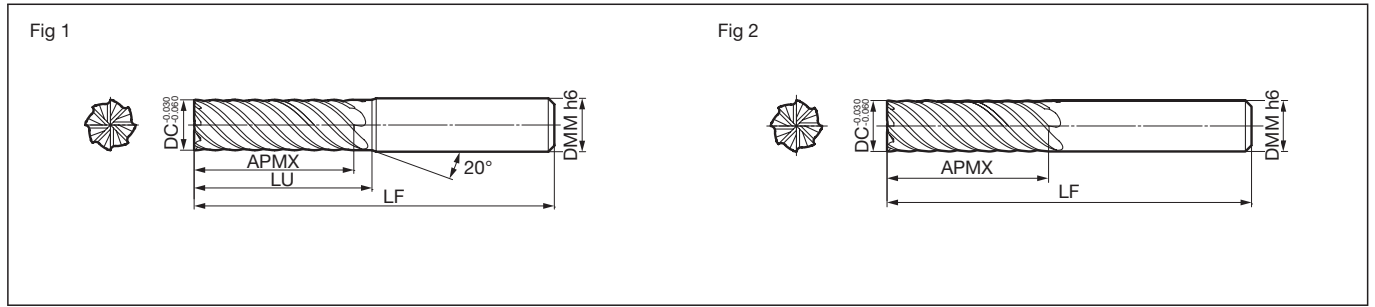
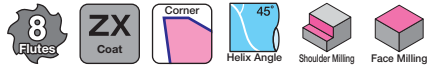

Body (8 Flutes)

Cat. No.	Stock	Dimensions (mm)					
		Dia. DC	Cutting Edge Length APMX	Neck Length LU	Overall Length LF	Shank Dia. DMM	Fig
EHHM 8160ZX	●	16.0	70.0	—	140	16	2
8200ZX	●	20.0	85.0	—	165	20	2
8250ZX	●	25.0	100.0	—	185	25	2
8300ZX	●	30.0	110.0	121.5	205	32	1
8320ZX	●	32.0	110.0	—	205	32	2

Grade: ACZ10M

Recommended Cutting Conditions

1. If the machine cannot achieve the recommended spindle speed, please use the maximum spindle speed available.
2. If cutting noise and vibration occur, please reduce the cutting conditions accordingly.

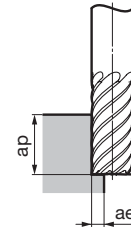

Side Milling

Work Material / Cutting Conditions	Carbon Steel / Alloy Steel (Below 25HRC)		Carbon Steel / Alloy Steel (Below 45HRC)		Hardened Steel (Below 65HRC)		Cast Iron / Special Cast Iron		
	Spindle Speed (min ⁻¹)	Feed Rate (mm/min)	Spindle Speed (min ⁻¹)	Feed Rate (mm/min)	Spindle Speed (min ⁻¹)	Feed Rate (mm/min)	Spindle Speed (min ⁻¹)	Feed Rate (mm/min)	
DC (mm)									
16.0	1,350	1,000	1,100	600	450	190	1,350	1,000	
20.0	1,100	850	900	520	350	160	1,100	850	
25.0	850	700	700	420	300	150	850	700	
32.0	680	580	550	350	220	120	680	580	
Standard Depth of Cut	ap	2.0DC		2.0DC		2.0DC		2.0DC	
	ae	0.05DC		0.02DC		0.01DC		0.05DC	

Endmills
I
Square
Radius
Ballnose
Multi-Purpose
General-Purpose
High Efficiency
Hardened Steel
Roughing
Non-Ferrous Metal
CFRP
Coated
Uncoated

GSRE 4000SF type

- General Steel
- Carbon Steel
- Alloy Steel
- Pre-hardened Steel
- Tempered Steel / Die Steel
- Hardened Steel 45 to 55HRC
- Stainless Steel
- Ti Alloy / Heat Resistant Alloy
- Cast Iron

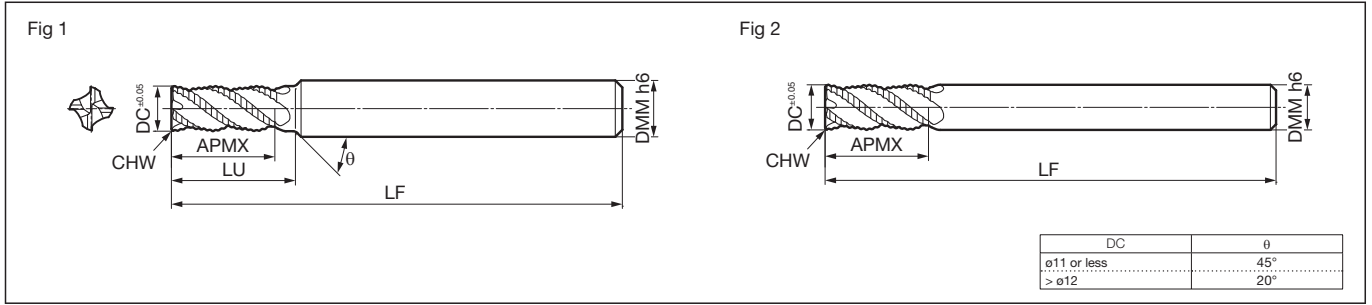

Body Dimensions (mm)

Cat. No.	Stock	Dia. DC	Cutting Edge Length APMX	Neck Length LU	Overall Length LF	Chamfer CHW	Shank Dia. DMM	Fig
GSRE 4060SF	●	6.0	13.0	—	50	0.3	6	2
4070SF	●	7.0	16.0	19.0	60	0.3	8	1
4080SF	●	8.0	19.0	—	60	0.4	8	2
4090SF	●	9.0	19.0	22.0	70	0.4	10	1
4100SF	●	10.0	22.0	—	70	0.5	10	2
GSRE 4110SF	●	11.0	22.0	25.0	75	0.5	12	1
4120SF	●	12.0	26.0	—	75	0.6	12	2
4140SF	●	14.0	26.0	30.0	90	0.6	16	1
4160SF	●	16.0	32.0	—	90	0.8	16	2
4180SF	●	18.0	32.0	40.0	100	0.8	20	1
GSRE 4200SF	●	20.0	38.0	—	100	1.0	20	2

Grade: ACZ20W

Endmills

I

Square

Radius

Ballnose

Multi-Purpose

General-Purpose

High Efficiency

Hardened Steel

Roughing

Non-Ferrous Metal

CFRP

Coated

Uncoated

GSRE 4000SF type

Recommended Cutting Conditions

1. If the machine cannot achieve the recommended spindle speed, please use the maximum spindle speed available.
2. If cutting noise and vibration occur, please reduce the cutting conditions accordingly.

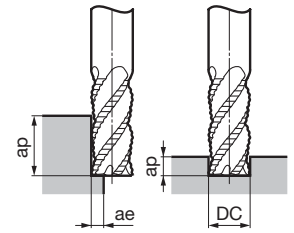

Side Milling

Work Material Cutting Conditions	Structural Steel, Carbon Steel (150 to 250HB)		Cast Iron FC, FCD		Alloy Steel (25 to 35HRC)		Hardened Steel (45 to 50HRC)		Stainless Steel SUS304, SUS316		Heat-Resistant Alloy Titanium Alloy		
	DC (mm)	Spindle Speed (min ⁻¹)	Feed Rate (mm/min)	Spindle Speed (min ⁻¹)	Feed Rate (mm/min)	Spindle Speed (min ⁻¹)	Feed Rate (mm/min)	Spindle Speed (min ⁻¹)	Feed Rate (mm/min)	Spindle Speed (min ⁻¹)	Feed Rate (mm/min)	Spindle Speed (min ⁻¹)	Feed Rate (mm/min)
6.0	4,800	1,200	5,800	1,500	3,200	380	2,600	400	5,300	250	1,600	90	
7.0	4,100	1,200	5,000	1,500	2,700	380	2,200	400	4,500	250	1,350	90	
8.0	3,600	1,200	4,500	1,500	2,400	380	2,000	400	4,000	250	1,250	90	
9.0	3,200	1,200	4,000	1,500	2,100	380	1,800	400	3,500	250	1,050	90	
10.0	2,800	1,200	3,500	1,500	1,900	380	1,600	400	3,200	250	1,000	100	
11.0	2,600	1,200	3,000	1,400	1,700	380	1,500	400	2,900	250	900	100	
12.0	2,400	1,200	2,900	1,400	1,600	400	1,300	400	2,600	250	800	100	
14.0	2,200	1,100	2,600	1,300	1,300	380	1,100	350	2,200	200	700	100	
16.0	1,800	900	2,200	1,100	1,200	380	1,000	350	2,000	180	600	100	
18.0	1,400	700	1,800	900	1,000	380	900	300	1,800	150	550	100	
20.0	1,400	700	1,700	850	850	380	800	300	1,600	150	500	100	
Standard Depth of Cut	ap	1.5DC						0.3DC					
ae	0.5DC						0.3DC						

Groove Milling

Work Material Cutting Conditions	Structural Steel, Carbon Steel (150 to 250HB)		Cast Iron FC, FCD		Alloy Steel (25 to 35HRC)		Hardened Steel (45 to 50HRC)		Stainless Steel SUS304, SUS316		Heat-Resistant Alloy Titanium Alloy		
	DC (mm)	Spindle Speed (min ⁻¹)	Feed Rate (mm/min)	Spindle Speed (min ⁻¹)	Feed Rate (mm/min)	Spindle Speed (min ⁻¹)	Feed Rate (mm/min)	Spindle Speed (min ⁻¹)	Feed Rate (mm/min)	Spindle Speed (min ⁻¹)	Feed Rate (mm/min)	Spindle Speed (min ⁻¹)	Feed Rate (mm/min)
6.0	3,600	900	4,300	1,100	2,400	300	1,700	260	4,200	250	1,100	60	
7.0	3,000	900	3,700	1,100	2,000	280	1,500	260	3,600	250	900	60	
8.0	2,700	900	3,400	1,100	1,800	280	1,350	260	3,200	250	800	60	
9.0	2,400	900	3,000	1,100	1,600	280	1,200	260	2,800	250	700	60	
10.0	2,100	900	2,600	1,100	1,400	280	1,100	270	2,500	250	650	65	
11.0	2,000	900	2,300	1,100	1,300	280	1,000	270	2,300	250	600	70	
12.0	1,800	900	2,200	1,100	1,200	300	900	270	2,100	250	550	70	
14.0	1,600	800	2,000	1,000	1,000	290	750	240	1,800	180	450	65	
16.0	1,350	650	1,650	850	900	280	700	240	1,600	160	400	65	
18.0	1,200	550	1,500	750	800	280	600	230	1,400	140	350	60	
20.0	1,050	500	1,350	700	700	280	550	210	1,250	125	300	60	
Standard Depth of Cut	ap	1.0DC						0.5DC					

Endmills

I

Square

Radius

Ballnose

Multi-Purpose

General-Purpose

High Efficiency

Hardened Steel

Roughing

Non-Ferrous Metal

CFRP

Coated

Uncoated

ASM 2000DL type

Aluminum Alloy
Copper Alloy



Endmills

I

Square

Radius

Ballnose

Multi-Purpose

General-Purpose

High Efficiency

Hardened Steel

Roughing

Non-Ferrous Metal

CFRP

Coated

Uncoated

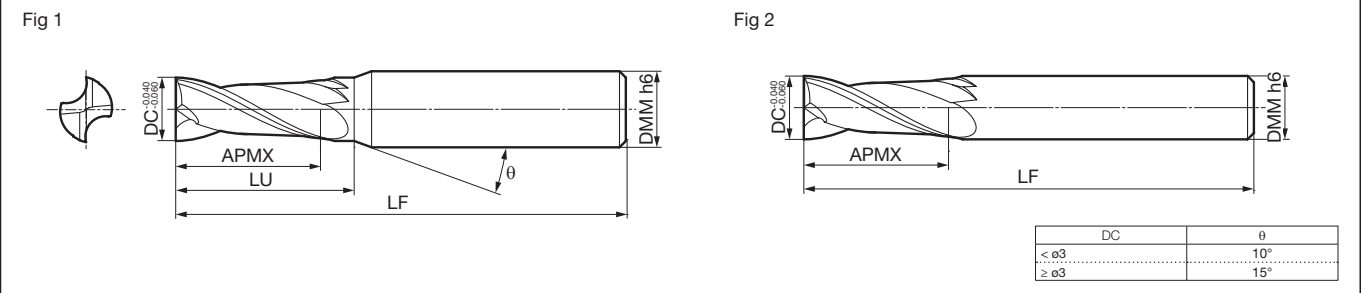

Body Dimensions (mm)

Cat. No.	Stock	Dia. DC	Cutting Edge Length APMX	Neck Length LU	Overall Length LF	Shank Dia. DMM	Fig
ASM 2020DL	●	2.0	6.0	6.8	40	4	1
2030DL	●	3.0	10.0	12.9	45	6	1
2040DL	●	4.0	12.0	14.7	45	6	1
2050DL	●	5.0	15.0	18.6	50	6	1
2060DL	●	6.0	15.0	—	50	6	2
ASM 2080DL	●	8.0	18.0	—	60	8	2
2100DL	●	10.0	22.0	—	71	10	2
2120DL	●	12.0	25.0	—	75	12	2
2160DL	●	16.0	32.0	—	90	16	2

Grade: DL1000

Recommended Cutting Conditions

1. If the machine cannot achieve the recommended spindle speed, please use the maximum spindle speed available.
2. If cutting noise and vibration occur, please reduce the cutting conditions accordingly.

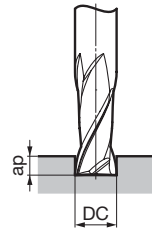

Groove Milling

Work Material	Aluminum Alloy			
	Wet		Dry	
	Spindle Speed (min ⁻¹)	Feed Rate (mm/min)	Spindle Speed (min ⁻¹)	Feed Rate (mm/min)
DC (mm)				
2.0	28,000	280	28,000	200
3.0	22,000	400	22,000	280
4.0	18,000	520	18,000	360
5.0	14,000	520	14,000	360
6.0	12,000	540	12,000	370
8.0	9,000	540	9,000	370
10.0	7,200	560	7,200	390
12.0	6,000	560	6,000	390
16.0	4,500	560	4,500	390
Standard	ap	1.0DC	0.5DC	
Depth of Cut	ae	1.0DC	1.0DC	

ASM 4000DL type

Aluminum Alloy
Copper Alloy

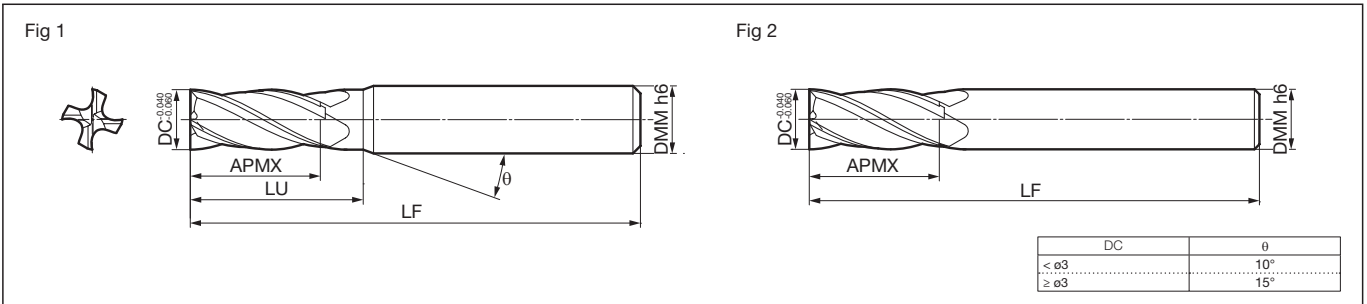

Body

Cat. No.	Stock	Dia. DC	Cutting Edge Length APMX	Neck Length LU	Overall Length		Shank Dia. DMM	Fig
					LF	LF		
ASM 4020DL	●	2.0	6.0	6.8	40	40	4	1
4030DL	●	3.0	10.0	12.9	45	45	6	1
4040DL	●	4.0	12.0	14.7	45	45	6	1
4050DL	●	5.0	15.0	18.6	50	50	6	1
4060DL	●	6.0	15.0	—	50	50	6	2
ASM 4080DL	●	8.0	18.0	—	60	60	8	2
4100DL	●	10.0	22.0	—	71	71	10	2
4120DL	●	12.0	25.0	—	75	75	12	2
4160DL	●	16.0	32.0	—	90	90	16	2

Grade: DL1000

Recommended Cutting Conditions

1. If the machine cannot achieve the recommended spindle speed, please use the maximum spindle speed available.
2. If cutting noise and vibration occur, please reduce the cutting conditions accordingly.

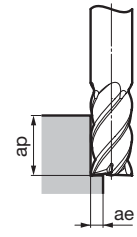

Side Milling

Work Material	Aluminum Alloy				
	Cutting Conditions	Wet		Dry	
		Spindle Speed (min ⁻¹)	Feed Rate (mm/min)	Spindle Speed (min ⁻¹)	Feed Rate (mm/min)
DC (mm)					
2.0	40,000	1,400	40,000	980	
3.0	32,000	2,000	32,000	1,400	
4.0	26,000	2,600	26,000	1,800	
5.0	20,000	2,600	20,000	1,800	
6.0	17,000	2,700	17,000	1,900	
8.0	13,000	2,700	13,000	1,900	
10.0	11,000	2,800	11,000	2,000	
12.0	8,500	2,800	8,500	2,000	
16.0	6,400	2,800	6,400	2,000	
Standard Depth of Cut	ap	1.5DC	1.5DC		
	ae	0.2DC	0.2DC		

Endmills
I
Square
Radius
Ballnose
Multi-Purpose
General-Purpose
High Efficiency
Hardened Steel
Roughing
Non-Ferrous Metal
CFRP
Coated
Uncoated

ASM 2000 type

Aluminum Alloy
Copper Alloy



Endmills

I

Square

Radius

Ballnose

Multi-Purpose

General-Purpose

High Efficiency

Hardened Steel

Roughing

Non-Ferrous Metal

CFRP

Coated

Uncoated

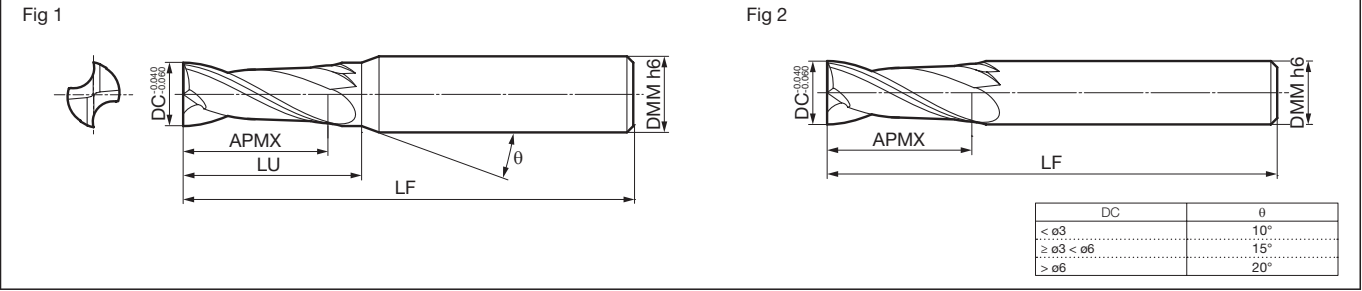

Body

Dimensions (mm)

Cat. No.	Stock	Dia. DC	Cutting Edge Length APMX	Neck Length LU	Overall Length LF	Shank Dia. DMM	Fig
ASM 2020	●	2.0	6	6.8	40	4	1
2030	●	3.0	10	12.9	45	6	1
2040	●	4.0	12	14.7	45	6	1
2050	●	5.0	15	18.6	50	6	1
2060	●	6.0	15	—	50	6	2
ASM 2080	●	8.0	18	—	60	8	2
2100	●	10.0	22	—	71	10	2
2120	●	12.0	25	—	75	12	2
2140	●	14.0	32	44.2	90	16	1
2150	●	15.0	32	44.1	90	16	1
ASM 2160	●	16.0	32	—	90	16	2

Grade: H1

Recommended Cutting Conditions

1. If the machine cannot achieve the recommended spindle speed, please use the maximum spindle speed available.
2. If cutting noise and vibration occur, please reduce the cutting conditions accordingly.

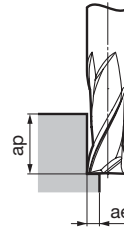

Side Milling

Work Material	Aluminum Alloy		Cast Iron Special Cast Iron	
	Spindle Speed (min ⁻¹)	Feed Rate (mm/min)	Spindle Speed (min ⁻¹)	Feed Rate (mm/min)
DC (mm)				
2.0	35,000	460	13,000	240
3.0	23,400	770	8,750	275
4.0	17,500	800	6,550	310
6.0	11,700	910	4,370	340
8.0	8,750	980	3,280	390
10.0	7,000	1,100	2,620	400
12.0	5,850	1,150	2,185	430
16.0	4,380	1,150	1,640	430
Standard	ap	1.5DC	1.5DC	
Depth of Cut	ae	0.1DC	0.1DC	

SUMIDIA Endmills

DFE series

Aluminum Alloy
Copper Alloy
Graphite



Fig 1

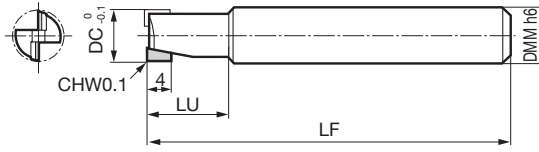

Body

Dimensions (mm)

Cat. No.	Stock	Dia. DC	Neck Length LU	Overall Length LF	Shank Dia. DMM	Fig
DFE 2040S	●	4.0	15	50	6	1
2050S	●	5.0	15	50	6	1
2080S	●	8.0	15	60	10	1
2090S	●	9.0	15	70	10	1
2100S	●	10.0	15	70	10	1

Grade: DA2200

Recommended Cutting Conditions

1. If the machine cannot achieve the recommended spindle speed, please use the maximum spindle speed available.
2. If cutting noise and vibration occur, please reduce the cutting conditions accordingly.

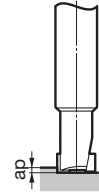

Face Milling (2 Flutes)

Work Material	Aluminum Alloy Copper Alloy	
	Spindle Speed (min ⁻¹)	Feed Rate (mm/min)
DC (mm)		
4.0	40,000	4,000
5.0	32,000	3,200
8.0	20,000	2,000
9.0	17,800	1,780
10.0	16,000	1,600
Standard Depth of Cut ap	0.4DC	

Endmills

I

Square

Radius

Ballnose

Multi-Purpose

General-Purpose

High Efficiency

Hardened Steel

Roughing

Non-Ferrous Metal

CFRP

Coated

Uncoated

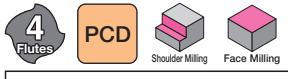

Endmills

I

Square

Radius

Ballnose

Multi-Purpose

General-Purpose

High Efficiency

Hardened Steel

Roughing

Non-Ferrous Metal

CFRP

Coated

Uncoated

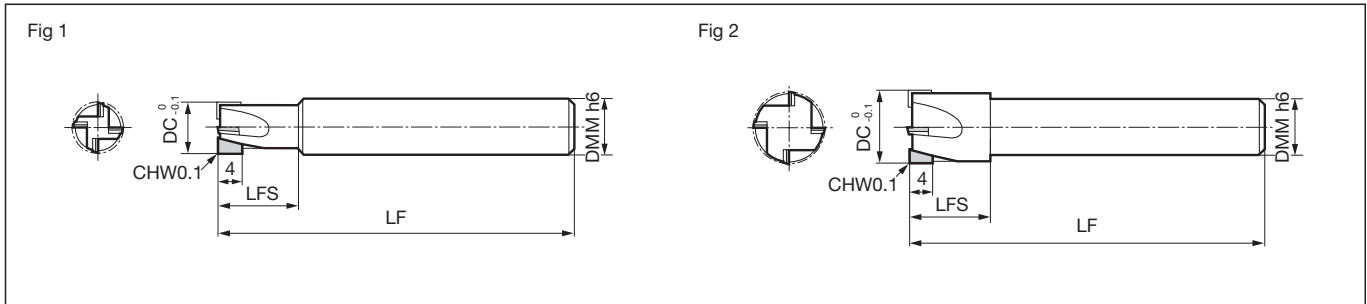

Body

Dimensions (mm)

Cat. No.	Stock	Dia. DC	Neck Length LFS	Overall Length LF	Shank Dia. DMM	Fig
DFE 4090S	●	9.0	15	70	10	1
4100S	●	10.0	15	70	10	1
4130GS	●	13.0	15	70	10	2

Grade: DA2200

Recommended Cutting Conditions

1. If the machine cannot achieve the recommended spindle speed, please use the maximum spindle speed available.
2. If cutting noise and vibration occur, please reduce the cutting conditions accordingly.

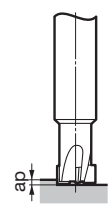

Face Milling (4 Flutes)

DC (mm)	Work Material	
	Aluminum Alloy	Copper Alloy
9.0	17,800	3,560
10.0	16,000	3,200
13.0	12,300	2,460
Standard Depth of Cut	ap 0.4DC	

SUMIDIA Endmills

DAE series

Aluminum Alloy
Copper Alloy
Graphite



Fig 1

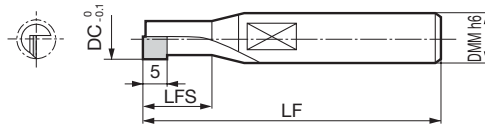

Body

Dimensions (mm)

Cat. No.	Stock	Dia. DC	Neck Length LFS	Overall Length LF	Shank Dia. DMM	Fig
DAE 1040	●	4.0	10	45	6	1
1050	●	5.0	12	50	6	1

Grade: DA200

Recommended Cutting Conditions

1. If the machine cannot achieve the recommended spindle speed, please use the maximum spindle speed available.
2. If cutting noise and vibration occur, please reduce the cutting conditions accordingly.

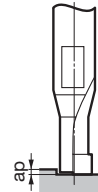

Face Milling (1 Flute)

Work Material	Aluminum Alloy Copper Alloy	
	Spindle Speed (min ⁻¹)	Feed Rate (mm/min)
DC (mm)		
4.0	6,000	210
5.0	5,000	175
Standard Depth of Cut	ap 0.4DC	

Endmills

I

Square

Radius

Ballnose

Multi-Purpose

General-Purpose

High Efficiency

Hardened Steel

Roughing

Non-Ferrous Metal

CFRP

Coated

Uncoated



Endmills

I

Square

Radius

Ballnose

Multi-Purpose

General-Purpose

High Efficiency

Hardened Steel

Roughing

Non-Ferrous Metal

CFRP

Coated

Uncoated

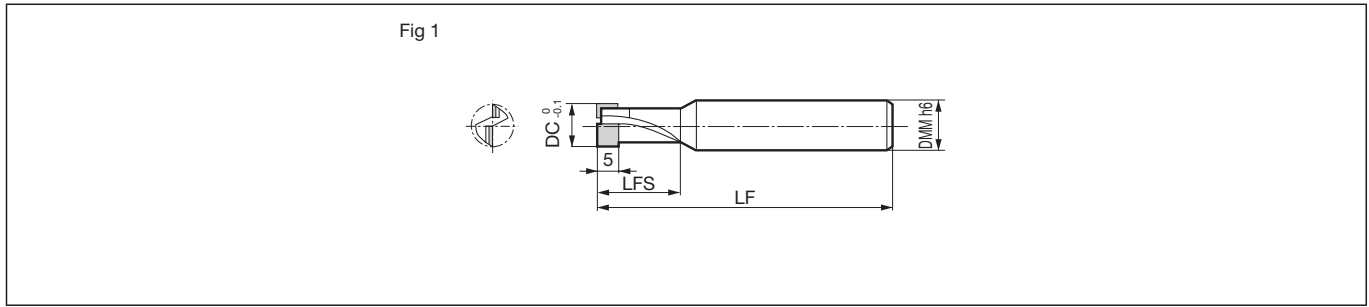

Body (2 Flutes)

Dimensions (mm)

Cat. No.	Stock	Dia. DC	Neck Length LFS	Overall Length LF	Shank Dia. DMM	Fig
DAE 2060	●	6.0	20	50	6	1
2070	●	7.0	20	60	8	1
2080	●	8.0	20	60	8	1
2090	●	9.0	25	71	10	1
2100	●	10.0	25	71	10	1
DAE 2110	●	11.0	25	75	12	1
2120	●	12.0	25	75	12	1

Grade: DA200

Recommended Cutting Conditions

1. If the machine cannot achieve the recommended spindle speed, please use the maximum spindle speed available.
2. If cutting noise and vibration occur, please reduce the cutting conditions accordingly.

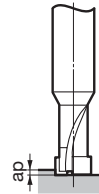

Face Milling (2 Flutes)

DC (mm)	Work Material	
	Aluminum Alloy Copper Alloy	
DC (mm)	Spindle Speed (min ⁻¹)	Feed Rate (mm/min)
6.0	6,400	580
7.0	5,500	500
8.0	5,400	500
9.0	5,300	480
10.0	4,800	440
11.0	4,400	400
12.0	4,000	360
Standard Depth of Cut	ap	0.4DC

SSDC 4000(RL) type

Graphite CFRP GFRP

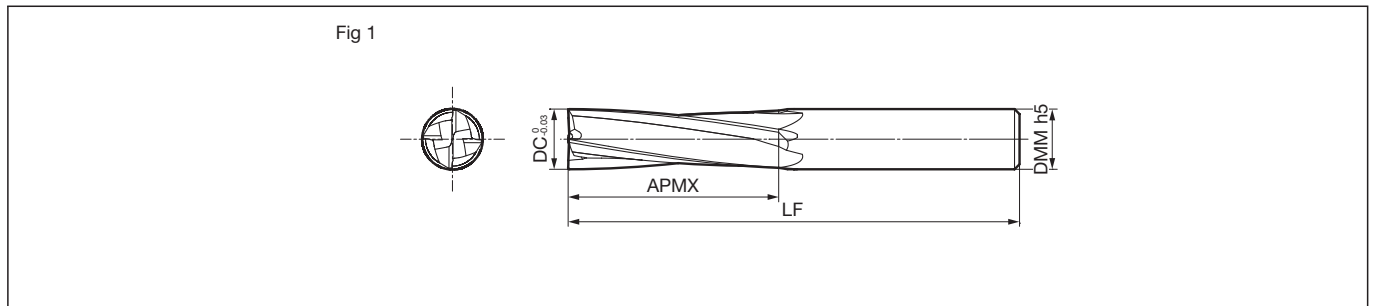
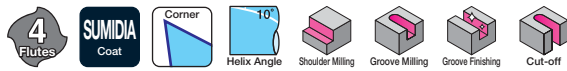

Body (Right-hand Helix type)

Dimensions (mm)

Cat. No.	Stock	Dia. DC	Cutting Edge Length APMX	Overall Length LF	Shank Dia. DMM	Fig
SSDC 4060	●	6.0	20	70	6	1
4080	●	8.0	30	80	8	1
4100	●	10.0	30	90	10	1
4120	●	12.0	30	100	12	1

Grade: DCX20

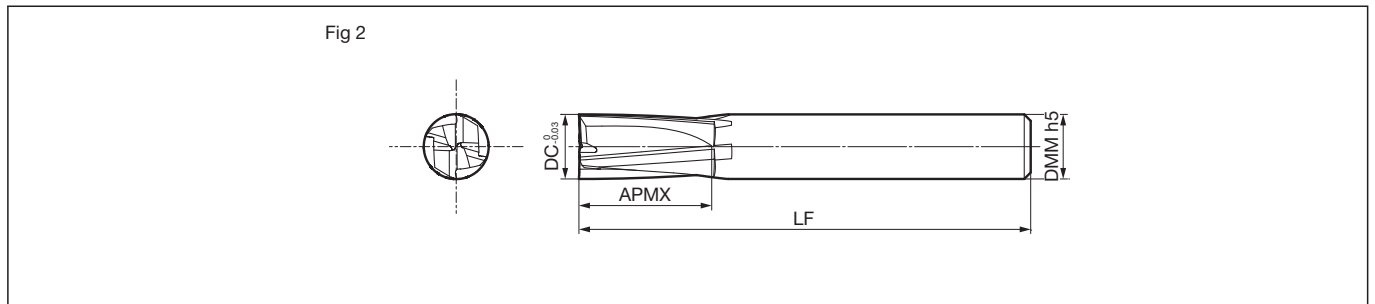
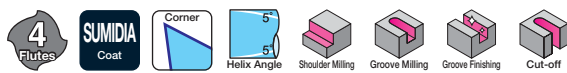

Body (Right-Left-hand Helix type)

Dimensions (mm)

Cat. No.	Stock	Dia. DC	Cutting Edge Length APMX	Overall Length LF	Shank Dia. DMM	Fig
SSDC 4060RL	●	6.0	20	70	6	2
4080RL	●	8.0	30	80	8	2
4100RL	●	10.0	30	90	10	2
4120RL	●	12.0	30	100	12	2

Grade: DCX20

Identification Code

SSDC 4 060 RL

Series Code No. of Flutes Dia. Helix Shape (RL: Right-Left-hand Helix)

Recommended Cutting Conditions

- The cutting conditions are guidelines. Cutting conditions are greatly influenced by clamping, work material grade, work material thickness and machine rigidity. Adjust the conditions accordingly.
- Take sufficient dust control measures.
- When radial depth of cut is 0.7D or more in groove milling and trimming, reduce feed rate accordingly.

Groove Milling (Common)

Work Material	CFRP			
	Cutting Conditions			
	Dry			
DC (mm)	Cutting Speed (m/min)	Spindle Speed (min ⁻¹)	Feed Rate (mm/min)	Feed Rate (mm/rev)
6.0	197.8	10,500	940	0.090
8.0	201.0	8,000	800	0.100
10.0	204.1	6,500	720	0.111
12.0	207.2	5,500	670	0.122

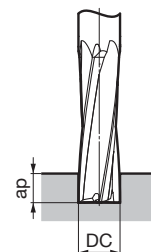

Endmills

I

Square

Radius

Ballnose

Multi-Purpose

General-Purpose

High Efficiency

Hardened Steel

Roughing

Non-Ferrous Metal

CFRP

Coated

Uncoated

GSX 40000-R-2D type

- General Steel
- Carbon Steel
- Alloy Steel
- Pre-hardened Steel
- Tempered Steel / Die Steel
- Hardened Steel 45 to 55HRC
- Stainless Steel
- Ti Alloy Heat Resistant Alloy
- Cast Iron



Endmills

I

Square

Radius

Ballnose

Multi-Purpose

General-Purpose

High Efficiency

Hardened Steel

Roughing

Non-Ferrous Metal

CFRP

Coated

Uncoated

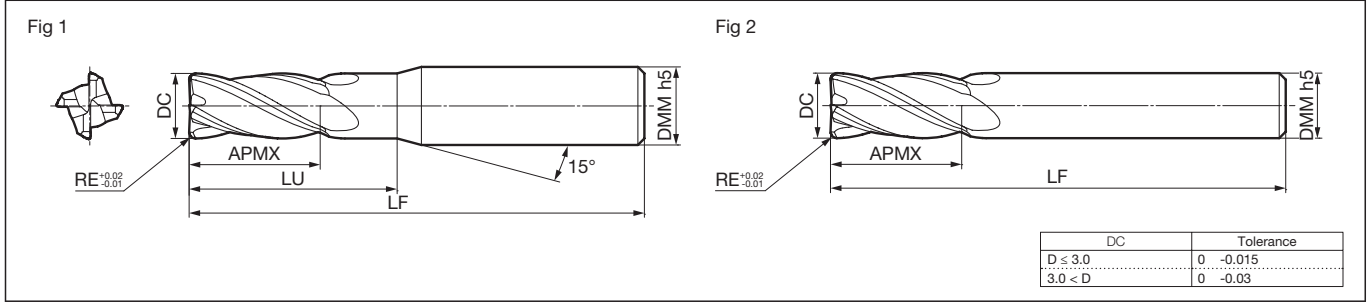

Body Dimensions (mm)

Cat. No.	Stock	Dia. DC	Corner Radius RE	Cutting Edge Length APMX	Neck Length LU	Overall Length LF	Shank Dia. DMM	Fig
GSX 40300-R02-2D	●	3.0	0.2	8.0	9.5	45	6	1
40300-R05-2D	●	3.0	0.5	8.0	9.5	45	6	1
40400-R02-2D	●	4.0	0.2	11.0	14.0	45	6	1
40400-R05-2D	●	4.0	0.5	11.0	14.0	45	6	1
40400-R10-2D	●	4.0	1.0	11.0	14.0	45	6	1
GSX 40500-R02-2D	●	5.0	0.2	13.0	19.6	50	6	1
40500-R05-2D	●	5.0	0.5	13.0	19.6	50	6	1
40500-R10-2D	●	5.0	1.0	13.0	19.6	50	6	1
40600-R02-2D	●	6.0	0.2	13.0	—	50	6	2
40600-R05-2D	●	6.0	0.5	13.0	—	50	6	2
GSX 40600-R10-2D	●	6.0	1.0	13.0	—	50	6	2
40600-R15-2D	●	6.0	1.5	13.0	—	50	6	2
40800-R02-2D	●	8.0	0.2	19.0	—	60	8	2
40800-R05-2D	●	8.0	0.5	19.0	—	60	8	2
40800-R10-2D	●	8.0	1.0	19.0	—	60	8	2
GSX 40800-R15-2D	●	8.0	1.5	19.0	—	60	8	2
41000-R02-2D	●	10.0	0.2	22.0	—	70	10	2
41000-R05-2D	●	10.0	0.5	22.0	—	70	10	2
41000-R10-2D	●	10.0	1.0	22.0	—	70	10	2
41000-R15-2D	●	10.0	1.5	22.0	—	70	10	2
GSX 41000-R20-2D	●	10.0	2.0	22.0	—	70	10	2
41200-R02-2D	●	12.0	0.2	26.0	—	75	12	2
41200-R05-2D	●	12.0	0.5	26.0	—	75	12	2
41200-R10-2D	●	12.0	1.0	26.0	—	75	12	2
41200-R15-2D	●	12.0	1.5	26.0	—	75	12	2
GSX 41200-R20-2D	●	12.0	2.0	26.0	—	75	12	2

Grade: ACF20

Identification Code

GSX 4 0300 - R 02 - 2D

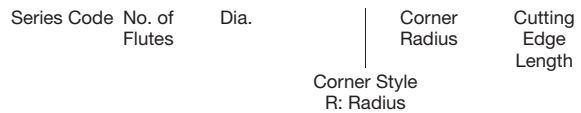

GSX 40000-R-2D type

Recommended Cutting Conditions

1. If the machine cannot achieve the recommended spindle speed, please use the maximum spindle speed available.
2. If cutting noise and vibration occur, please reduce the cutting conditions accordingly.
3. For Groove Milling of stainless steel, use 60% of the recommended spindle speed and 40% of the recommended feed rate. (*)

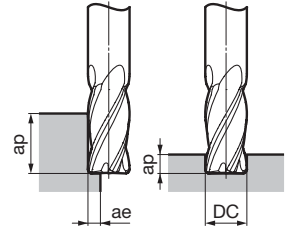

Side Milling

Work Material Cutting Conditions	Structural Steel, Carbon Steel, Cast Iron SS, SC, FC (150 to 250HB)		Alloy Steel SCM (25 to 35HRC)		Tempered Steel, Hardened Steel NAK, HPM (35 to 45HRC)		Hardened Steel (45 to 55HRC)		Stainless Steel (*) SUS304, SUS316		Heat-Resistant Alloy Titanium Alloy		
	DC (mm)	Spindle Speed (min ⁻¹)	Feed Rate (mm/min)	Spindle Speed (min ⁻¹)	Feed Rate (mm/min)	Spindle Speed (min ⁻¹)	Feed Rate (mm/min)	Spindle Speed (min ⁻¹)	Feed Rate (mm/min)	Spindle Speed (min ⁻¹)	Feed Rate (mm/min)	Spindle Speed (min ⁻¹)	Feed Rate (mm/min)
	2.0	12,800	570	12,000	380	8,300	230	6,000	150	6,000	130	3,700	70
	4.0	6,800	730	6,400	490	4,400	300	3,200	200	3,200	170	2,000	90
	6.0	4,600	770	4,300	520	3,000	320	2,200	210	2,200	180	1,400	100
	8.0	3,400	770	3,200	520	2,200	320	1,600	210	1,600	180	1,000	100
	10.0	2,800	780	2,600	520	1,800	320	1,300	210	1,300	180	800	100
	12.0	2,300	780	2,200	530	1,500	320	1,100	210	1,100	180	700	100
Standard Depth of Cut	ap	1.5DC		1.5DC		1.5DC		1.0DC		1.5DC		1.0DC	
	ae	0.1DC		0.1DC		0.05DC		0.02DC		0.1DC		0.05DC	

Groove Milling

Work Material Cutting Conditions	Structural Steel, Carbon Steel, Cast Iron SS, SC, FC (150 to 250HB)		Alloy Steel SCM (25 to 35HRC)		Tempered Steel, Hardened Steel NAK, HPM (35 to 45HRC)		Hardened Steel (45 to 55HRC)		Stainless Steel (*) SUS304, SUS316		Heat-Resistant Alloy Titanium Alloy		
	DC (mm)	Spindle Speed (min ⁻¹)	Feed Rate (mm/min)	Spindle Speed (min ⁻¹)	Feed Rate (mm/min)	Spindle Speed (min ⁻¹)	Feed Rate (mm/min)	Spindle Speed (min ⁻¹)	Feed Rate (mm/min)	Spindle Speed (min ⁻¹)	Feed Rate (mm/min)	Spindle Speed (min ⁻¹)	Feed Rate (mm/min)
	2.0	12,800	570	12,000	380	8,300	230	6,000	150	6,000	130	3,700	70
	4.0	6,800	730	6,400	490	4,400	300	3,200	200	3,200	170	2,000	90
	6.0	4,600	770	4,300	520	3,000	320	2,200	210	2,200	180	1,400	100
	8.0	3,400	770	3,200	520	2,200	320	1,600	210	1,600	180	1,000	100
	10.0	2,800	780	2,600	520	1,800	320	1,300	210	1,300	180	800	100
	12.0	2,300	780	2,200	530	1,500	320	1,100	210	1,100	180	700	100
Groove Milling	ap	0.5DC		0.5DC		0.2DC		0.05DC		0.3DC		0.1DC	

Side Milling (Using High Speed Machining Centre)

Work Material Cutting Conditions	Structural Steel, Carbon Steel, Cast Iron SS, SC, FC (150 to 250HB)		Alloy Steel SCM (25 to 35HRC)		Tempered Steel, Hardened Steel NAK, HPM (35 to 45HRC)		Hardened Steel (45 to 55HRC)		Stainless Steel (*)		
	DC (mm)	Spindle Speed (min ⁻¹)	Feed Rate (mm/min)	Spindle Speed (min ⁻¹)	Feed Rate (mm/min)	Spindle Speed (min ⁻¹)	Feed Rate (mm/min)	Spindle Speed (min ⁻¹)	Feed Rate (mm/min)	Spindle Speed (min ⁻¹)	Feed Rate (mm/min)
	2.0	47,800	2,200	47,800	1,600	39,800	1,200	31,800	900	15,900	400
	4.0	23,900	2,600	23,900	1,900	19,900	1,400	15,900	1,100	8,000	490
	6.0	16,000	2,700	16,000	2,000	13,300	1,500	10,600	1,200	5,300	510
	8.0	12,000	2,700	12,000	2,000	10,000	1,500	8,000	1,200	4,000	520
	10.0	9,600	2,700	9,600	2,000	8,000	1,500	6,400	1,200	3,200	520
	12.0	8,000	2,700	8,000	2,000	6,700	1,500	5,300	1,200	2,700	520
Standard Depth of Cut	ap	1.5DC		1.5DC		1.5DC		1.0DC		1.5DC	
	ae	0.05DC		0.05DC		0.05DC		0.02DC		0.05DC	

Endmills

I

Square

Radius

Ballnose

Multi-Purpose

General-Purpose

High Efficiency

Hardened Steel

Roughing

Non-Ferrous Metal

CFRP

Coated

Uncoated

GSV 4000-R-2.5D type

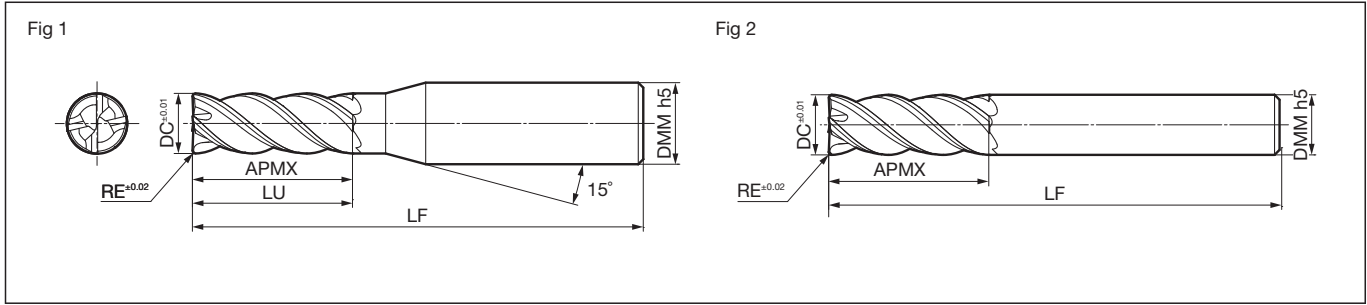

Body Dimensions (mm)

Cat. No.	Stock	Dia. DC	Corner Radius RE	Cutting Edge Length APMX	Neck Length LU	Overall Length LF	Shank Dia. DMM	Fig
GSV 4030-R02-2.5D	●	3.0	0.2	8.0	9.5	50	6	1
4030-R05-2.5D	●	3.0	0.5	8.0	9.5	50	6	1
4040-R02-2.5D	●	4.0	0.2	10.0	11.5	50	6	1
4040-R05-2.5D	●	4.0	0.5	10.0	11.5	50	6	1
4040-R10-2.5D	●	4.0	1.0	10.0	11.5	50	6	1
GSV 4050-R02-2.5D	●	5.0	0.2	13.0	14.5	60	6	1
4050-R05-2.5D	●	5.0	0.5	13.0	14.5	60	6	1
4050-R10-2.5D	●	5.0	1.0	13.0	14.5	60	6	1
4060-R03-2.5D	●	6.0	0.3	15.0	—	60	6	2
4060-R05-2.5D	●	6.0	0.5	15.0	—	60	6	2
GSV 4060-R10-2.5D	●	6.0	1.0	15.0	—	60	6	2
4060-R15-2.5D	●	6.0	1.5	15.0	—	60	6	2
4080-R03-2.5D	●	8.0	0.3	20.0	—	80	8	2
4080-R05-2.5D	●	8.0	0.5	20.0	—	80	8	2
4080-R10-2.5D	●	8.0	1.0	20.0	—	80	8	2
GSV 4080-R15-2.5D	●	8.0	1.5	20.0	—	80	8	2
4080-R20-2.5D	●	8.0	2.0	20.0	—	80	8	2
4100-R03-2.5D	●	10.0	0.3	25.0	—	90	10	2
4100-R05-2.5D	●	10.0	0.5	25.0	—	90	10	2
4100-R10-2.5D	●	10.0	1.0	25.0	—	90	10	2
GSV 4100-R15-2.5D	●	10.0	1.5	25.0	—	90	10	2
4100-R20-2.5D	●	10.0	2.0	25.0	—	90	10	2
4120-R05-2.5D	●	12.0	0.5	30.0	—	90	12	2
4120-R10-2.5D	●	12.0	1.0	30.0	—	90	12	2
4120-R15-2.5D	●	12.0	1.5	30.0	—	90	12	2
GSV 4120-R20-2.5D	●	12.0	2.0	30.0	—	90	12	2
4120-R30-2.5D	●	12.0	3.0	30.0	—	90	12	2
4160-R10-2.5D	●	16.0	1.0	40.0	—	115	16	2
4160-R15-2.5D	●	16.0	1.5	40.0	—	115	16	2
4160-R20-2.5D	●	16.0	2.0	40.0	—	115	16	2
GSV 4160-R30-2.5D	●	16.0	3.0	40.0	—	115	16	2
4200-R10-2.5D	●	20.0	1.0	50.0	—	125	20	2
4200-R15-2.5D	●	20.0	1.5	50.0	—	125	20	2
4200-R20-2.5D	●	20.0	2.0	50.0	—	125	20	2
4200-R30-2.5D	●	20.0	3.0	50.0	—	125	20	2
GSV 4250-R10-2.5D	●	25.0	1.0	63.0	—	140	25	2
4250-R15-2.5D	●	25.0	1.5	63.0	—	140	25	2
4250-R20-2.5D	●	25.0	2.0	63.0	—	140	25	2
4250-R30-2.5D	●	25.0	3.0	63.0	—	140	25	2

Grade: ACF20

Identification Code

GSV 4 030 - R 02 - 2.5D

Series Code No. of Flutes Dia. Corner Radius Cutting Edge Length

Corner Style
R: Radius

Endmills

I

Square

Radius

Ballnose

Multi-Purpose

General-Purpose

High Efficiency

Hardened Steel

Roughing

Non-Ferrous Metal

CFRP

Coated

Uncoated

GSX MILL 4 Flute Radius Endmills Anti-vibration type

GSV 4000-R-2.5D type

Recommended Cutting Conditions

1. For stable machining performance use rigid, high-precision machines and holders.
2. Use air blow when dry machining.
3. Use wet machining for stainless steel, heat-resistant alloy, and titanium alloy applications.
4. If the machine cannot achieve the recommended spindle speed, please use the maximum spindle speed available.

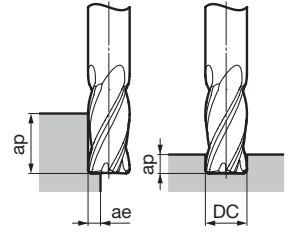

Side Milling

Work Material Cutting Conditions	Carbon Steel, Cast Iron SS, SC, FC (150 to 250HB)		Alloy Steel SCM (25 to 35HRC)		Tempered Steel / Hardened Steel NAK, HPM (40 to 50HRC)		Stainless Steel SUS304, SUS316		Titanium Alloy		
	DC (mm)	Spindle Speed (min ⁻¹)	Feed Rate (mm/min)	Spindle Speed (min ⁻¹)	Feed Rate (mm/min)	Spindle Speed (min ⁻¹)	Feed Rate (mm/min)	Spindle Speed (min ⁻¹)	Feed Rate (mm/min)	Spindle Speed (min ⁻¹)	Feed Rate (mm/min)
2.0	13,000	1,000	10,000	800	8,000	700	10,000	580	5,000	200	
4.0	9,600	1,200	8,000	1,000	6,000	800	5,500	650	3,000	230	
6.0	6,800	1,500	5,600	1,200	4,200	900	3,800	680	2,100	240	
8.0	5,200	1,600	4,400	1,300	3,200	950	2,800	650	1,600	250	
10.0	4,200	1,500	3,500	1,200	2,600	800	2,300	600	1,300	210	
12.0	3,500	1,400	3,000	1,200	2,200	700	1,900	550	1,100	180	
14.0	3,000	1,200	2,600	1,100	1,800	600	1,600	500	900	150	
16.0	2,700	1,100	2,200	1,000	1,600	600	1,400	480	760	130	
18.0	2,400	1,000	2,000	900	1,400	570	1,300	450	680	120	
20.0	2,200	900	1,700	800	1,200	550	1,100	400	600	100	
25.0	1,700	680	1,400	630	1,000	450	890	310	480	82	
Standard Depth of Cut	ap	1.5DC									
	ae	0.2DC		0.05DC		0.1DC		0.05DC			

Groove Milling

Work Material Cutting Conditions	Carbon Steel, Cast Iron SS, SC, FC (150 to 250HB)		Alloy Steel SCM (25 to 35HRC)		Tempered Steel / Hardened Steel NAK, HPM (40 to 50HRC)		Stainless Steel SUS304, SUS316		Titanium Alloy		
	DC (mm)	Spindle Speed (min ⁻¹)	Feed Rate (mm/min)	Spindle Speed (min ⁻¹)	Feed Rate (mm/min)	Spindle Speed (min ⁻¹)	Feed Rate (mm/min)	Spindle Speed (min ⁻¹)	Feed Rate (mm/min)	Spindle Speed (min ⁻¹)	Feed Rate (mm/min)
2.0	13,000	750	10,000	550	8,400	500	6,500	300	4,000	140	
4.0	8,200	800	6,000	600	5,200	500	4,000	330	2,000	130	
6.0	6,100	1,100	4,000	600	3,500	580	2,700	350	1,350	150	
8.0	4,600	1,000	3,000	580	2,600	570	2,000	330	1,000	140	
10.0	3,600	1,000	2,400	550	2,100	510	1,600	200	800	130	
12.0	3,100	920	2,000	500	1,700	450	1,300	280	660	110	
14.0	2,600	750	1,700	450	1,500	400	1,100	250	570	100	
16.0	2,300	670	1,500	420	1,300	350	1,000	230	500	90	
18.0	2,000	620	1,300	380	1,100	330	900	200	430	80	
20.0	1,900	600	1,200	360	1,000	320	800	180	380	70	
25.0	1,500	470	1,000	300	790	250	640	140	300	55	
Standard Depth of Cut	ap	0.8DC		0.16DC		0.4DC		0.16DC			

Endmills

I

Square

Radius

Ballnose

Multi-Purpose

General-Purpose

High Efficiency

Hardened Steel

Roughing

Non-Ferrous Metal

CFRP

Coated

Uncoated

GSXVL 4000-R-2.5D type

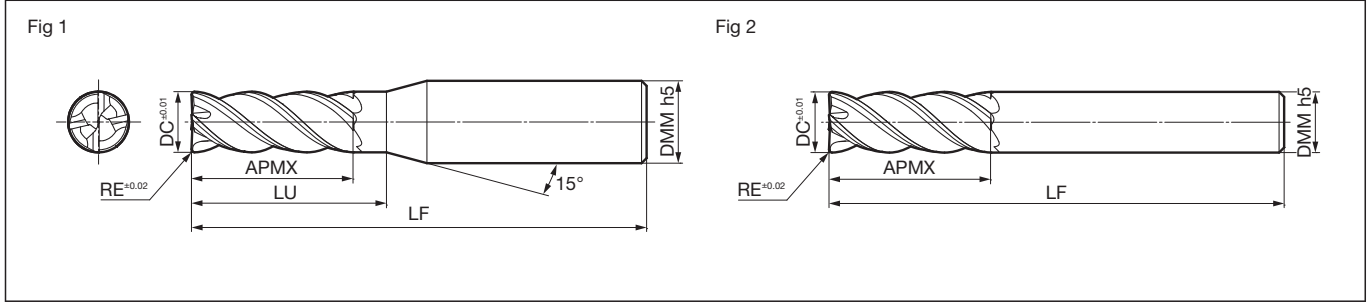

Body

Dimensions (mm)

Cat. No.	Stock	Dia. DC	Corner Radius RE	Cutting Edge Length APMX	Neck Length LU	Overall Length LF	Shank Dia. DMM	Fig
GSXVL 4030-R02-2.5D	●	3.0	0.2	8.0	9.5	50	6	1
4030-R05-2.5D	●	3.0	0.5	8.0	9.5	50	6	1
4040-R02-2.5D	●	4.0	0.2	10.0	11.5	50	6	1
4040-R05-2.5D	●	4.0	0.5	10.0	11.5	50	6	1
4040-R10-2.5D	●	4.0	1.0	10.0	11.5	50	6	1
GSXVL 4050-R02-2.5D	●	5.0	0.2	13.0	14.5	60	6	1
4050-R05-2.5D	●	5.0	0.5	13.0	14.5	60	6	1
4050-R10-2.5D	●	5.0	1.0	13.0	14.5	60	6	1
4060-R03-2.5D	●	6.0	0.3	15.0	—	60	6	2
4060-R05-2.5D	●	6.0	0.5	15.0	—	60	6	2
GSXVL 4060-R10-2.5D	●	6.0	1.0	15.0	—	60	6	2
4060-R15-2.5D	●	6.0	1.5	15.0	—	60	6	2
4080-R03-2.5D	●	8.0	0.3	20.0	—	80	8	2
4080-R05-2.5D	●	8.0	0.5	20.0	—	80	8	2
4080-R10-2.5D	●	8.0	1.0	20.0	—	80	8	2
GSXVL 4080-R15-2.5D	●	8.0	1.5	20.0	—	80	8	2
4080-R20-2.5D	●	8.0	2.0	20.0	—	80	8	2
4100-R03-2.5D	●	10.0	0.3	25.0	—	90	10	2
4100-R05-2.5D	●	10.0	0.5	25.0	—	90	10	2
4100-R10-2.5D	●	10.0	1.0	25.0	—	90	10	2
GSXVL 4100-R15-2.5D	●	10.0	1.5	25.0	—	90	10	2
4100-R20-2.5D	●	10.0	2.0	25.0	—	90	10	2
4120-R05-2.5D	●	12.0	0.5	30.0	—	90	12	2
4120-R10-2.5D	●	12.0	1.0	30.0	—	90	12	2
4120-R15-2.5D	●	12.0	1.5	30.0	—	90	12	2
GSXVL 4120-R20-2.5D	●	12.0	2.0	30.0	—	90	12	2
4120-R30-2.5D	●	12.0	3.0	30.0	—	90	12	2
4160-R10-2.5D	●	16.0	1.0	40.0	—	115	16	2
4160-R15-2.5D	●	16.0	1.5	40.0	—	115	16	2
4160-R20-2.5D	●	16.0	2.0	40.0	—	115	16	2
GSXVL 4160-R30-2.5D	●	16.0	3.0	40.0	—	115	16	2
4200-R10-2.5D	●	20.0	1.0	50.0	—	125	20	2
4200-R15-2.5D	●	20.0	1.5	50.0	—	125	20	2
4200-R20-2.5D	●	20.0	2.0	50.0	—	125	20	2
4200-R30-2.5D	●	20.0	3.0	50.0	—	125	20	2
GSXVL 4250-R10-2.5D	●	25.0	1.0	63.0	—	140	25	2
4250-R15-2.5D	●	25.0	1.5	63.0	—	140	25	2
4250-R20-2.5D	●	25.0	2.0	63.0	—	140	25	2
4250-R30-2.5D	●	25.0	3.0	63.0	—	140	25	2

Grade: ACF20



For the regrinding procedure, please download the details from our website.
https://www.sumitool.com/en/products/cutting-tools/endmills/pdf/gsxvl-regrinding_en.pdf

GSXVL 4000-R-2.5D type

Recommended Cutting Conditions

1. For stable machining performance use rigid, high-precision machines and holders.
2. Use air blow when dry machining.
3. Use wet machining for stainless steel, heat-resistant alloy, and titanium alloy applications.
4. If the machine cannot achieve the recommended spindle speed, please use the maximum spindle speed available.

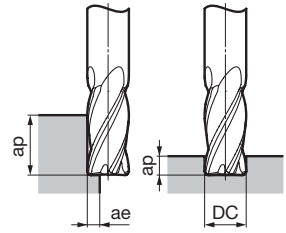

Side Milling

Work Material Cutting Conditions	Carbon Steel, Cast Iron SS, SC, FC (150 to 250HB)		Alloy Steel SCM (25 to 35HRC)		Tempered Steel / Hardened Steel NAK, HPM (40 to 50HRC)		Stainless Steel SUS304,SUS316		Titanium Alloy		
	DC (mm)	Spindle Speed (min ⁻¹)	Feed Rate (mm/min)	Spindle Speed (min ⁻¹)	Feed Rate (mm/min)	Spindle Speed (min ⁻¹)	Feed Rate (mm/min)	Spindle Speed (min ⁻¹)	Feed Rate (mm/min)	Spindle Speed (min ⁻¹)	Feed Rate (mm/min)
2.0	13,000	1,000	10,000	800	8,000	700	10,000	580	5,000	200	
4.0	9,600	1,200	8,000	1,000	6,000	800	5,500	650	3,000	230	
6.0	6,800	1,500	5,600	1,200	4,200	900	3,800	680	2,100	240	
8.0	5,200	1,600	4,400	1,300	3,200	950	2,800	650	1,600	250	
10.0	4,200	1,500	3,500	1,200	2,600	800	2,300	600	1,300	210	
12.0	3,500	1,400	3,000	1,200	2,200	700	1,900	550	1,100	180	
14.0	3,000	1,200	2,600	1,100	1,800	600	1,600	500	900	150	
16.0	2,700	1,100	2,200	1,000	1,600	600	1,400	480	760	130	
18.0	2,400	1,000	2,000	900	1,400	570	1,300	450	680	120	
20.0	2,200	900	1,700	800	1,200	550	1,100	400	600	100	
25.0	1,700	680	1,400	630	1,000	450	890	310	480	82	
Standard Depth of Cut	ap	1.5DC									
	ae	0.2DC		0.05DC		0.1DC		0.05DC			

Groove Milling

Work Material Cutting Conditions	Carbon Steel, Cast Iron SS, SC, FC (150 to 250HB)		Alloy Steel SCM (25 to 35HRC)		Tempered Steel / Hardened Steel NAK, HPM (40 to 50HRC)		Stainless Steel SUS304,SUS316		Titanium Alloy		
	DC (mm)	Spindle Speed (min ⁻¹)	Feed Rate (mm/min)	Spindle Speed (min ⁻¹)	Feed Rate (mm/min)	Spindle Speed (min ⁻¹)	Feed Rate (mm/min)	Spindle Speed (min ⁻¹)	Feed Rate (mm/min)	Spindle Speed (min ⁻¹)	Feed Rate (mm/min)
2.0	13,000	750	10,000	550	8,400	500	6,500	300	4,000	140	
4.0	8,200	800	6,000	600	5,200	500	4,000	330	2,000	130	
6.0	6,100	1,100	4,000	600	3,500	580	2,700	350	1,350	150	
8.0	4,600	1,000	3,000	580	2,600	570	2,000	330	1,000	140	
10.0	3,600	1,000	2,400	550	2,100	510	1,600	200	800	130	
12.0	3,100	920	2,000	500	1,700	450	1,300	280	660	110	
14.0	2,600	750	1,700	450	1,500	400	1,100	250	570	100	
16.0	2,300	670	1,500	420	1,300	350	1,000	230	500	90	
18.0	2,000	620	1,300	380	1,100	330	900	200	430	80	
20.0	1,900	600	1,200	360	1,000	320	800	180	380	70	
25.0	1,500	470	1,000	300	790	250	640	140	300	55	
Standard Depth of Cut	ap	1.0DC		0.2DC		0.5DC		0.2DC			

- Endmills
- I
- Square
- Radius
- Ballnose
- Multi-Purpose
- General-Purpose
- High Efficiency
- Hardened Steel
- Roughing
- Non-Ferrous Metal
- CFRP
- Coated
- Uncoated

Radius Endmills for Exotic Alloys, Anti-vibration type

SSEHVL 4000W-R type

Stainless Steel Ti Alloy / Heat Resistant Alloy



Endmills

I

Square

Radius

Ballnose

Multi-Purpose

General-Purpose

High Efficiency

Hardened Steel

Roughing

Non-Ferrous Metal

CFRP

Coated

Uncoated

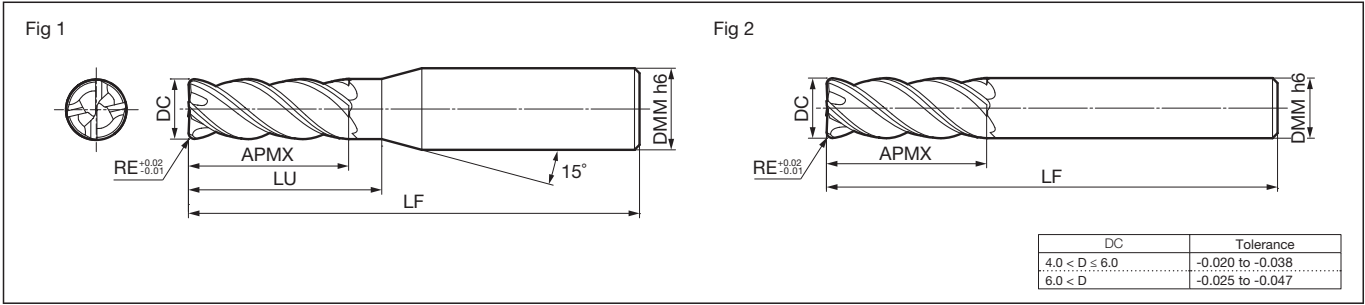

Body Dimensions (mm)

Cat. No.	Stock	Dia. DC	Radius RE	Cutting Edge Length APMX	Neck Length LU	Overall Length LF	Shank Dia. DMM	Fig
SSEHVL 4045W-R05	●	4.5	0.5	12.0	14.5	50	6	1
4045W-R10	●	4.5	1.0	12.0	14.5	50	6	1
4050W-R05	●	5.0	0.5	13.0	15.5	60	6	1
4050W-R10	●	5.0	1.0	13.0	15.5	60	6	1
4060W-R10	●	6.0	1.0	13.0	—	60	6	2
SSEHVL 4080W-R10	●	8.0	1.0	19.0	—	80	8	2
4100W-R10	●	10.0	1.0	22.0	—	90	10	2
4100W-R30	●	10.0	3.0	22.0	—	90	10	2
4120W-R10	●	12.0	1.0	26.0	—	90	12	2
4120W-R30	●	12.0	3.0	26.0	—	90	12	2
SSEHVL 4160W-R10	●	16.0	1.0	32.0	—	115	16	2
4160W-R30	●	16.0	3.0	32.0	—	115	16	2
4200W-R10	●	20.0	1.0	40.0	—	125	20	2
4200W-R30	●	20.0	3.0	40.0	—	125	20	2
4250W-R10	●	25.0	1.0	50.0	—	140	25	2
SSEHVL 4250W-R30	●	25.0	3.0	50.0	—	140	25	2

Grade: ACW52

SSEHVL 4000W-R type

Recommended Cutting Conditions

1. For stable machining, a high-rigidity machine is recommended.
2. Wet machining is recommended for stainless steel and heat-resistant alloy applications.
3. If cutting noise and vibration are present, please change the cutting conditions accordingly.

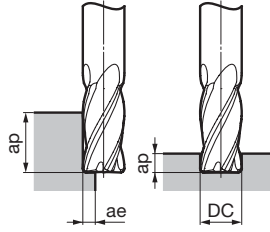

Side Milling

Work Material	Stainless Steel SUS304,SUS316		Titanium Alloy		Heat-Resistant Alloy	
	Spindle Speed (min ⁻¹)	Feed Rate (mm/min)	Spindle Speed (min ⁻¹)	Feed Rate (mm/min)	Spindle Speed (min ⁻¹)	Feed Rate (mm/min)
DC (mm)						
4.5	5,100	480	5,300	600	2,500	200
5.0	4,600	520	4,800	700	2,200	220
6.0	3,800	560	4,000	800	1,800	210
8.0	2,900	520	3,000	780	1,400	200
10.0	2,300	500	2,400	640	1,100	180
12.0	1,900	470	2,000	600	930	160
16.0	1,400	430	1,500	500	700	140
20.0	1,100	330	1,200	260	560	110
25.0	890	270	950	290	450	90
Standard Depth of Cut	ap	1.5DC	1.5DC		1.5DC	
	ae	0.1DC	0.05DC		0.05DC	

Groove Milling

Work Material	Stainless Steel SUS304,SUS316		Titanium Alloy		Heat-Resistant Alloy	
	Spindle Speed (min ⁻¹)	Feed Rate (mm/min)	Spindle Speed (min ⁻¹)	Feed Rate (mm/min)	Spindle Speed (min ⁻¹)	Feed Rate (mm/min)
DC (mm)						
4.5	4,200	200	3,900	270	1,400	100
5.0	3,800	240	3,500	300	1,300	120
6.0	3,200	260	2,900	300	1,100	140
8.0	2,400	240	2,200	270	800	120
10.0	1,900	220	1,700	250	650	110
12.0	1,600	200	1,400	230	550	100
16.0	1,200	130	1,100	200	400	80
20.0	950	95	890	90	320	60
25.0	760	75	700	70	250	50
Standard Depth of Cut	ap	0.3DC	0.2DC		0.15DC	

Radius Endmills for Exotic Alloys, Anti-vibration type SSEHVL 4000WS-R type

Stainless Steel
Ti Alloy / Heat Resistant Alloy



Fig 1

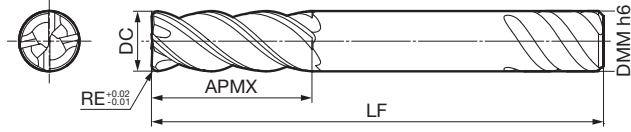

DC	Tolerance
4.0 < D ≤ 6.0	-0.020 to -0.038
6.0 < D	-0.025 to -0.047

Body (SAFE-LOCK™ Product)

Dimensions (mm)

Cat. No.	Stock	Dia. DC	Radius RE	Cutting Edge Length APMX	Overall Length LF	Shank Dia. DMM	Fig
SSEHVL 4120WS-R10	▲	12.0	1.0	26.0	90	12	1
4120WS-R30	▲	12.0	3.0	26.0	90	12	1
4160WS-R10	▲	16.0	1.0	32.0	115	16	1
4160WS-R30	▲	16.0	3.0	32.0	115	16	1
4200WS-R10	▲	20.0	1.0	40.0	125	20	1
SSEHVL 4200WS-R30	▲	20.0	3.0	40.0	125	20	1
4250WS-R10	▲	25.0	1.0	50.0	140	25	1
4250WS-R30	▲	25.0	3.0	50.0	140	25	1

Grade: ACW52

Endmills

I

Square

Radius

Ballnose

Multi-Purpose

General-Purpose

High Efficiency

Hardened Steel

Roughing

Non-Ferrous Metal

CFRP

Coated

Uncoated

SSEHVL 4000WS-R type

Recommended Cutting Conditions

1. For stable machining, a high-rigidity machine is recommended.
2. Wet machining is recommended for stainless steel and heat-resistant alloy applications.
3. If cutting noise and vibration are present, please change the cutting conditions accordingly.

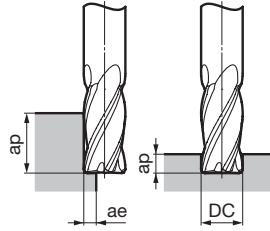

Side Milling

Work Material	Stainless Steel SUS304,SUS316		Titanium Alloy		Heat-Resistant Alloy	
	Spindle Speed (min ⁻¹)	Feed Rate (mm/min)	Spindle Speed (min ⁻¹)	Feed Rate (mm/min)	Spindle Speed (min ⁻¹)	Feed Rate (mm/min)
DC (mm)						
12.0	1,900	470	2,000	600	930	160
16.0	1,400	430	1,500	500	700	140
20.0	1,100	330	1,200	260	560	110
25.0	890	270	950	290	450	90
Standard Depth of Cut	ap	1.5DC	1.5DC	1.5DC	1.5DC	1.5DC
	ae	0.1DC	0.05DC	0.05DC	0.05DC	0.05DC

Groove Milling

Work Material	Stainless Steel SUS304,SUS316		Titanium Alloy		Heat-Resistant Alloy	
	Spindle Speed (min ⁻¹)	Feed Rate (mm/min)	Spindle Speed (min ⁻¹)	Feed Rate (mm/min)	Spindle Speed (min ⁻¹)	Feed Rate (mm/min)
DC (mm)						
12.0	1,600	200	1,400	230	550	100
16.0	1,200	130	1,100	200	400	80
20.0	950	95	890	90	320	60
25.0	760	75	700	70	250	50
Standard Depth of Cut	ap	0.3DC	0.2DC	0.2DC	0.15DC	0.15DC

SSEH 4000W-R type

Stainless Steel Ti Alloy / Heat Resistant Alloy

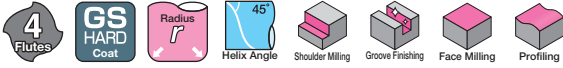

Endmills

I

Square

Radius

Ballnose

Multi-Purpose

General-Purpose

High Efficiency

Hardened Steel

Roughing

Non-Ferrous Metal

CFRP

Coated

Uncoated

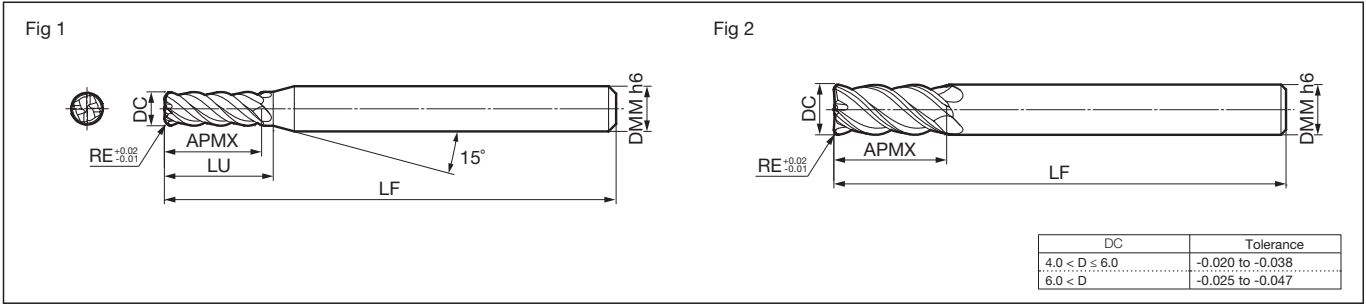

Body

Dimensions (mm)

Cat. No.	Stock	Dia. DC	Radius RE	Cutting Edge Length APMX	Neck Length LU	Overall Length LF	Shank Dia. DMM	Fig
SSEH 4045W-R05	●	4.5	0.5	12.0	14.5	50	6	1
4050W-R05	●	5.0	0.5	13.0	15.5	60	6	1
4060W-R10	●	6.0	1.0	13.0	—	60	6	2
4080W-R10	●	8.0	1.0	19.0	—	80	8	2
4100W-R10	●	10.0	1.0	22.0	—	90	10	2
SSEH 4100W-R30	●	10.0	3.0	22.0	—	90	10	2
4120W-R10	●	12.0	1.0	26.0	—	90	12	2
4120W-R30	●	12.0	3.0	26.0	—	90	12	2
4160W-R10	●	16.0	1.0	32.0	—	115	16	2
4160W-R30	●	16.0	3.0	32.0	—	115	16	2
SSEH 4200W-R10	●	20.0	1.0	40.0	—	125	20	2
4200W-R30	●	20.0	3.0	40.0	—	125	20	2
4250W-R10	●	25.0	1.0	50.0	—	140	25	2
4250W-R30	●	25.0	3.0	50.0	—	140	25	2

Grade: ACW52

SSEH 4000W-R type

Recommended Cutting Conditions

1. For stable machining, a high-rigidity machine is recommended.
2. Wet machining is recommended for stainless steel and heat-resistant alloy applications.
3. If cutting noise and vibration are present, please change the cutting conditions accordingly.

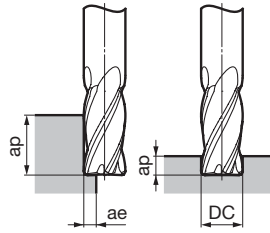

Side Milling

Work Material	Stainless Steel SUS304,SUS316		Titanium Alloy		Heat-Resistant Alloy	
	Spindle Speed (min ⁻¹)	Feed Rate (mm/min)	Spindle Speed (min ⁻¹)	Feed Rate (mm/min)	Spindle Speed (min ⁻¹)	Feed Rate (mm/min)
DC (mm)						
4.5	3,500	350	3,500	280	2,100	170
5.0	3,200	380	3,200	320	1,900	190
6.0	2,700	430	2,700	320	1,600	190
8.0	2,000	400	2,000	280	1,200	170
10.0	1,600	380	1,600	260	1,000	160
12.0	1,300	360	1,300	230	800	140
16.0	1,000	320	1,000	200	600	120
20.0	800	260	800	160	480	100
25.0	640	200	640	130	380	80
Standard Depth of Cut	ap	1.5DC	1.5DC	1.5DC	1.5DC	1.5DC
	ae	0.1DC	0.05DC	0.05DC	0.05DC	0.05DC

Groove Milling

Work Material	Stainless Steel SUS304,SUS316		Titanium Alloy		Heat-Resistant Alloy	
	Spindle Speed (min ⁻¹)	Feed Rate (mm/min)	Spindle Speed (min ⁻¹)	Feed Rate (mm/min)	Spindle Speed (min ⁻¹)	Feed Rate (mm/min)
DC (mm)						
4.5	2,800	140	2,500	200	1,300	100
5.0	2,500	150	2,200	220	1,100	110
6.0	2,100	170	1,900	230	1,000	120
8.0	1,600	160	1,400	200	700	100
10.0	1,300	160	1,100	180	600	100
12.0	1,100	150	900	160	500	90
16.0	800	130	700	140	400	80
20.0	640	100	560	110	320	65
25.0	510	85	450	90	250	50
Standard Depth of Cut	ap	0.3DC	0.2DC	0.2DC	0.15DC	0.15DC

SSEH 4000WS-R type

Stainless Steel Ti Alloy / Heat Resistant Alloy



Fig 1

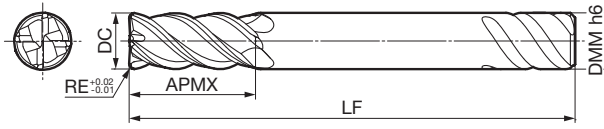

DC	Tolerance
4.0 < D ≤ 6.0	-0.020 to -0.038
6.0 < D	-0.025 to -0.047

Body (SAFE-LOCK™ Product)

Dimensions (mm)

Cat. No.	Stock	Dia. DC	Radius RE	Cutting Edge Length APMX	Overall Length LF	Shank Dia. DMM	Fig
SSEH 4120WS-R10	▲	12.0	1.0	26.0	90	12	1
4120WS-R30	▲	12.0	3.0	26.0	90	12	1
4160WS-R10	▲	16.0	1.0	32.0	115	16	1
4160WS-R30	▲	16.0	3.0	32.0	115	16	1
4200WS-R10	▲	20.0	1.0	40.0	125	20	1
SSEH 4200WS-R30	▲	20.0	3.0	40.0	125	20	1
4250WS-R10	▲	25.0	1.0	50.0	140	25	1
4250WS-R30	▲	25.0	3.0	50.0	140	25	1

Grade: ACW52

- Endmills
- I
- Square
- Radius
- Ballnose
- Multi-Purpose
- General-Purpose
- High Efficiency
- Hardened Steel
- Roughing
- Non-Ferrous Metal
- CFRP
- Coated
- Uncoated

SSEH 4000WS-R type

Recommended Cutting Conditions

1. For stable machining, a high-rigidity machine is recommended.
2. Wet machining is recommended for stainless steel and heat-resistant alloy applications.
3. If cutting noise and vibration are present, please change the cutting conditions accordingly.

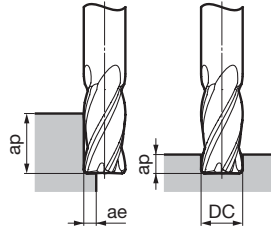

Side Milling

Work Material	Stainless Steel SUS304,SUS316		Titanium Alloy		Heat-Resistant Alloy	
	Spindle Speed (min ⁻¹)	Feed Rate (mm/min)	Spindle Speed (min ⁻¹)	Feed Rate (mm/min)	Spindle Speed (min ⁻¹)	Feed Rate (mm/min)
DC (mm)						
12.0	1,300	360	1,300	230	800	140
16.0	1,000	320	1,000	200	600	120
20.0	800	260	800	160	480	100
25.0	640	200	640	130	380	80
Standard Depth of Cut	ap	1.5DC	1.5DC	1.5DC	1.5DC	1.5DC
	ae	0.1DC	0.05DC	0.05DC	0.05DC	0.05DC

Groove Milling

Work Material	Stainless Steel SUS304,SUS316		Titanium Alloy		Heat-Resistant Alloy	
	Spindle Speed (min ⁻¹)	Feed Rate (mm/min)	Spindle Speed (min ⁻¹)	Feed Rate (mm/min)	Spindle Speed (min ⁻¹)	Feed Rate (mm/min)
DC (mm)						
12.0	1,100	150	900	160	500	90
16.0	800	130	700	140	400	80
20.0	640	100	560	110	320	65
25.0	510	85	450	90	250	50
Standard Depth of Cut	ap	0.3DC	0.2DC	0.2DC	0.15DC	0.15DC

SSUP 4000ZX-R type

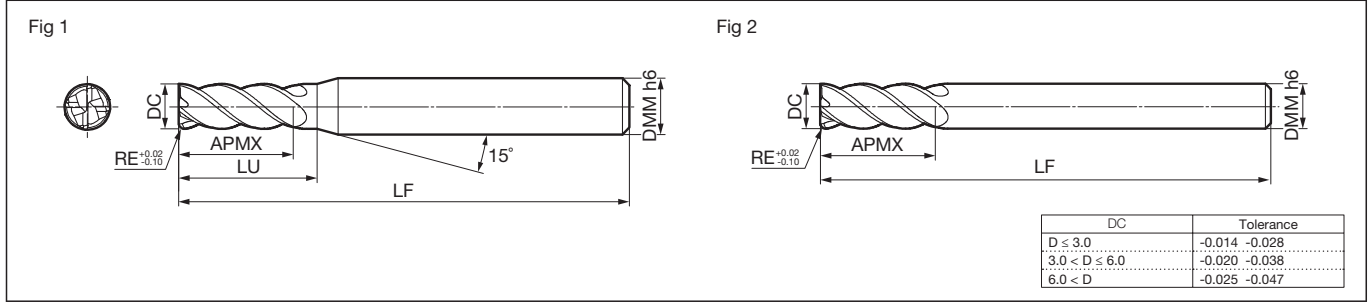

Body Dimensions (mm)

Cat. No.	Stock	Dia. DC	Radius RE	Cutting Edge Length APMX	Neck Length LU	Overall Length LF	Shank Dia. DMM	Fig
SSUP 4030ZX-R02	●	3.0	0.2	8.0	9.5	50	6	1
4030ZX-R05	●	3.0	0.5	8.0	9.5	50	6	1
4040ZX-R02	●	4.0	0.2	11.0	12.5	50	6	1
4040ZX-R05	●	4.0	0.5	11.0	12.5	50	6	1
4040ZX-R10	●	4.0	1.0	11.0	12.5	50	6	1
SSUP 4050ZX-R02	●	5.0	0.2	13.0	14.5	60	6	1
4050ZX-R05	●	5.0	0.5	13.0	14.5	60	6	1
4050ZX-R10	●	5.0	1.0	13.0	14.5	60	6	1
4060ZX-R03	●	6.0	0.3	13.0	—	60	6	2
4060ZX-R05	●	6.0	0.5	13.0	—	60	6	2
SSUP 4060ZX-R10	●	6.0	1.0	13.0	—	60	6	2
4060ZX-R15	●	6.0	1.5	13.0	—	60	6	2
4080ZX-R03	●	8.0	0.3	19.0	—	80	8	2
4080ZX-R05	●	8.0	0.5	19.0	—	80	8	2
4080ZX-R10	●	8.0	1.0	19.0	—	80	8	2
SSUP 4080ZX-R15	●	8.0	1.5	19.0	—	80	8	2
4080ZX-R20	●	8.0	2.0	19.0	—	80	8	2
4100ZX-R03	●	10.0	0.3	22.0	—	90	10	2
4100ZX-R05	●	10.0	0.5	22.0	—	90	10	2
4100ZX-R10	●	10.0	1.0	22.0	—	90	10	2
SSUP 4100ZX-R15	●	10.0	1.5	22.0	—	90	10	2
4100ZX-R20	●	10.0	2.0	22.0	—	90	10	2
4120ZX-R05	●	12.0	0.5	26.0	—	90	12	2
4120ZX-R10	●	12.0	1.0	26.0	—	90	12	2
4120ZX-R15	●	12.0	1.5	26.0	—	90	12	2
SSUP 4120ZX-R20	●	12.0	2.0	26.0	—	90	12	2
4120ZX-R30	●	12.0	3.0	26.0	—	90	12	2
4160ZX-R10	●	16.0	1.0	32.0	—	115	16	2
4160ZX-R15	●	16.0	1.5	32.0	—	115	16	2
4160ZX-R20	●	16.0	2.0	32.0	—	115	16	2
SSUP 4160ZX-R30	●	16.0	3.0	32.0	—	115	16	2
4200ZX-R10	●	20.0	1.0	38.0	—	125	20	2
4200ZX-R15	●	20.0	1.5	38.0	—	125	20	2
4200ZX-R20	●	20.0	2.0	38.0	—	125	20	2
4200ZX-R30	●	20.0	3.0	38.0	—	125	20	2

Grade: ACZ50M

Endmills

I

Square

Radius

Ballnose

Multi-Purpose

General-Purpose

High Efficiency

Hardened Steel

Roughing

Non-Ferrous Metal

CFRP

Coated

Uncoated

SSUP 4000ZX-R type

Recommended Cutting Conditions

1. For groove Milling of stainless steel, use 60% of the recommended spindle speed and 40% of the recommended feed rate. (*)
2. If cutting noise and vibration occur, please reduce the cutting conditions accordingly.

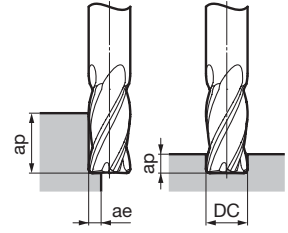

Side Milling and Groove Milling

Work Material Cutting Conditions	Carbon Steel, Cast Iron SS, SC, FC (150 to 250HB)		Alloy Steel SCM (25 to 35HRC)		Tempered Steel / Hardened Steel NAK, HPM (40 to 50HRC)		Stainless Steel (*)		Heat-Resistant Alloy Titanium Alloy (20 to 45HRC)		
	DC (mm)	Spindle Speed (min ⁻¹)	Feed Rate (mm/min)	Spindle Speed (min ⁻¹)	Feed Rate (mm/min)	Spindle Speed (min ⁻¹)	Feed Rate (mm/min)	Spindle Speed (min ⁻¹)	Feed Rate (mm/min)	Spindle Speed (min ⁻¹)	Feed Rate (mm/min)
	2.0	9,000	720	6,000	430	4,000	320	5,500	320	2,600	120
	4.0	6,600	800	4,500	450	3,000	380	4,000	320	2,000	120
	6.0	4,800	960	3,000	480	2,500	380	3,000	480	1,200	120
	8.0	3,600	1,000	2,200	610	2,000	400	2,000	520	1,000	140
	10.0	2,800	1,000	1,800	610	1,500	400	1,700	550	800	160
	12.0	2,400	950	1,500	550	1,200	380	1,500	500	700	140
	14.0	2,200	880	1,300	490	1,000	360	1,200	430	600	130
	16.0	1,800	650	1,100	420	800	300	1,000	360	500	120
	18.0	1,600	580	1,000	360	750	270	900	340	450	110
	20.0	1,400	500	900	330	700	250	820	300	400	100
Side Milling	ap	1.5DC									
	ae	0.1DC		0.05DC		0.1DC		0.05DC		0.2DC	
Groove Milling	ap	1.0DC									

Endmills

I

Square

Radius

Ballnose

Multi-Purpose

General-Purpose

High Efficiency

Hardened Steel

Roughing

Non-Ferrous Metal

CFRP

Coated

Uncoated

SSUPR 4000ZX-R type

General Steel Carbon Steel Alloy Steel Pre-hardened Steel Tempered Steel / Die Steel Stainless Steel Cast Iron

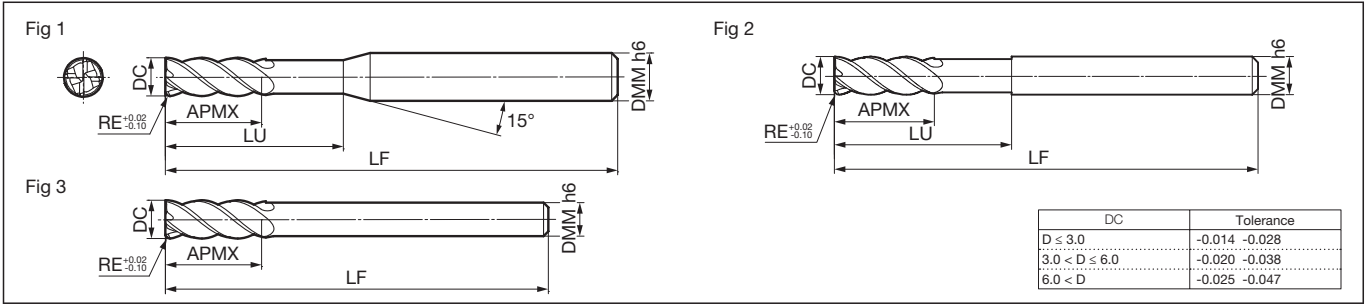
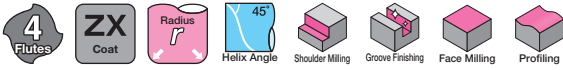

Body

Dimensions (mm)

Cat. No.	Stock	Dia. DC	Radius RE	Cutting Edge Length APMX	Neck Length LU	Overall Length LF	Shank Dia. DMM	Fig
SSUPR 4030ZX-R02	●	3.0	0.2	4.5	12.0	60	6	1
4030ZX-R05	●	3.0	0.5	4.5	12.0	60	6	1
4040ZX-R02	●	4.0	0.2	6.0	16.0	60	6	1
4040ZX-R05	●	4.0	0.5	6.0	16.0	60	6	1
4050ZX-R02	●	5.0	0.2	7.5	20.0	60	6	1
SSUPR 4050ZX-R05	●	5.0	0.5	7.5	20.0	60	6	1
4060ZX-R03	●	6.0	0.3	9.0	24.0	60	6	2
4060ZX-R05	●	6.0	0.5	9.0	24.0	60	6	2
4070ZX-R03	●	7.0	0.3	10.5	—	80	6	3
4070ZX-R05	●	7.0	0.5	10.5	—	80	6	3
SSUPR 4080ZX-R05	●	8.0	0.5	12.0	34.0	80	8	2
4080ZX-R10	●	8.0	1.0	12.0	34.0	80	8	2
4090ZX-R05	●	9.0	0.5	13.5	—	90	8	3
4090ZX-R10	●	9.0	1.0	13.5	—	90	8	3
4100ZX-R05	●	10.0	0.5	15.0	42.0	100	10	2
SSUPR 4100ZX-R10	●	10.0	1.0	15.0	42.0	100	10	2
4100ZX-R15	●	10.0	1.5	15.0	42.0	100	10	2
4110ZX-R05	●	11.0	0.5	16.5	—	120	10	3
4110ZX-R10	●	11.0	1.0	16.5	—	120	10	3
4110ZX-R15	●	11.0	1.5	16.5	—	120	10	3
SSUPR 4120ZX-R05	●	12.0	0.5	18.0	50.0	120	12	2
4120ZX-R10	●	12.0	1.0	18.0	50.0	120	12	2
4120ZX-R15	●	12.0	1.5	18.0	50.0	120	12	2
4130ZX-R05	●	13.0	0.5	19.5	—	130	12	3
4130ZX-R10	●	13.0	1.0	19.5	—	130	12	3
SSUPR 4130ZX-R15	●	13.0	1.5	19.5	—	130	12	3
4160ZX-R10	●	16.0	1.0	24.0	66.0	160	16	2
4160ZX-R15	●	16.0	1.5	24.0	66.0	160	16	2
4160ZX-R20	●	16.0	2.0	24.0	66.0	160	16	2
4170ZX-R10	●	17.0	1.0	25.5	—	170	16	3
SSUPR 4170ZX-R15	●	17.0	1.5	25.5	—	170	16	3
4170ZX-R20	●	17.0	2.0	25.5	—	170	16	3
4200ZX-R10	●	20.0	1.0	30.0	82.0	200	20	2
4200ZX-R15	●	20.0	1.5	30.0	82.0	200	20	2
4200ZX-R20	●	20.0	2.0	30.0	82.0	200	20	2

Grade: ACZ50M

Endmills

I

Square

Radius

Ballnose

Multi-Purpose

General-Purpose

High Efficiency

Hardened Steel

Roughing

Non-Ferrous Metal

CFRP

Coated

Uncoated

SSUPR 4000ZX-R type

Recommended Cutting Conditions

1. The conditions recommended are for endmills with standard overhang lengths of 4xD.
For overhangs of 5xD or more, please use 70% (max) of recommended conditions.
2. If cutting noise and vibration occur, please reduce the cutting conditions accordingly.

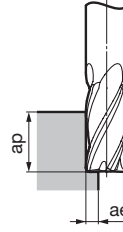

Side Milling

Work Material Cutting Conditions	Carbon Steel, Cast Iron (150 to 250HB)		Alloy Steel SCM (25 to 35HRC)		Tempered Steel / Hardened Steel NAK, HPM (40 to 50HRC)		Stainless Steel		Heat-Resistant Alloy Titanium Alloy (20 to 45HRC)		
	DC (mm)	Spindle Speed (min ⁻¹)	Feed Rate (mm/min)	Spindle Speed (min ⁻¹)	Feed Rate (mm/min)	Spindle Speed (min ⁻¹)	Feed Rate (mm/min)	Spindle Speed (min ⁻¹)	Feed Rate (mm/min)	Spindle Speed (min ⁻¹)	Feed Rate (mm/min)
	3.0	9,000	600	5,300	400	3,100	200	4,200	350	2,600	160
	4.0	6,600	600	4,000	400	2,400	200	3,200	350	2,000	160
	6.0	4,200	600	2,600	400	1,600	200	2,100	350	1,300	160
	8.0	3,200	650	2,000	450	1,200	200	1,600	350	1,000	160
	10.0	2,500	650	1,600	450	950	200	1,200	400	800	180
	12.0	2,100	650	1,300	450	800	200	1,000	400	650	180
	13.0	1,900	650	1,200	450	700	200	950	400	600	180
	16.0	1,600	650	1,000	400	600	200	800	350	500	160
	17.0	1,500	600	900	400	550	200	750	350	450	160
	20.0	1,200	600	800	400	500	200	650	350	400	160
Standard Depth of Cut	ap	1.2DC									
	ae	0.1DC			0.05DC		0.1DC		0.05DC		

GSH 6000SF-R type

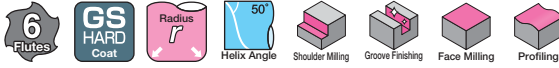
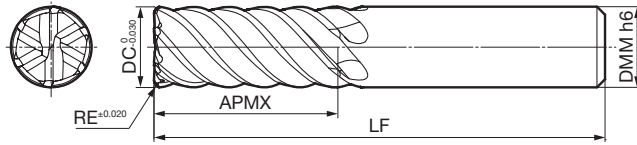

Fig 1



Body

Dimensions (mm)

Cat. No.	Stock	Dia. DC	Radius RE	Cutting Edge Length APMX	Overall Length LF	Shank Dia. DMM	Fig
GSH 6060SF-R02	●	6.0	0.2	13.0	50	6	1
6060SF-R05	●	6.0	0.5	13.0	50	6	1
6060SF-R10	●	6.0	1.0	13.0	50	6	1
6080SF-R02	●	8.0	0.2	19.0	60	8	1
6080SF-R05	●	8.0	0.5	19.0	60	8	1
GSH 6080SF-R10	●	8.0	1.0	19.0	60	8	1
6100SF-R05	●	10.0	0.5	22.0	70	10	1
6100SF-R10	●	10.0	1.0	22.0	70	10	1
6100SF-R15	●	10.0	1.5	22.0	70	10	1
6100SF-R20	●	10.0	2.0	22.0	70	10	1
GSH 6120SF-R05	●	12.0	0.5	26.0	75	12	1
6120SF-R10	●	12.0	1.0	26.0	75	12	1
6120SF-R15	●	12.0	1.5	26.0	75	12	1
6120SF-R20	●	12.0	2.0	26.0	75	12	1

Grade: ACF07C

Recommended Cutting Conditions

1. If the machine cannot achieve the recommended spindle speed, please use the maximum spindle speed available.
2. If cutting noise and vibration occur, please reduce the cutting conditions accordingly.

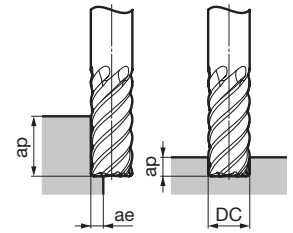

Side Milling and Groove Milling

Work Material Cutting Conditions	Low Carbon Steel Carbon Steel, Alloy Steel (Up to 35HRC)		Medium Hardened Steel Pre-hardened Steel, Die Steel (35 to 45HRC)		Hardened Steel SKD61 (45 to 55HRC)		Hardened Steel SKD11 (55 to 60HRC)		Hardened Steel SKH51 (60 to 65HRC)		Hardened Steel SKH55 (65 to 70HRC)	
	Spindle Speed (min ⁻¹)	Feed Rate (mm/min)	Spindle Speed (min ⁻¹)	Feed Rate (mm/min)	Spindle Speed (min ⁻¹)	Feed Rate (mm/min)	Spindle Speed (min ⁻¹)	Feed Rate (mm/min)	Spindle Speed (min ⁻¹)	Feed Rate (mm/min)	Spindle Speed (min ⁻¹)	Feed Rate (mm/min)
DC (mm)												
6.0	7,500	2,700	6,700	1,930	5,200	1,300	4,100	810	3,700	670	2,600	470
8.0	5,600	2,700	5,000	1,930	3,900	1,300	3,050	810	2,800	670	1,950	470
10.0	4,500	2,700	4,000	1,930	3,100	1,300	2,450	810	2,200	670	1,550	470
12.0	3,750	2,700	3,350	1,930	2,600	1,300	2,050	810	1,850	670	1,300	470
Side Milling	ap				1 to 1.5DC				0.02DC			
Groove Milling	ae				0.05DC				Up to 0.05DC Max. 0.5mm			

Side Milling (Using High Speed Machining Centre)

Work Material Cutting Conditions	Low Carbon Steel Carbon Steel, Alloy Steel (Up to 35HRC)		Medium Hardened Steel Pre-hardened Steel, Die Steel (35 to 45HRC)		Hardened Steel SKD61 (45 to 55HRC)		Hardened Steel SKD11 (55 to 60HRC)		Hardened Steel SKH51 (60 to 65HRC)	
	Spindle Speed (min ⁻¹)	Feed Rate (mm/min)	Spindle Speed (min ⁻¹)	Feed Rate (mm/min)	Spindle Speed (min ⁻¹)	Feed Rate (mm/min)	Spindle Speed (min ⁻¹)	Feed Rate (mm/min)	Spindle Speed (min ⁻¹)	Feed Rate (mm/min)
DC (mm)										
6.0	16,000	5,800	16,000	5,800	16,000	5,800	12,000	3,200	8,000	2,000
8.0	12,000	5,800	12,000	5,800	12,000	5,800	9,000	3,200	6,000	2,000
10.0	9,600	5,800	9,600	5,800	9,600	5,800	7,200	3,200	4,800	2,000
12.0	8,000	5,800	8,000	5,800	8,000	5,800	6,000	3,200	4,000	2,000
Standard Depth of Cut	ap				1 to 1.5DC				0.01DC	
	ae		0.05DC		0.05DC		0.02DC		0.01DC	

Endmills

I

Square

Radius

Ballnose

Multi-Purpose

General-Purpose

High Efficiency

Hardened Steel

Roughing

Non-Ferrous Metal

CFRP

Coated

Uncoated

GSH 8000SF-R type

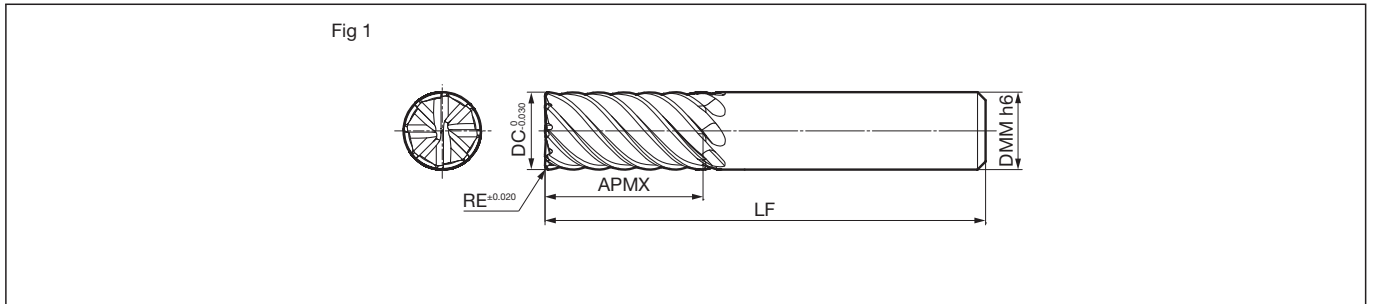
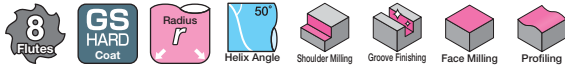

Body

Cat. No.	Stock	Dimensions (mm)					
		Dia. DC	Radius RE	Cutting Edge Length APMX	Overall Length LF	Shank Dia. DMM	Fig
GSH 8160SF-R10	●	16.0	1.0	32.0	90	16	1
8160SF-R15	●	16.0	1.5	32.0	90	16	1
8160SF-R20	●	16.0	2.0	32.0	90	16	1
8200SF-R10	●	20.0	1.0	38.0	100	20	1
8200SF-R15	●	20.0	1.5	38.0	100	20	1
GSH 8200SF-R20	●	20.0	2.0	38.0	100	20	1

Grade: ACF07C

Recommended Cutting Conditions

1. If the machine cannot achieve the recommended spindle speed, please use the maximum spindle speed available.
2. If cutting noise and vibration occur, please reduce the cutting conditions accordingly.

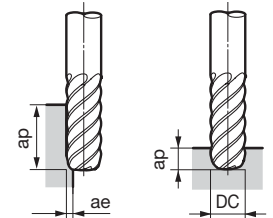

Side Milling and Groove Milling

Work Material / Cutting Conditions	Low Carbon Steel Carbon Steel, Alloy Steel (Up to 35HRC)		Medium Hardened Steel Pre-hardened Steel, Die Steel (35 to 45HRC)		Hardened Steel SKD61 (45 to 55HRC)		Hardened Steel SKD11 (55 to 60HRC)		Hardened Steel SKH51 (60 to 65HRC)		Hardened Steel SKH55 (65 to 70HRC)	
	Spindle Speed (min ⁻¹)	Feed Rate (mm/min)	Spindle Speed (min ⁻¹)	Feed Rate (mm/min)	Spindle Speed (min ⁻¹)	Feed Rate (mm/min)	Spindle Speed (min ⁻¹)	Feed Rate (mm/min)	Spindle Speed (min ⁻¹)	Feed Rate (mm/min)	Spindle Speed (min ⁻¹)	Feed Rate (mm/min)
DC (mm)	2,800	2,500	2,500	1,800	1,950	1,220	1,530	760	1,400	630	980	440
20.0	2,250	2,100	2,000	1,540	1,550	1,050	1,230	650	1,100	540	780	380
Side Milling ap	1 to 1.5DC						0.05DC					
ae	0.1DC						0.02DC					
Groove Milling ap	0.1DC						Up to 0.05DC Max. 0.5mm					

Side Milling (Using High Speed Machining Centre)

Work Material / Cutting Conditions	Low Carbon Steel Carbon Steel, Alloy Steel (Up to 35HRC)		Medium Hardened Steel Pre-hardened Steel, Die Steel (35 to 45HRC)		Hardened Steel SKD61 (45 to 55HRC)		Hardened Steel SKD11 (55 to 60HRC)		Hardened Steel SKH51 (60 to 65HRC)	
	Spindle Speed (min ⁻¹)	Feed Rate (mm/min)	Spindle Speed (min ⁻¹)	Feed Rate (mm/min)	Spindle Speed (min ⁻¹)	Feed Rate (mm/min)	Spindle Speed (min ⁻¹)	Feed Rate (mm/min)	Spindle Speed (min ⁻¹)	Feed Rate (mm/min)
DC (mm)	6,000	5,400	6,000	5,400	6,000	5,400	4,500	3,000	3,000	1,900
20.0	4,800	4,600	4,800	4,600	4,800	4,600	3,600	2,580	2,400	1,600
Standard Depth of Cut ap	1 to 1.5DC									
ae	0.1DC		0.05DC		0.05DC		0.02DC		0.01DC	

Endmills

I

Square

Radius

Ballnose

Multi-Purpose

General-Purpose

High Efficiency

Hardened Steel

Roughing

Non-Ferrous Metal

CFRP

Coated

Uncoated

SSEHVL 4000-R type

Stainless Steel Ti Alloy / Heat Resistant Alloy

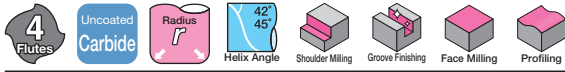

Endmills
I

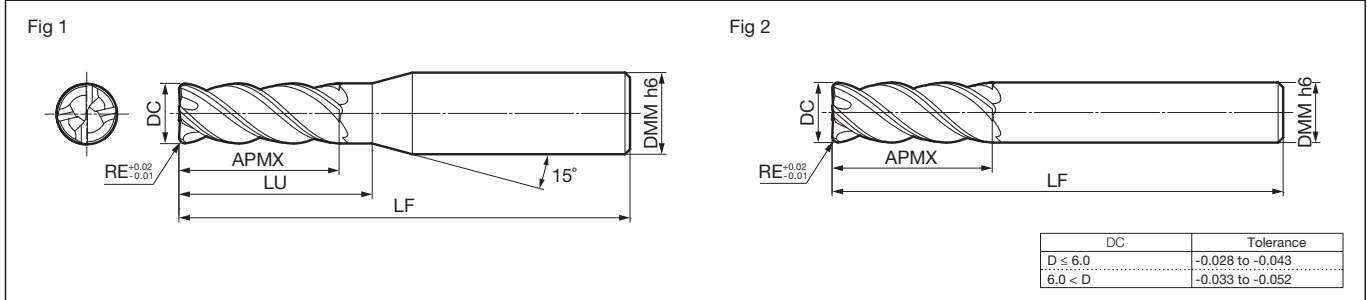

Body

Dimensions (mm)

Cat. No.	Stock	Dia. DC	Radius RE	Cutting Edge Length APMX	Neck Length LU	Overall Length LF	Shank Dia. DMM	Fig
SSEHVL 4045-R05	●	4.5	0.5	12.0	14.5	50	6	1
4045-R10	●	4.5	1.0	12.0	14.5	50	6	1
4050-R05	●	5.0	0.5	13.0	15.5	60	6	1
4050-R10	●	5.0	1.0	13.0	15.5	60	6	1
4060-R10	●	6.0	1.0	13.0	—	60	6	2
SSEHVL 4080-R10	●	8.0	1.0	19.0	—	80	8	2
4100-R10	●	10.0	1.0	22.0	—	90	10	2
4100-R30	●	10.0	3.0	22.0	—	90	10	2
4120-R10	●	12.0	1.0	26.0	—	90	12	2
4120-R30	●	12.0	3.0	26.0	—	90	12	2
SSEHVL 4160-R10	●	16.0	1.0	32.0	—	115	16	2
4160-R30	●	16.0	3.0	32.0	—	115	16	2

Grade: EH520

Square

Radius

Ballnose

Multi-Purpose

General-Purpose

High Efficiency

Hardened Steel

Roughing

Non-Ferrous Metal

CFRP

Coated

Uncoated

Recommended Cutting Conditions

1. For stable machining, a high-rigidity machine is recommended.
2. Wet machining is recommended for stainless steel and heat-resistant alloy applications.
3. If cutting noise and vibration are present, please change the cutting conditions accordingly.

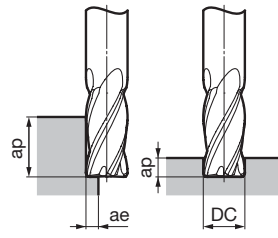

Side Milling

Work Material	Stainless Steel SUS304, SUS316		Titanium Alloy		Heat-Resistant Alloy	
	Spindle Speed (min ⁻¹)	Feed Rate (mm/min)	Spindle Speed (min ⁻¹)	Feed Rate (mm/min)	Spindle Speed (min ⁻¹)	Feed Rate (mm/min)
DC (mm) 4.5	2,300	120	4,600	370	1,600	130
5.0	2,000	130	4,100	410	1,500	150
6.0	1,700	130	3,400	400	1,200	140
8.0	1,300	130	2,600	360	900	130
10.0	1,000	130	2,100	340	700	110
12.0	800	110	1,700	300	600	100
16.0	600	90	1,300	260	500	100
Standard Depth of Cut	ap	1.5DC	1.5DC	1.5DC	1.5DC	1.5DC
pf	0.1DC	0.05DC	0.05DC	0.05DC	0.05DC	0.05DC

Groove Milling

Work Material	Stainless Steel SUS304, SUS316		Titanium Alloy		Heat-Resistant Alloy	
	Spindle Speed (min ⁻¹)	Feed Rate (mm/min)	Spindle Speed (min ⁻¹)	Feed Rate (mm/min)	Spindle Speed (min ⁻¹)	Feed Rate (mm/min)
DC (mm) 4.5	1,800	50	3,200	250	1,300	110
5.0	1,600	50	2,900	290	1,200	120
6.0	1,400	50	2,400	290	1,000	120
8.0	1,000	50	1,800	250	700	90
10.0	800	50	1,400	230	600	100
12.0	600	50	1,200	210	500	90
16.0	500	40	900	180	400	80
Standard Depth of Cut	ap	0.3DC	0.2DC	0.15DC	0.15DC	0.15DC

SSEH 4000-R type

Stainless Steel / Ti Alloy / Heat Resistant Alloy

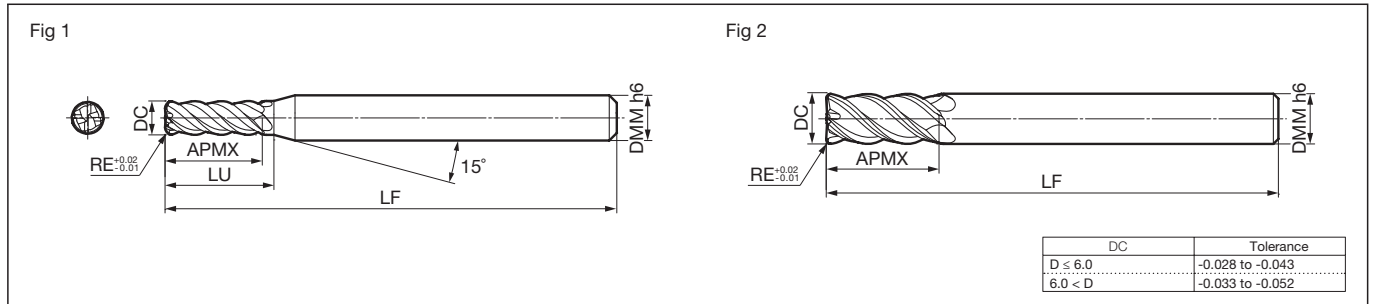
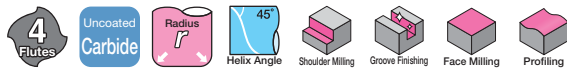

Body

Cat. No.	Stock	Dimensions (mm)						
		Dia. DC	Radius RE	Cutting Edge Length APMX	Neck Length LU	Overall Length LF	Shank Dia. DMM	Fig
SSEH 4045-R05	●	4.5	0.5	12.0	14.5	50	6	1
4050-R05	●	5.0	0.5	13.0	15.5	60	6	1
4060-R10	●	6.0	1.0	13.0	—	60	6	2
4080-R10	●	8.0	1.0	19.0	—	80	8	2
4100-R10	●	10.0	1.0	22.0	—	90	10	2
SSEH 4100-R30	●	10.0	3.0	22.0	—	90	10	2
4120-R10	●	12.0	1.0	26.0	—	90	12	2
4120-R30	●	12.0	3.0	26.0	—	90	12	2
4160-R10	●	16.0	1.0	32.0	—	115	16	2
4160-R30	●	16.0	3.0	32.0	—	115	16	2

Grade: EH520

Recommended Cutting Conditions

- For stable machining, a high-rigidity machine is recommended.
- Wet machining is recommended for stainless steel and heat-resistant alloy applications.
- If cutting noise and vibration are present, please change the cutting conditions accordingly.

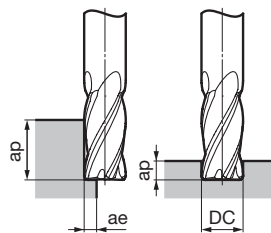

Side Milling

Work Material	Stainless Steel SUS304,SUS316		Titanium Alloy		Heat-Resistant Alloy	
	Spindle Speed (min ⁻¹)	Feed Rate (mm/min)	Spindle Speed (min ⁻¹)	Feed Rate (mm/min)	Spindle Speed (min ⁻¹)	Feed Rate (mm/min)
DC (mm)						
4.5	1,800	90	3,500	280	1,400	110
5.0	1,600	100	3,200	320	1,300	130
6.0	1,300	100	2,700	320	1,100	130
8.0	1,000	100	2,000	280	800	110
10.0	800	100	1,600	260	600	100
12.0	700	100	1,300	230	500	90
16.0	500	80	1,000	200	400	80
Standard Depth of Cut	ap	1.5DC	1.5DC	1.5DC	1.5DC	1.5DC
	ae	0.1DC	0.05DC	0.05DC	0.05DC	0.05DC

Groove Milling

Work Material	Stainless Steel SUS304,SUS316		Titanium Alloy		Heat-Resistant Alloy	
	Spindle Speed (min ⁻¹)	Feed Rate (mm/min)	Spindle Speed (min ⁻¹)	Feed Rate (mm/min)	Spindle Speed (min ⁻¹)	Feed Rate (mm/min)
DC (mm)						
4.5	1,400	40	2,500	200	1,100	90
5.0	1,300	40	2,200	220	1,000	100
6.0	1,100	40	1,900	230	800	100
8.0	800	40	1,400	200	600	80
10.0	600	40	1,100	180	500	80
12.0	500	40	900	160	400	70
16.0	400	30	700	140	300	60
Standard Depth of Cut	ap	0.3DC	0.2DC	0.15DC	0.15DC	0.15DC

Endmills

I

Square

Radius

Ballnose

Multi-Purpose

General-Purpose

High Efficiency

Hardened Steel

Roughing

Non-Ferrous Metal

CFRP

Coated

Uncoated

NPDRS type

Cemented Carbide Hard Brittle Material

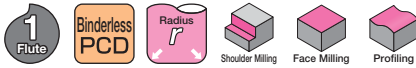

Endmills I

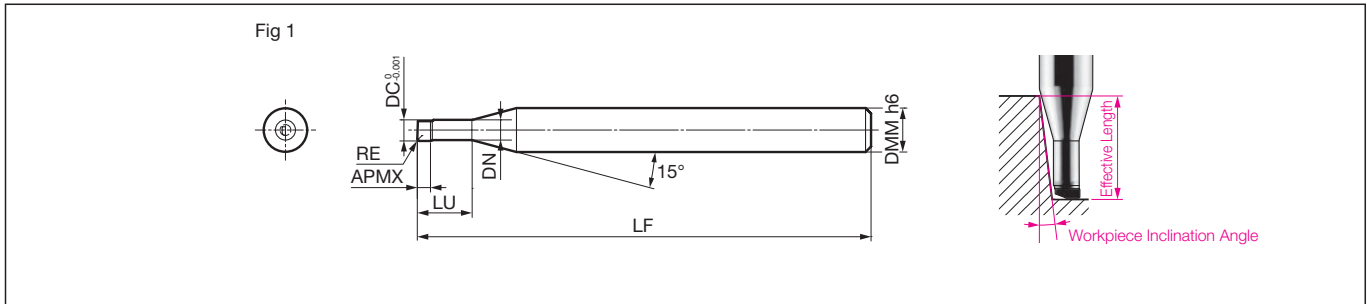

Body Dimensions (mm)

Cat. No.	Stock	Dia. DC	Corner Radius RE	Cutting Edge Length		Neck Length LU	Overall Length LF	Neck Dia. DN	Shank Dia. DMM	Effective Length for Workpiece Inclination Angle					Wiper Edge	Fig
				APMX	APMX					0.5°	1°	1.5°	2°	3°		
NPDRS 1020R002-006	●	0.2	0.02	0.1	0.1	0.6	40	0.175	4	0.63	0.65	0.67	0.70	0.75	No	1
1020R005-006	●	0.2	0.05	0.1	0.1	0.6	40	0.175	4	0.63	0.65	0.67	0.69	0.74	No	1
1030R002-010	●	0.3	0.02	0.15	0.15	1.0	40	0.27	4	1.04	1.08	1.11	1.15	1.24	No	1
1030R005-010	●	0.3	0.05	0.15	0.15	1.0	40	0.27	4	1.04	1.08	1.11	1.15	1.23	No	1
1050R005-015	●	0.5	0.05	0.25	0.25	1.5	40	0.47	4	1.56	1.61	1.66	1.72	1.84	No	1
NPDRS 1050R010-015	●	0.5	0.10	0.25	0.25	1.5	40	0.47	4	1.56	1.60	1.65	1.71	1.83	No	1
1100R005-030	●	1.0	0.05	0.55	0.55	3.0	40	0.95	4	3.14	3.24	3.35	3.46	3.72	No	1
1100R010-030	●	1.0	0.10	0.55	0.55	3.0	40	0.95	4	3.14	3.24	3.34	3.46	3.71	No	1
1100R020-030	●	1.0	0.20	0.55	0.55	3.0	40	0.95	4	3.14	3.23	3.33	3.44	3.69	No	1
1200R005-040	●	2.0	0.05	0.55	0.55	4.0	40	1.95	4	4.17	4.31	4.45	4.60	4.94	No	1
NPDRS 1200R010-040	●	2.0	0.10	0.55	0.55	4.0	40	1.95	4	4.17	4.30	4.44	4.60	4.93	No	1
1200R020-040	●	2.0	0.20	0.55	0.55	4.0	40	1.95	4	4.17	4.30	4.43	4.58	4.91	No	1

Grade: NPD10

Identification Code

NPDR S 1 020 R002 - 006

Series Code For No. of Dia. Corner Radius Neck Length
Standard Flutes Finishing

Recommended Cutting Conditions

1. Use a machine with high accuracy for stable cutting.
2. Non-water soluble coolant recommended. Supply as a mist or external coolant.
Take fire prevention precautions to avoid fire hazards caused by sparks igniting during machining or tool breakage.
3. Shorten overhang as much as possible.
4. Adjust cutting conditions as necessary as machine specs and other conditions may vary.
5. The cutting parameters shown are for reference only. Adjust the cutting conditions to the desired machined surface finish.

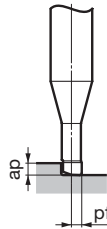

Work Material		Cemented Carbide			
DC (mm)	LU (mm)	Spindle Speed (min ⁻¹)	Feed Rate (mm/min)	ap(mm)	pf(mm)
0.2	0.6	40,000	100	0.001	0.001
0.3	1.0	40,000	150	0.002	0.001
0.5	1.5	40,000	200	0.003	0.001
1.0	3.0	40,000	400	0.005	0.003
2.0	4.0	40,000	600	0.010	0.005

Uncoated

MEMO

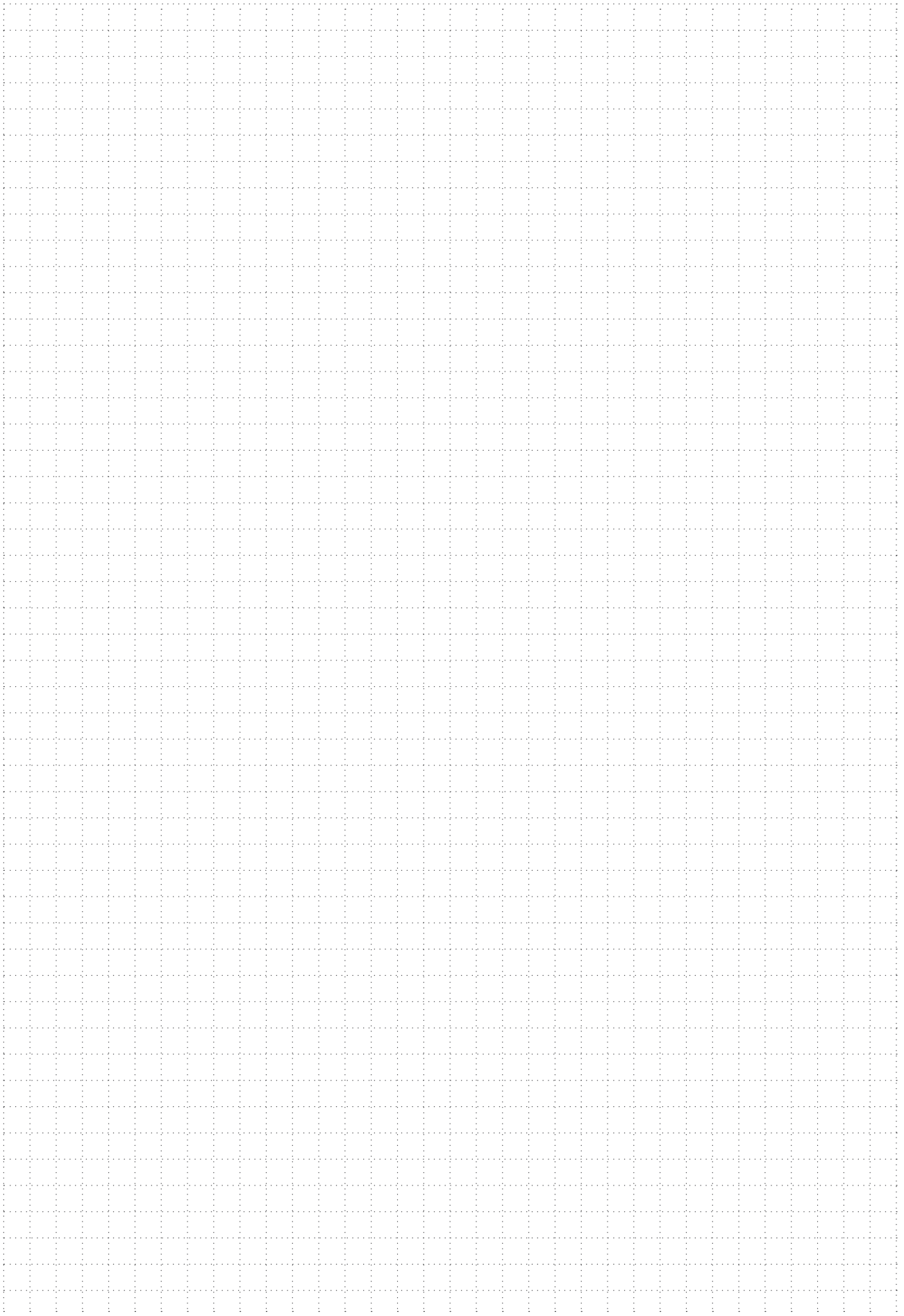

BNBR type

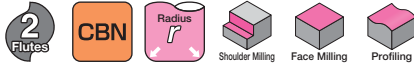
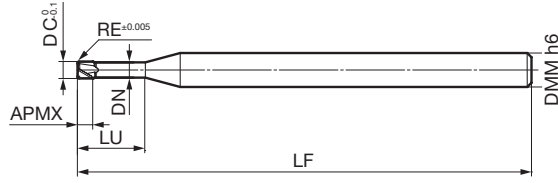

Fig 1



Body

Dimensions (mm)

Cat. No.	Stock	Dia. DC	Corner Radius RE	Cutting Edge Length APMX	Neck Length LU	Overall Length LF	Neck Dia. DN	Shank Dia. DMM	Wiper Edge	Fig
BNBR 2D020R005-0054	●	0.2	0.05	0.1	0.5	50	0.17	4	No	1
2D030R005-0054	●	0.3	0.05	0.15	0.5	50	0.27	4	No	1
2D040R005-0054	●	0.4	0.05	0.2	0.5	50	0.37	4	No	1
2D050R005-0054	●	0.5	0.05	0.3	0.5	50	0.47	4	No	1
2D050R005-0154	●	0.5	0.05	0.3	1.5	50	0.47	4	No	1
BNBR 2D050R005-0254	●	0.5	0.05	0.3	2.5	50	0.47	4	No	1
2D050R010-0154	●	0.5	0.10	0.3	1.5	50	0.47	4	No	1
2D050R010-0254	●	0.5	0.10	0.3	2.5	50	0.47	4	No	1
2D100R005-0304	●	1.0	0.05	0.7	3.0	50	0.97	4	Yes	1
2D100R005-0504	●	1.0	0.05	0.7	5.0	50	0.97	4	Yes	1
BNBR 2D100R010-0304	●	1.0	0.10	0.7	3.0	50	0.97	4	Yes	1
2D100R010-0504	●	1.0	0.10	0.7	5.0	50	0.97	4	Yes	1
2D100R020-0304	●	1.0	0.20	0.7	3.0	50	0.97	4	Yes	1
2D100R020-0504	●	1.0	0.20	0.7	5.0	50	0.97	4	Yes	1
2D100R030-0304	●	1.0	0.30	0.7	3.0	50	0.97	4	Yes	1
BNBR 2D100R030-0504	●	1.0	0.30	0.7	5.0	50	0.97	4	Yes	1
2D150R010-0454	●	1.5	0.10	1.2	4.5	50	1.47	4	Yes	1
2D150R010-0754	●	1.5	0.10	1.2	7.5	50	1.47	4	Yes	1
2D150R020-0454	●	1.5	0.20	1.2	4.5	50	1.47	4	Yes	1
2D150R020-0754	●	1.5	0.20	1.2	7.5	50	1.47	4	Yes	1
BNBR 2D150R030-0454	●	1.5	0.30	1.2	4.5	50	1.47	4	Yes	1
2D150R030-0754	●	1.5	0.30	1.2	7.5	50	1.47	4	Yes	1
2D200R010-0604	●	2.0	0.10	1.5	6.0	50	1.97	4	Yes	1
2D200R020-0604	●	2.0	0.20	1.5	6.0	50	1.97	4	Yes	1
2D200R030-0604	●	2.0	0.30	1.5	6.0	50	1.97	4	Yes	1
BNBR 2D200R050-0604	●	2.0	0.50	1.5	6.0	50	1.97	4	Yes	1

Grade: BNX20

Identification Code

BNBR 2 D050 R010 - 015 4

Series Code No. of Flutes Dia. Corner Radius Neck Length Shank Dia.

Endmills

I

Square

Radius

Ballnose

Multi-Purpose

General-Purpose

High Efficiency

Hardened Steel

Roughing

Non-Ferrous Metal

CFRP

Coated

Uncoated

BNBR type

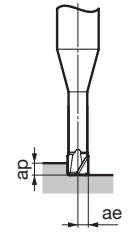

Recommended Cutting Conditions

1. Use a machine with high rigidity for stable cutting.
2. Non-water soluble cutting oil is recommended. Supply as a mist or external coolant.
Take fire prevention precautions to avoid fire hazards caused by sparks igniting during machining or tool breakage.
3. Shorten overhang as much as possible.
4. Adjust cutting conditions as necessary as machine rigidity and other conditions may vary.
5. Depths of cut shown in the table of conditions are maximum depths. Adjust the actual depth of cut to the desired machined surface roughness.

Work Material			STAVAX, NAK80, SKD61 (Up to 52HRC)				ELMAX, DC53, SKD11 Modified (Up to 62HRC)				YXR3, SKH (Up to 70HRC)			
DC (mm)	RE (mm)	LU (mm)	Spindle Speed (min ⁻¹)	Feed Rate (mm/min)	ap (mm)	ae (mm)	Spindle Speed (min ⁻¹)	Feed Rate (mm/min)	ap (mm)	ae (mm)	Spindle Speed (min ⁻¹)	Feed Rate (mm/min)	ap (mm)	ae (mm)
0.2	0.05	0.5	40,000	400	0.005	0.03	40,000	400	0.005	0.03	40,000	250	0.005	0.02
0.3	0.05	0.5	40,000	500	0.010	0.05	40,000	500	0.010	0.05	40,000	300	0.005	0.03
0.4	0.05	0.5	40,000	600	0.015	0.1	40,000	600	0.015	0.1	40,000	400	0.01	0.05
0.5	0.05	0.5	40,000	600	0.02	0.15	40,000	600	0.02	0.15	40,000	400	0.01	0.1
	0.05	1.5	40,000		0.02	0.1	40,000		0.02	0.1	35,000		0.01	0.05
	0.1	40,000	0.01		0.05	40,000	0.01		0.05	35,000				
	0.05	2.5	40,000		0.01	0.05	40,000		0.01	0.05	35,000			
1.0	0.05	3.0	35,000	800	0.03	0.3	35,000	800	0.03	0.2	30,000	600	0.01	0.1
	0.1		35,000				35,000				30,000			
	0.2		35,000				35,000				30,000			
	0.3		35,000				35,000				30,000			
	0.05	5.0	35,000		0.02	0.2	35,000	800	0.02	0.1	30,000	600	0.01	0.1
1.5	0.1	4.5	26,000	800	0.03	0.5	26,000	800	0.03	0.3	20,000	600	0.02	0.3
	0.2		26,000				26,000				20,000			
	0.3		26,000				26,000				20,000			
	0.1	7.5	26,000		0.03	0.5	26,000	800	0.03	0.3	20,000	600	0.02	0.3
	0.2	26,000	0.03		0.5	26,000	800	0.03	0.3	20,000				
0.3	26,000	0.03	0.5	26,000	800	0.03	0.3	20,000						
2.0	0.1	6.0	20,000	800	0.03	0.7	20,000	800	0.03	0.7	15,000	600	0.03	0.7
	0.2		20,000				20,000				15,000			
	0.3		20,000				20,000				15,000			
	0.5		20,000				20,000				15,000			

Endmills



Square



Radius



Ballnose



Multi-Purpose



General-Purpose



High Efficiency



Hardened Steel



Roughing

Non-Ferrous Metal

CFRP

Coated

Uncoated

GSXB 20000 type

- General Steel
- Carbon Steel
- Alloy Steel
- Pre-hardened Steel
- Tempered Steel / Die Steel
- Hardened Steel 45 to 55HRC
- Hardened Steel 55 to 60HRC
- Stainless Steel
- Ti Alloy Heat Resistant Alloy
- Cast Iron

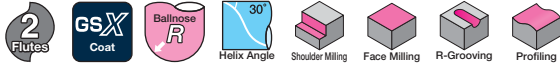

Endmills I

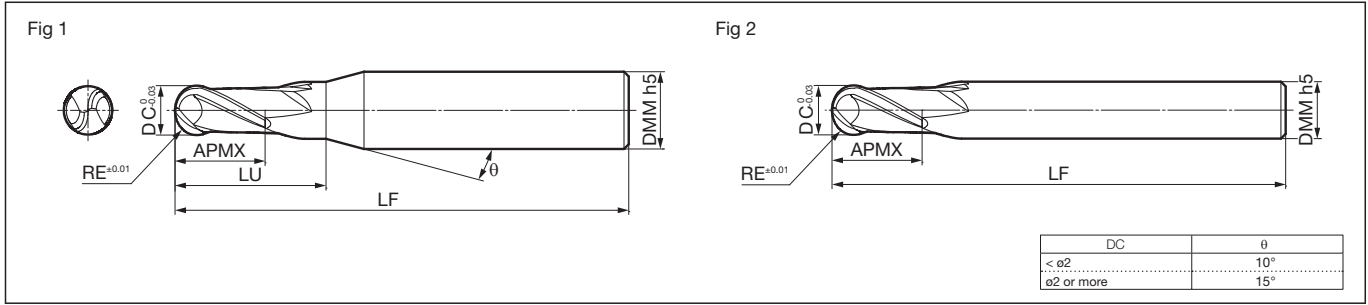

Body

Dimensions (mm)

Cat. No.	Stock	Ballnose Radius RE	Dia. DC	Cutting Edge Length APMX	Neck Length LU	Overall Length LF	Shank Dia. DMM	Fig
GSXB 20020	●	0.20	0.4	0.6	0.8	50	4	1
20030	●	0.30	0.6	0.9	1.2	50	4	1
20050	●	0.50	1.0	1.5	2.0	50	4	1
20075	●	0.75	1.5	2.5	3.0	50	4	1
20100	●	1.00	2.0	3.0	4.0	60	6	1
GSXB 20125	●	1.25	2.5	4.0	5.0	60	6	1
20150	●	1.50	3.0	4.5	6.0	60	6	1
20200	●	2.00	4.0	6.0	8.0	70	6	1
20250	●	2.50	5.0	7.5	10.0	80	6	1
20300	●	3.00	6.0	9.0	—	80	6	2
GSXB 20350	●	3.50	7.0	11.0	20.0	90	8	1
20400	●	4.00	8.0	12.0	—	90	8	2
20500	●	5.00	10.0	15.0	—	100	10	2
20600	●	6.00	12.0	18.0	—	110	12	2
20700	●	7.00	14.0	21.0	38.0	110	16	1
GSXB 20800	●	8.00	16.0	24.0	—	140	16	2
20900	●	9.00	18.0	27.0	50.0	140	20	1
21000	●	10.00	20.0	30.0	—	160	20	2

Grade: ACB20

Square

Radius

Ballnose

Multi-Purpose

General-Purpose

High Efficiency

Hardened Steel

Roughing

Non-Ferrous Metal

CFRP

Coated

Uncoated

GSXB 20000 type

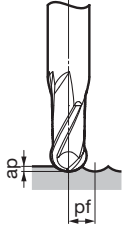

Recommended Cutting Conditions

1. If cutting noise and vibration occur, please reduce the cutting conditions accordingly.
2. If the machine cannot achieve the recommended spindle speed, please use the maximum spindle speed available.

Radius Milling

Work Material	Carbon Steel / Alloy Steel (Below 25HRC)		Carbon Steel / Alloy Steel (Below 50HRC)		Cast Iron Special Cast Iron		Stainless Steel Titanium Alloy		
	Spindle Speed (min ⁻¹)	Feed Rate (mm/min)	Spindle Speed (min ⁻¹)	Feed Rate (mm/min)	Spindle Speed (min ⁻¹)	Feed Rate (mm/min)	Spindle Speed (min ⁻¹)	Feed Rate (mm/min)	
0.20	50,000	2,100	35,000	1,150	50,000	2,100	50,000	1,750	
0.30	50,000	2,500	35,000	1,350	50,000	2,500	50,000	2,100	
0.50	50,000	3,000	35,000	1,600	50,000	3,000	50,000	2,500	
0.75	35,000	3,000	24,000	1,650	35,000	3,200	34,000	2,500	
1.00	27,500	3,000	19,000	1,700	35,000	3,900	26,000	2,500	
1.25	22,500	3,000	15,500	1,700	28,000	3,900	21,000	2,500	
1.50	19,000	3,000	13,000	1,700	24,000	3,900	17,500	2,500	
2.00	17,000	3,800	12,000	2,100	20,000	4,100	15,000	2,700	
2.50	15,500	4,300	11,000	2,200	18,000	4,600	12,000	2,500	
3.00	14,000	4,700	10,500	2,500	16,500	5,300	10,500	2,500	
3.50	12,500	4,200	9,000	2,100	14,000	4,500	9,000	2,200	
4.00	11,000	3,500	7,900	1,900	12,500	4,000	7,800	1,900	
5.00	9,000	2,800	6,300	1,500	10,500	3,300	6,300	1,500	
6.00	7,500	2,400	5,200	1,250	8,700	2,800	5,200	1,250	
7.00	6,400	2,100	4,500	1,100	7,400	2,400	4,500	1,100	
8.00	5,600	1,800	3,900	950	6,500	2,100	3,900	950	
9.00	5,000	1,600	3,500	850	5,800	1,900	3,500	850	
10.00	4,500	1,450	3,100	750	5,200	1,700	3,150	750	
Standard Depth of Cut	ap	0.02DC		0.02DC		0.02DC		0.02DC	
	pf	0.05DC		0.05DC		0.05DC		0.05DC	

Endmills

I

Square

Radius

Ballnose

Multi-Purpose

General-Purpose

High Efficiency

Hardened Steel

Roughing

Non-Ferrous Metal

CFRP

Coated

Uncoated

GSBH 20000SF type

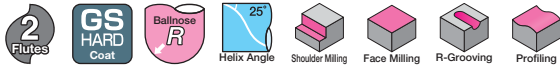

Endmills

I

Square

Radius

Ballnose

Multi-Purpose

General-Purpose

High Efficiency

Hardened Steel

Roughing

Non-Ferrous Metal

CFRP

Coated

Uncoated

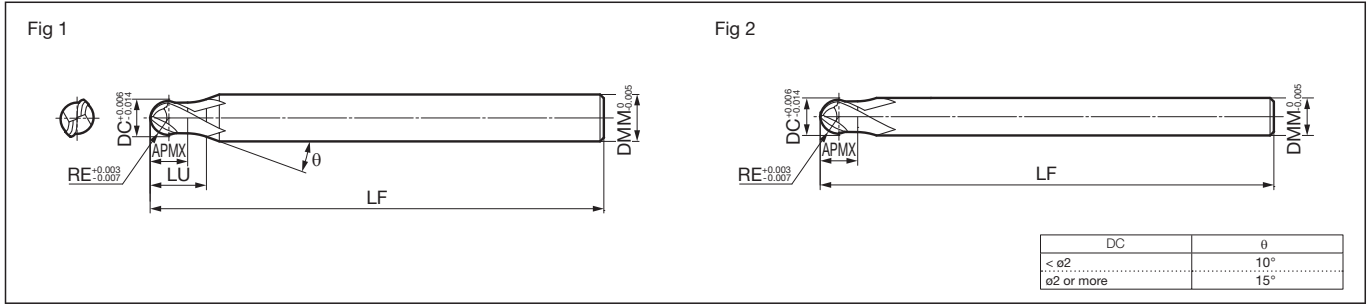

Body Dimensions (mm)

Cat. No.	Stock	Ballnose Radius RE	Dia. DC	Cutting Edge Length APMX	Neck Length LU	Overall Length LF	Shank Dia. DMM	Fig
GSBH 20020SF	●	0.20	0.4	0.4	0.6	50	4	1
20030SF	●	0.30	0.6	0.6	0.9	50	4	1
20050SF	●	0.50	1.0	1.0	1.5	50	4	1
20075SF	●	0.75	1.5	1.5	2.3	50	4	1
20100SF	●	1.00	2.0	2.0	3.0	60	6	1
GSBH 20125SF	●	1.25	2.5	2.5	3.8	60	6	1
20150SF	●	1.50	3.0	3.0	4.5	60	6	1
20200SF	●	2.00	4.0	4.0	6.0	70	6	1
20250SF	●	2.50	5.0	5.0	7.5	80	6	1
20300SF	●	3.00	6.0	6.0	—	80	6	2
GSBH 20400SF	●	4.00	8.0	8.0	—	90	8	2
20500SF	●	5.00	10.0	10.0	—	100	10	2
20600SF	●	6.00	12.0	12.0	—	110	12	2

Grade: ACF07D

Recommended Cutting Conditions

- When the depth of cut is lowered, feed rate can be increased further.
- If the machine is not suited to the recommended spindle speed, please use the maximum spindle speed available. In this case, lower the feed rate by the same ratio.
- If cutting noise and vibration occur, please reduce the cutting conditions accordingly.

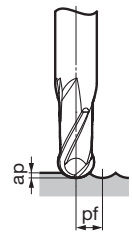

Radius Milling

Work Material	Medium Hardened Steel Pre-hardened Steel, Die Steel (40 to 50HRC)		Hardened Steel SKD61 (50 to 55HRC)		Hardened Steel SKD11 (55 to 60HRC)		Hardened Steel SKH55 (60 to 65HRC)		
	RE (mm)	Spindle Speed (min ⁻¹)	Feed Rate (mm/min)	Spindle Speed (min ⁻¹)	Feed Rate (mm/min)	Spindle Speed (min ⁻¹)	Feed Rate (mm/min)	Spindle Speed (min ⁻¹)	Feed Rate (mm/min)
0.20	50,000	500	50,000	500	50,000	500	50,000	500	
0.30	50,000	800	50,000	800	50,000	800	50,000	700	
0.50	50,000	1,400	50,000	1,400	50,000	1,300	42,000	1,000	
0.75	50,000	2,000	50,000	2,000	37,300	1,400	28,000	1,000	
1.00	38,100	2,100	38,100	2,100	28,000	1,400	21,000	1,000	
1.25	30,500	2,100	30,500	2,100	22,400	1,400	16,800	1,000	
1.50	25,400	2,100	25,400	2,100	18,700	1,400	14,000	1,000	
2.00	19,100	2,100	19,100	2,100	14,000	1,400	10,500	1,000	
2.50	15,300	2,100	15,300	2,100	11,200	1,400	8,400	1,000	
3.00	12,700	2,100	12,700	2,100	9,300	1,400	7,000	1,000	
4.00	9,500	2,100	9,500	2,100	7,000	1,400	5,300	1,000	
5.00	7,600	2,100	7,600	2,100	5,600	1,400	4,200	1,000	
6.00	6,400	2,100	6,400	2,100	4,700	1,400	3,500	1,000	
Standard Depth of Cut	ap	0.08DC				0.05DC			
	pf	0.25DC				0.15DC			

SNB 2000DL type

Aluminum Alloy
Copper Alloy

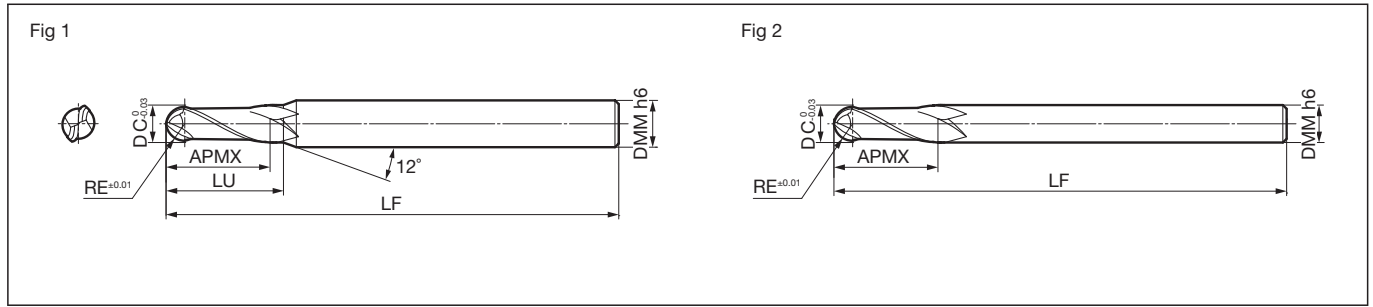

Body

Cat. No.	Stock	Dimensions (mm)						
		Ballnose Radius RE	Dia. DC	Cutting Edge Length APMX	Neck Length LU	Overall Length LF	Shank Dia. DMM	Fig
SNB 2020DL	●	1.0	2.0	3.0	5	60	6	1
2030DL	●	1.5	3.0	4.5	8	80	6	1
2040DL	●	2.0	4.0	6.0	12	80	6	1
2050DL	●	2.5	5.0	7.5	14	90	6	1
2060DL	●	3.0	6.0	9.0	—	100	6	2
SNB 2080DL	●	4.0	8.0	12.0	—	100	8	2
2100DL	●	5.0	10.0	15.0	—	120	10	2
2120DL	●	6.0	12.0	18.0	—	120	12	2
2160DL	●	8.0	16.0	24.0	—	160	16	2

Grade: DL1200

Recommended Cutting Conditions

1. If the machine cannot achieve the recommended spindle speed, please use the maximum spindle speed available.
2. If cutting noise and vibration occur, please reduce the cutting conditions accordingly.

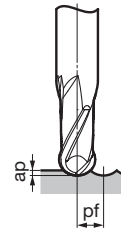

Radius Milling

Work Material	Aluminum Alloy			
	Wet		Dry	
	Spindle Speed (min ⁻¹)	Feed Rate (mm/min)	Spindle Speed (min ⁻¹)	Feed Rate (mm/min)
RE (mm)				
1.0	48,000	1,500	48,000	1,000
1.5	38,000	2,100	38,000	1,500
2.0	31,000	2,800	31,000	2,000
2.5	24,000	2,800	24,000	2,000
3.0	20,000	2,800	20,000	2,000
4.0	15,000	2,800	15,000	2,000
5.0	13,000	3,000	13,000	2,100
6.0	10,000	3,000	10,000	2,100
8.0	7,700	3,000	7,700	2,100
Standard Depth of Cut	ap	0.1DC	0.1DC	
	pf	0.2DC	0.2DC	

Endmills

I

Square

Radius

Ballnose

Multi-Purpose

General-Purpose

High Efficiency

Hardened Steel

Roughing

Non-Ferrous Metal

CFRP

Coated

Uncoated

SNB2 type

Aluminum Alloy
Copper Alloy



Fig 1

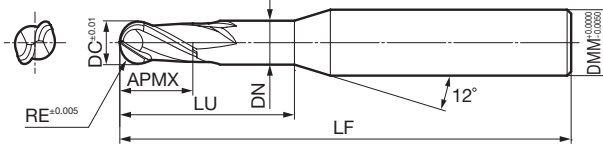

Body Dimensions (mm)

Cat. No.	Stock	Ballnose Radius RE	Dia. DC	Cutting Edge Length APMX	Neck Length LU	Overall Length LF	Neck Dia. DN	Shank Dia. DMM	Fig
SNB2 0005 0034DL	●	0.05	0.1	0.1	0.3	45	0.09	4	1
0005 0064DL	●	0.05	0.1	0.1	0.6	45	0.09	4	1
0010 0054DL	●	0.10	0.2	0.2	0.5	45	0.18	4	1
0010 0104DL	●	0.10	0.2	0.2	1.0	45	0.18	4	1
0010 0204DL	●	0.10	0.2	0.2	2.0	45	0.18	4	1
SNB2 0015 0054DL	●	0.15	0.3	0.3	0.5	45	0.27	4	1
0015 0104DL	●	0.15	0.3	0.3	1.0	45	0.27	4	1
0015 0204DL	●	0.15	0.3	0.3	2.0	45	0.27	4	1
0015 0304DL	●	0.15	0.3	0.3	3.0	45	0.27	4	1
0020 0104DL	●	0.20	0.4	0.4	1.0	45	0.36	4	1
SNB2 0020 0204DL	●	0.20	0.4	0.4	2.0	45	0.36	4	1
0020 0304DL	●	0.20	0.4	0.4	3.0	45	0.36	4	1
0020 0404DL	●	0.20	0.4	0.4	4.0	45	0.36	4	1
0025 0104DL	●	0.25	0.5	0.45	1.0	45	0.45	4	1
0025 0204DL	●	0.25	0.5	0.45	2.0	45	0.45	4	1
SNB2 0025 0304DL	●	0.25	0.5	0.45	3.0	45	0.45	4	1
0025 0404DL	●	0.25	0.5	0.45	4.0	45	0.45	4	1
0030 0204DL	●	0.30	0.6	0.6	2.0	45	0.54	4	1
0030 0304DL	●	0.30	0.6	0.6	3.0	45	0.54	4	1
0030 0404DL	●	0.30	0.6	0.6	4.0	45	0.54	4	1
SNB2 0030 0504DL	●	0.30	0.6	0.6	5.0	45	0.54	4	1
0030 0604DL	●	0.30	0.6	0.6	6.0	45	0.54	4	1
0050 0304DL	●	0.50	1.0	1.5	3.0	45	0.90	4	1
0050 0404DL	●	0.50	1.0	1.5	4.0	45	0.90	4	1
0050 0604DL	●	0.50	1.0	1.5	6.0	45	0.90	4	1
SNB2 0050 0804DL	●	0.50	1.0	1.5	8.0	50	0.90	4	1
0050 1004DL	●	0.50	1.0	1.5	10.0	50	0.90	4	1
0075 0304DL	●	0.75	1.5	2.3	3.0	45	1.35	4	1
0075 0604DL	●	0.75	1.5	2.3	6.0	45	1.35	4	1
0075 1004DL	●	0.75	1.5	2.3	10.0	50	1.35	4	1
SNB2 0100 0304DL	●	1.00	2.0	3.0	3.0	50	1.80	4	1
0100 0604DL	●	1.00	2.0	3.0	6.0	50	1.80	4	1
0100 1004DL	●	1.00	2.0	3.0	10.0	50	1.80	4	1
0100 1504DL	●	1.00	2.0	3.0	15.0	60	1.80	4	1
0100 2004DL	●	1.00	2.0	3.0	20.0	60	1.80	4	1
SNB2 0200 1606DL	●	2.00	4.0	6.0	16.0	80	3.60	6	1
0200 2006DL	●	2.00	4.0	6.0	20.0	80	3.60	6	1
0200 3006DL	●	2.00	4.0	6.0	30.0	80	3.60	6	1

Grade: DL1200

Endmills

I

Square

Radius

Ballnose

Multi-Purpose

General-Purpose

High Efficiency

Hardened Steel

Roughing

Non-Ferrous Metal

CFRP

Coated

Uncoated

SNB2 type

Recommended Cutting Conditions

1. For radius processing, reduce the feed to half the recommended feed.
2. Insoluble cutting oil is recommended.
3. Because of the high spindle speeds, runout of the endmill when mounted should be less than 10 µm.

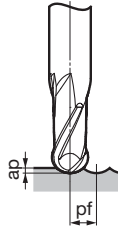

Radius Milling

Work Material	Copper Alloy			
	Spindle Speed (min ⁻¹)	Feed Rate (mm/min)	Standard depth of cut (mm)	
Cat. No.			ap	ae
SNB2 0005 0034DL	20,000	90	0.005	0.005
0005 0064DL	-50,000	80	0.005	0.005
SNB2 0010 0054DL	20,000 -50,000	350	0.01	0.02
0010 0104DL		350	0.007	0.015
0010 0204DL		200	0.005	0.005
SNB2 0015 0054DL	20,000 -50,000	400	0.015	0.025
0015 0104DL		400	0.01	0.02
0015 0204DL		300	0.007	0.01
0015 0304DL		250	0.005	0.008
SNB2 0020 0104DL	20,000 -30,000	800	0.025	0.05
0020 0204DL		700	0.02	0.03
0020 0304DL		600	0.015	0.02
0020 0404DL		400	0.007	0.015
SNB2 0025 0104DL	20,000 -30,000	1,000	0.04	0.07
0025 0204DL		800	0.03	0.06
0025 0304DL		700	0.02	0.05
0025 0404DL		600	0.015	0.04
SNB2 0030 0204DL	20,000 -30,000	1,400	0.05	0.15
0030 0304DL		1,200	0.04	0.1
0030 0404DL		1,000	0.03	0.07
0030 0504DL		700	0.03	0.06
0030 0604DL		600	0.015	0.03
SNB2 0050 0304DL	20,000 -30,000	3,500	0.2	0.4
0050 0404DL		3,000	0.15	0.4
0050 0604DL		2,500	0.13	0.3
0050 0804DL		2,000	0.07	0.15
0050 1004DL		1,200	0.04	0.07
SNB2 0075 0304DL	20,000	4,000	0.25	0.4
0075 0604DL	20,000	3,200	0.15	0.4
0075 1004DL	20,000	2,000	0.1	0.3
SNB2 0100 0304DL	16,000	4,500	0.4	0.6
0100 0604DL	16,000	3,500	0.35	0.6
0100 1004DL	16,000	3,000	0.25	0.4
0100 1504DL	12,000	2,000	0.15	0.3
0100 2004DL	10,000	1,500	0.1	0.2
SNB2 0200 1606DL	16,000	4,000	0.4	0.8
0200 2006DL	16,000	3,500	0.4	0.8
0200 3006DL	12,000	3,000	0.2	0.4

NPDBS type

Cemented Carbide Hard Brittle Material



Endmills

I

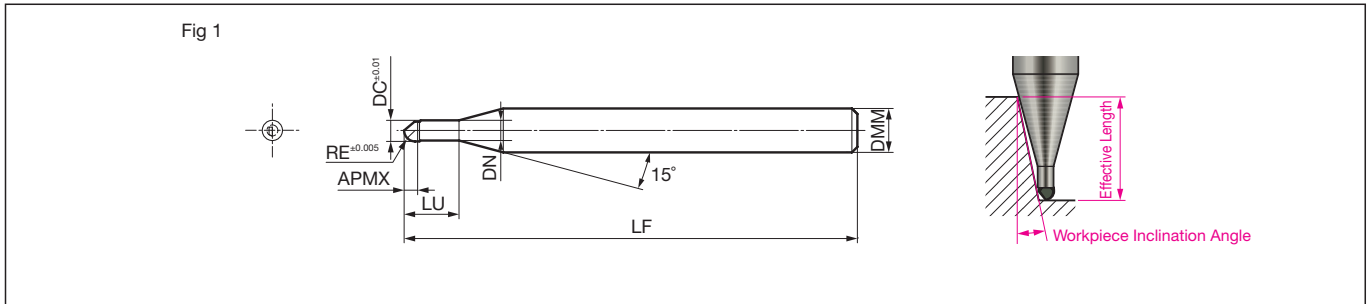

Body (for Standard Finishing)

Dimensions (mm)

Cat. No.	Stock	Ballnose Radius RE	Dia. DC	Cutting Edge Length APMX	Neck Length LU	Overall Length LF	Neck Dia. DN	Shank Dia. DMM	Effective Length for Workpiece Inclination Angle					Fig
									0.5°	1°	1.5°	2°	3°	
NPDBS 1010-004	●	0.1	0.2	0.1	0.4	40	0.18	4	0.42	0.43	0.44	0.46	0.48	1
1020-008	●	0.2	0.4	0.2	0.8	40	0.38	4	0.83	0.85	0.87	0.90	0.95	1
1030-010	●	0.3	0.6	0.3	1.0	40	0.58	4	1.03	1.06	1.08	1.11	1.17	1
1050-020	●	0.5	1.0	0.5	2.0	40	0.95	4	2.10	2.15	2.20	2.26	2.39	1
1100-030	●	1.0	2.0	1.0	3.0	40	1.95	4	3.11	3.18	3.25	3.33	3.51	1

Grade: NPD10

Square

Radius

Identification Code

NPDB S 1 010 - 004

Series Code	For Standard Finishing	No. of Flutes	Ballnose Radius	Neck Length
-------------	------------------------	---------------	-----------------	-------------

Ballnose

Multi-Purpose

Recommended Cutting Conditions

1. Use a machine with high accuracy for stable cutting.
2. Non-water soluble coolant recommended. Supply as a mist or external coolant.
Take fire prevention precautions to avoid fire hazards caused by sparks igniting during machining or tool breakage.
3. Shorten overhang as much as possible.
4. Adjust cutting conditions as necessary as machine specs and other conditions may vary.
5. The cutting parameters shown are for reference only. Adjust the cutting conditions to the desired machined surface finish.

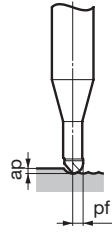

General-Purpose

High Efficiency

Work Material		Cemented Carbide			
RE (mm)	LU (mm)	Spindle Speed (min ⁻¹)	Feed Rate (mm/min)	ap(mm)	pf(mm)
0.1	0.4	40,000	100	0.001	0.001
0.2	0.8	40,000	150	0.002	0.001
0.3	1.0	40,000	200	0.003	0.001
0.5	2.0	40,000	400	0.005	0.003
1.0	3.0	40,000	600	0.010	0.005

Hardened Steel

Roughing

Non-Ferrous Metal

CFRP

Coated

Uncoated

* Radius accuracy inspection report is included inside the case. I135
* Long neck type is also available depending on the size. Please consult us separately.

NPDB type

Cemented Carbide Hard Brittle Material

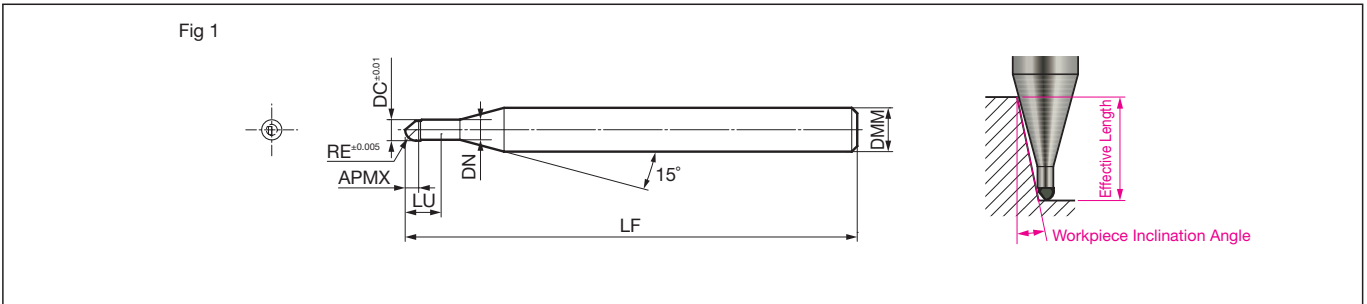

Body (for Precise Finishing)

Dimensions (mm)

Cat. No.	Stock	Ballnose Radius RE	Dia. DC	Cutting Edge Length APMX	Neck Length LU	Overall Length LF	Neck Dia. DN	Shank Dia. DMM	Effective Length for Workpiece Inclination Angle					Fig
									0.5°	1°	1.5°	2°	3°	
NPDB 1010-004	●	0.1	0.2	0.1	0.4	40	0.18	4	0.42	0.43	0.44	0.46	0.48	1
1020-008	●	0.2	0.4	0.2	0.8	40	0.38	4	0.83	0.85	0.87	0.90	0.95	1
1030-010	●	0.3	0.6	0.3	1.0	40	0.58	4	1.03	1.06	1.08	1.11	1.17	1
1050-020	●	0.5	1.0	0.5	2.0	40	0.95	4	2.10	2.15	2.20	2.26	2.39	1
1100-030	●	1.0	2.0	1.0	3.0	40	1.95	4	3.11	3.18	3.25	3.33	3.51	1

Grade: NPD10

Identification Code

NPDB 1 010 - 004

Series Code No. of Flutes Ballnose Radius Neck Length

Recommended Cutting Conditions

1. Use a machine with high accuracy for stable cutting.
2. Non-water soluble coolant recommended. Supply as a mist or external coolant.
Take fire prevention precautions to avoid fire hazards caused by sparks igniting during machining or tool breakage.
3. Shorten overhang as much as possible.
4. Adjust cutting conditions as necessary as machine specs and other conditions may vary.
5. The cutting parameters shown are for reference only. Adjust the cutting conditions to the desired machined surface finish.

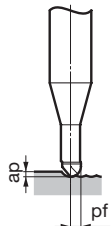

Work Material		Cemented Carbide			
RE (mm)	LU (mm)	Spindle Speed (min ⁻¹)	Feed Rate (mm/min)	ap (mm)	pf (mm)
0.1	0.4	40,000	100	0.001	0.001
0.2	0.8	40,000	150	0.002	0.001
0.3	1.0	40,000	200	0.003	0.001
0.5	2.0	40,000	400	0.005	0.003
1.0	3.0	40,000	600	0.010	0.005

* Radius accuracy inspection report is included inside the case. I135
 * Long neck type is also available depending on the size. Please consult us separately.

Endmills
I
Square
Radius
Ballnose
Multi-Purpose
General-Purpose
High Efficiency
Hardened Steel
Roughing
Non-Ferrous Metal
CFRP
Coated
Uncoated

SDCB type

Cemented Carbide Hard Brittle Material



Fig 1

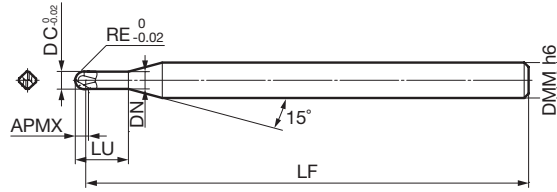

Body (For Rough/Medium-Finishing)

Dimensions (mm)

Cat. No.	Stock	Ballnose Radius RE	Dia. DC	Cutting Edge Length APMX	Neck Length LU	Overall Length LF	Neck Dia. DN	Shank Dia. DMM	Fig
SDCB 2R050-015	●	0.5	1.0	0.6	1.5	50	0.94	4	1
2R050-020	●	0.5	1.0	0.6	2.0	50	0.94	4	1
2R050-030	●	0.5	1.0	0.6	3.0	50	0.94	4	1
2R050-050	●	0.5	1.0	0.6	5.0	50	0.94	4	1
SDCB 2R100-025	●	1.0	2.0	1.4	2.5	50	1.92	4	1
2R100-040	●	1.0	2.0	1.4	4.0	50	1.92	4	1
2R100-060	●	1.0	2.0	1.4	6.0	50	1.92	4	1
2R100-100	●	1.0	2.0	1.4	10.0	50	1.92	4	1

Grade: DCM20

Identification Code

SDCB 2 R050 - 015

Series Code No. of Flutes Ballnose Radius Neck Length

Recommended Cutting Conditions

1. Use a machine with high accuracy for stable cutting.
2. Air blow is recommended, but oil mist or external coolant supply can also be used. Take fire prevention precautions to avoid fire hazards caused by sparks igniting during machining or tool breakage.
3. Shorten overhang as much as possible.
4. Adjust cutting conditions as necessary as machine specs and other conditions may vary.
5. The cutting parameters shown are for reference only. Adjust the cutting conditions to the desired machined surface finish.

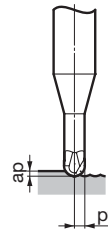

Work Material		Cemented Carbide			
RE (mm)	LU (mm)	Spindle Speed (min ⁻¹)	Feed Rate (mm/min)	ap (mm)	pf (mm)
0.5	1.5	30,000	300	0.05	0.25
1.0	2.5	30,000	300	0.10	0.30

Endmills I

Square

Radius

Ballnose

Multi-Purpose

General-Purpose

High Efficiency

Hardened Steel

Roughing

Non-Ferrous Metal

CFRP

Coated

Uncoated

MEMO

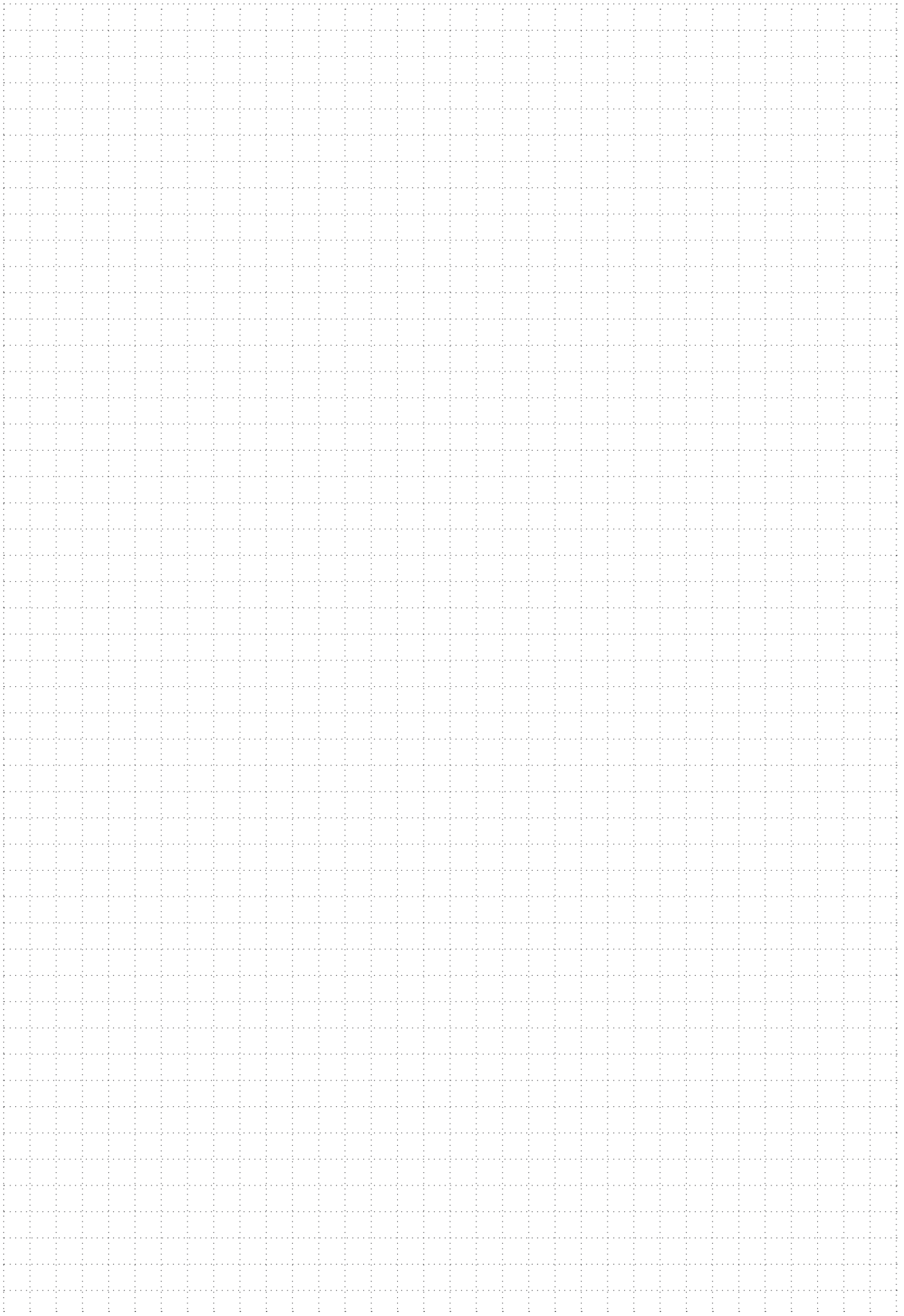

BNBP type



Fig 1

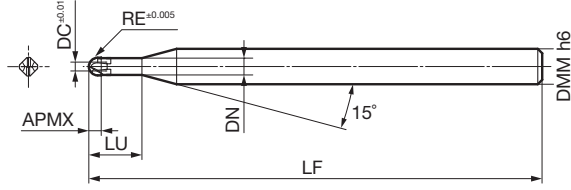

Body

Dimensions (mm)

Cat. No.	Stock	Ballnose Radius RE	Dia. DC	Cutting Edge Length APMX	Neck Length LU	Overall Length LF	Neck Dia. DN	Shank Dia. DMM	Fig
BNBP 2R020-0124	●	0.20	0.4	0.3	1.2	50	0.37	4	1
2R020-0126	●	0.20	0.4	0.3	1.2	50	0.37	6	1
2R020-0204	●	0.20	0.4	0.3	2.0	50	0.37	4	1
2R020-0304	●	0.20	0.4	0.3	3.0	50	0.37	4	1
2R020-0404	●	0.20	0.4	0.3	4.0	50	0.37	4	1
BNBP 2R030-0154	●	0.30	0.6	0.4	1.5	50	0.57	4	1
2R030-0156	●	0.30	0.6	0.4	1.5	50	0.57	6	1
2R030-0204	●	0.30	0.6	0.4	1.5	50	0.57	4	1
2R030-0304	●	0.30	0.6	0.4	3.0	50	0.57	4	1
2R030-0404	●	0.30	0.6	0.4	4.0	50	0.57	4	1
BNBP 2R030-0504	●	0.30	0.6	0.4	5.0	50	0.57	4	1
2R030-0604	●	0.30	0.6	0.4	6.0	50	0.57	4	1
2R050-0254	●	0.50	1.0	0.6	2.5	50	0.97	4	1
2R050-0256	●	0.50	1.0	0.6	2.5	50	0.97	6	1
2R050-0304	●	0.50	1.0	0.6	3.0	50	0.97	4	1
BNBP 2R050-0404	●	0.50	1.0	0.6	4.0	50	0.97	4	1
2R050-0604	●	0.50	1.0	0.6	6.0	50	0.97	4	1
2R050-0804	●	0.50	1.0	0.6	8.0	50	0.97	4	1
2R075-0404	●	0.75	1.5	0.9	4.0	50	1.47	4	1
2R075-0406	●	0.75	1.5	0.9	4.0	50	1.47	6	1
BNBP 2R100-0554	●	1.00	2.0	1.4	5.5	50	1.97	4	1
2R100-0556	●	1.00	2.0	1.4	5.5	50	1.97	6	1
2R100-0804	●	1.00	2.0	1.4	8.0	50	1.97	4	1

Grade: BN350

Identification Code

BNBP 2 R030 - 015 4

Series Code No. of Flutes Ballnose Radius Neck Length Shank Dia.

- Endmills
- I
- Square
- Radius
- Ballnose
- Multi-Purpose
- General-Purpose
- High Efficiency
- Hardened Steel
- Roughing
- Non-Ferrous Metal
- CFRP
- Coated
- Uncoated

BNBP type

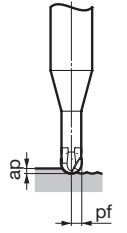

Recommended Cutting Conditions

1. Use a machine with high rigidity for stable cutting.
2. Non-water soluble cutting oil is recommended. Supply as a mist or external coolant.
Take fire prevention precautions to avoid fire hazards caused by sparks igniting during machining or tool breakage.
3. Shorten overhang as much as possible.
4. Adjust cutting conditions as necessary as machine rigidity and other conditions may vary.
5. Depths of cut shown in the table of conditions are maximum depths. Adjust the actual depth of cut to the desired machined surface roughness.

Work Material		STAVAX, NAK80, SKD61 (Up to 52HRC)				ELMAX, DC53, SKD11 Modified (Up to 62HRC)				YXR3, SKH (Up to 70HRC)			
RE (mm)	LU (mm)	Spindle Speed (min ⁻¹)	Feed Rate (mm/min)	ap (mm)	pf (mm)	Spindle Speed (min ⁻¹)	Feed Rate (mm/min)	ap (mm)	pf (mm)	Spindle Speed (min ⁻¹)	Feed Rate (mm/min)	ap (mm)	pf (mm)
0.2	1.2	40,000	1,000	0.005	0.010	40,000	800	0.005	0.010	40,000	600	0.005	0.005
	2.0	40,000	800	0.005	0.010	40,000	600	0.005	0.010	40,000	400	0.005	0.005
	3.0	40,000	600	0.005	0.010	40,000	500	0.005	0.010	40,000	300	0.005	0.005
	4.0	40,000	500	0.005	0.010	40,000	400	0.005	0.005	40,000	200	0.005	0.005
0.3	1.5	40,000	1,600	0.020	0.020	40,000	1,400	0.010	0.020	40,000	1,200	0.010	0.020
	2.0	40,000	1,500	0.010	0.020	40,000	1,300	0.010	0.020	40,000	1,100	0.010	0.010
	3.0	40,000	1,400	0.010	0.020	40,000	1,200	0.010	0.020	40,000	1,000	0.010	0.010
	4.0	30,000	1,200	0.010	0.010	30,000	1,000	0.010	0.010	30,000	700	0.005	0.010
	5.0	30,000	800	0.010	0.010	30,000	700	0.005	0.010	30,000	600	0.005	0.005
	6.0	30,000	600	0.005	0.010	30,000	500	0.005	0.005	30,000	400	0.005	0.005
0.5	2.5	40,000	2,800	0.040	0.050	40,000	2,800	0.030	0.040	40,000	2,200	0.020	0.030
	3.0	40,000	2,600	0.040	0.050	40,000	2,600	0.030	0.040	40,000	2,100	0.020	0.030
	4.0	40,000	2,400	0.030	0.050	40,000	2,400	0.020	0.030	40,000	2,000	0.020	0.020
	6.0	25,000	1,500	0.020	0.030	25,000	1,500	0.010	0.020	25,000	1,300	0.010	0.010
	8.0	16,000	1,200	0.020	0.020	16,000	1,100	0.010	0.020	16,000	850	0.010	0.010
0.75	4.0	32,000	2,400	0.030	0.030	32,000	2,200	0.020	0.030	32,000	2,000	0.020	0.020
1.0	5.5	40,000	4,000	0.050	0.050	40,000	4,000	0.030	0.030	40,000	3,000	0.020	0.030
	8.0	32,000	3,000	0.030	0.050	32,000	2,600	0.020	0.030	32,000	2,200	0.010	0.020

Radius Accuracy Inspection Test Results

Radius accuracy inspection report is attached as below with the ballnose type.

Measurement Data Sheet of Radius accuracy.

Lot No. SHMY × × × × ×
No. × ×

R tolerance 1.00 0.005
 -0.005

Angle	measurement	Error
0°	1.000	0.000
10°	1.001	0.001
		0.001



BNBC type

Copper Alloy



Endmills

I

Square

Radius

Ballnose

Multi-Purpose

General-Purpose

High Efficiency

Hardened Steel

Roughing

Non-Ferrous Metal

CFRP

Coated

Uncoated

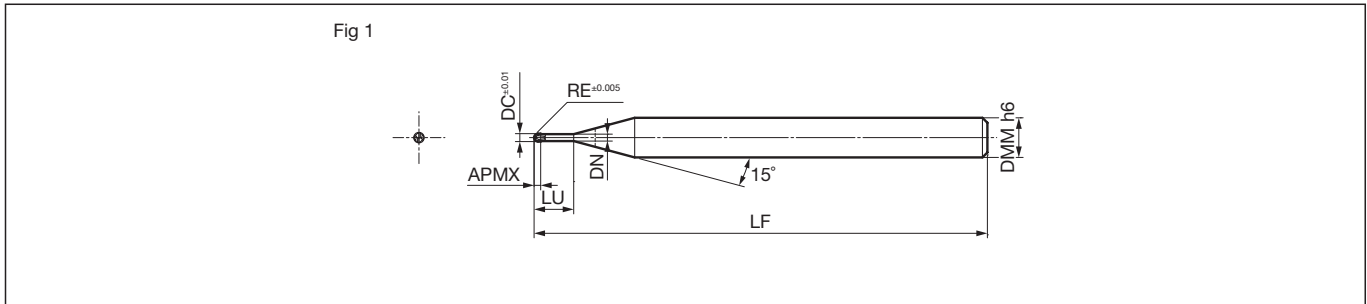

Body

Dimensions (mm)

Cat. No.	Stock	Ballnose Radius RE	Dia. DC	Cutting Edge Length APMX	Neck Length LU	Overall Length LF	Neck Dia. DN	Shank Dia. DMM	Fig
BNBC 2R010-0034	●	0.1	0.2	0.2	0.3	50	0.17	4	1
2R010-0104	●	0.1	0.2	0.2	1.0	50	0.17	4	1
2R020-0054	●	0.2	0.4	0.3	0.5	50	0.37	4	1
2R020-0204	●	0.2	0.4	0.3	2.0	50	0.37	4	1
2R030-0104	●	0.3	0.6	0.4	1.0	50	0.57	4	1
BNBC 2R030-0304	●	0.3	0.6	0.4	3.0	50	0.57	4	1
2R050-0304	●	0.5	1.0	0.6	3.0	50	0.97	4	1

Grade: BN700

Identification Code

BNBC 2 R030 - 010 4

Series Code No. of Flutes Ballnose Radius Neck Length Shank Dia.

Recommended Cutting Conditions

1. Use a machine with high rigidity for stable cutting.
2. Non-water soluble cutting oil is recommended. Supply as a mist or external coolant. Take fire prevention precautions to avoid fire hazards caused by sparks igniting during machining or tool breakage.
3. Shorten overhang as much as possible.
4. Adjust cutting conditions as necessary as machine rigidity and other conditions may vary.
5. Depths of cut shown in the table of conditions are maximum depths. Adjust the actual depth of cut to the desired machined surface roughness.

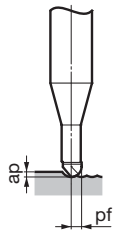

Side Milling

Work Material	Copper Alloy			
	Spindle Speed (min ⁻¹)	Feed Rate (mm/min)	Standard depth of cut (mm)	
Cat. No.			ap	pf
BNBC 2R010-0034	20,000	350	0.01	0.02
2R010-0104	-50,000	350	0.007	0.015
BNBC 2R020-0054	20,000	800	0.025	0.05
2R020-0204	-50,000	700	0.02	0.03
BNBC 2R030-0104	20,000	1,400	0.05	0.15
2R030-0304	-50,000	1,200	0.04	0.1
BNBC 2R050-0304	20,000	2,200	0.15	0.35
	-50,000			

MEMO

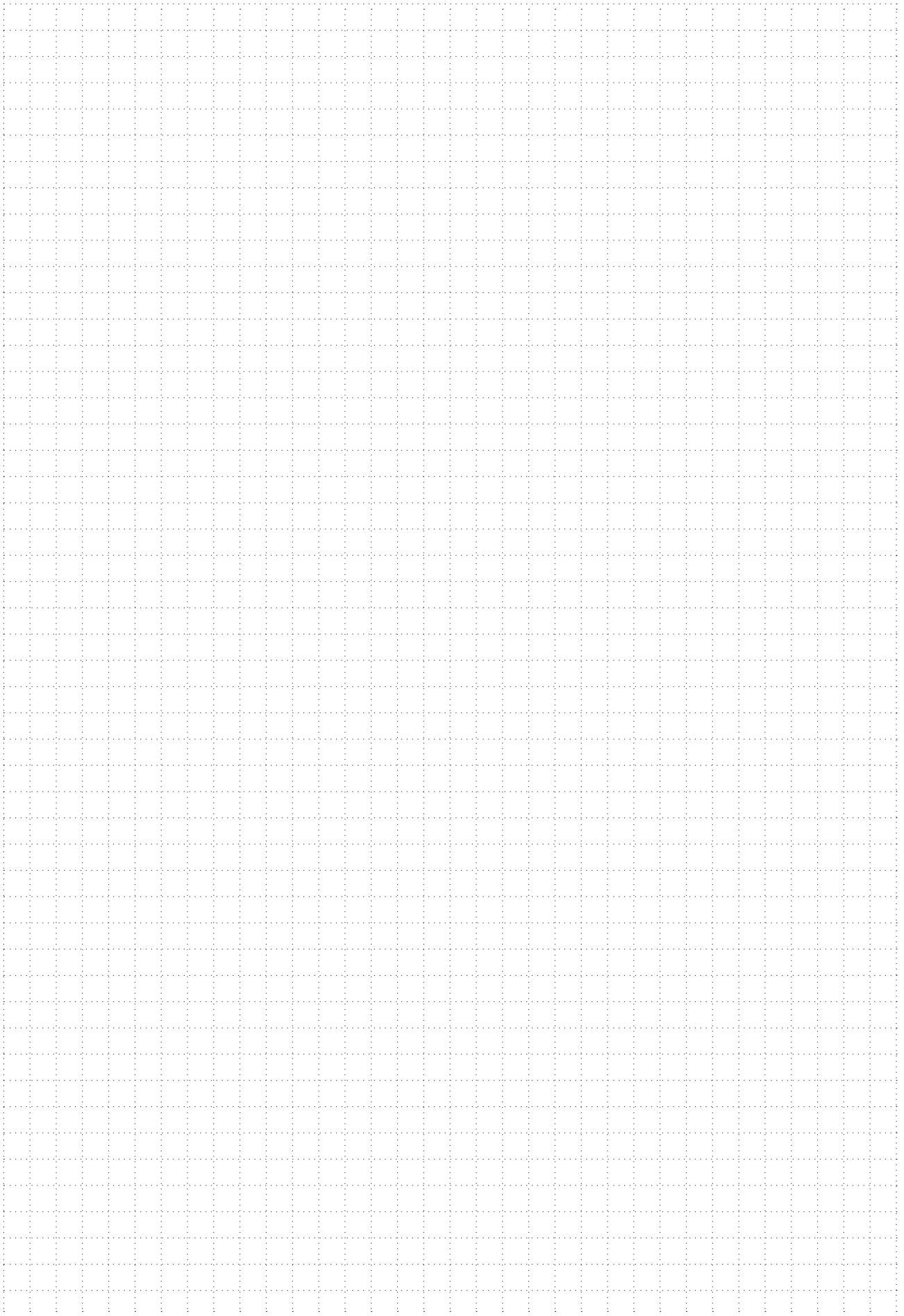

GSXSLT 30000C-1.5D type

- General Steel
- Carbon Steel
- Alloy Steel
- Pre-hardened Steel
- Tempered Steel / Die Steel
- Hardened Steel 45 to 55HRC
- Stainless Steel
- Ti Alloy Heat Resistant Alloy
- Cast Iron

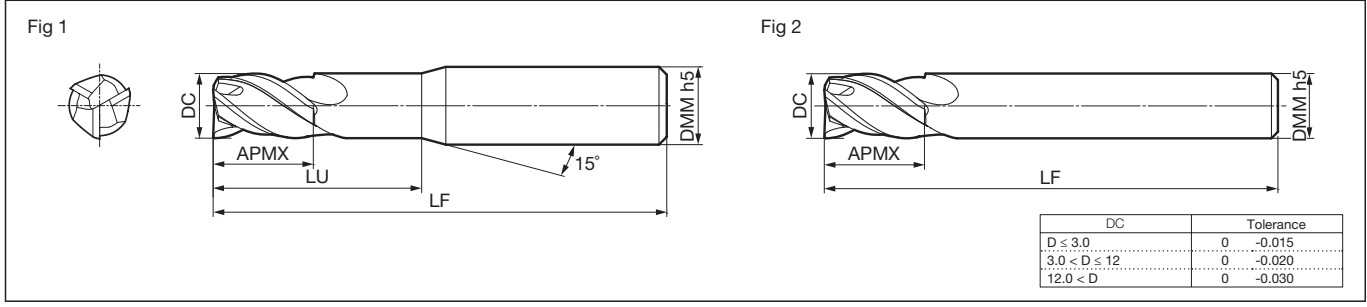

Body Dimensions (mm)

Cat. No.	Stock	Dia. DC	Cutting Edge Length APMX	Neck Length LU	Overall Length LF	Shank Dia. DMM	Fig
GSXSLT 30100C-1.5D	●	1.0	1.5	2.5	40	4	1
30150C-1.5D	●	1.5	2.3	3.3	40	4	1
30200C-1.5D	●	2.0	3.0	4.0	40	4	1
30250C-1.5D	●	2.5	3.8	4.8	40	4	1
30300C-1.5D	●	3.0	4.5	6.0	45	6	1
GSXSLT 30400C-1.5D	●	4.0	6.0	7.5	45	6	1
30500C-1.5D	●	5.0	7.5	9.5	50	6	1
30600C-1.5D	●	6.0	9.0	—	50	6	2
30700C-1.5D	●	7.0	11.0	13.0	60	8	1
30800C-1.5D	●	8.0	12.0	—	60	8	2
GSXSLT 30900C-1.5D	●	9.0	14.0	16.0	70	10	1
31000C-1.5D	●	10.0	15.0	—	70	10	2
31200C-1.5D	●	12.0	18.0	—	75	12	2

Grade: ACF20

Identification Code

GSXSLT 3 0100 C - 1.5D

Series Code No. of Flutes Dia. Corner Style C: Gash Land Cutting Edge Length

Endmills

Square

Radius

Ballnose

Multi-Purpose

General-Purpose

High Efficiency

Hardened Steel

Roughing

Non-Ferrous Metal

CFRP

Coated

Uncoated

GSXSLT 30000C-1.5D type

Recommended Cutting Conditions

1. For stable machining performance use rigid, high-precision machines and holders.
2. Use air blow when dry machining.
3. Use wet machining for stainless steel, heat-resistant alloy, and titanium alloy applications.
4. Use step machining of 0.1 DC when drilling stainless steel, heat-resistant alloy, and titanium alloy.
5. If the machine cannot achieve the recommended spindle speed, please use the maximum spindle speed available.

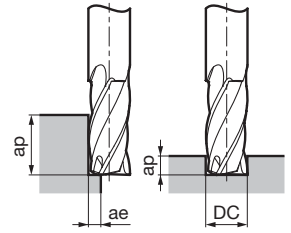

Side Milling

Work Material Cutting Conditions	Structural Steel SS		Carbon Steel SC (150 to 250HB)		Cast Iron FC		Alloy Steel SCM (25 to 35HRC)		Tempered Steel, Hardened Steel NAK, HPM (35 to 45HRC)		Hardened Steel (45 to 50HRC)		Stainless Steel SUS304,SUS316		Heat-Resistant Alloy Titanium Alloy	
	Spindle Speed (min ⁻¹)	Feed Rate (mm/min)	Spindle Speed (min ⁻¹)	Feed Rate (mm/min)	Spindle Speed (min ⁻¹)	Feed Rate (mm/min)	Spindle Speed (min ⁻¹)	Feed Rate (mm/min)	Spindle Speed (min ⁻¹)	Feed Rate (mm/min)	Spindle Speed (min ⁻¹)	Feed Rate (mm/min)	Spindle Speed (min ⁻¹)	Feed Rate (mm/min)	Spindle Speed (min ⁻¹)	Feed Rate (mm/min)
DC (mm)																
1.0	19,600	300	19,600	300	19,600	300	18,300	210	12,700	130	9,000	80	11,000	90	9,000	65
2.0	11,200	410	11,200	410	11,200	410	10,500	280	7,300	170	5,300	100	6,400	120	5,300	90
4.0	6,400	550	6,400	550	6,400	550	6,000	370	4,200	230	3,000	140	3,600	150	3,000	120
6.0	4,600	670	4,600	670	4,600	670	4,300	460	3,000	270	2,200	170	2,700	180	2,200	130
8.0	3,400	670	3,400	670	3,400	670	3,200	460	2,200	270	1,600	170	2,000	180	1,600	130
10.0	2,800	670	2,800	670	2,800	670	2,600	460	1,800	270	1,300	170	1,600	180	1,300	130
12.0	2,300	670	2,300	670	2,300	670	2,200	460	1,500	270	1,100	170	1,300	180	1,100	130
Standard Depth of Cut	ap	1.5DC										1.0DC				
	ae	0.05DC										0.02DC				

Groove Milling

Work Material Cutting Conditions	Structural Steel SS		Carbon Steel SC (150 to 250HB)		Cast Iron FC		Alloy Steel SCM (25 to 35HRC)		Tempered Steel, Hardened Steel NAK, HPM (35 to 45HRC)		Hardened Steel (45 to 50HRC)		Stainless Steel SUS304,SUS316		Heat-Resistant Alloy Titanium Alloy	
	Spindle Speed (min ⁻¹)	Feed Rate (mm/min)	Spindle Speed (min ⁻¹)	Feed Rate (mm/min)	Spindle Speed (min ⁻¹)	Feed Rate (mm/min)	Spindle Speed (min ⁻¹)	Feed Rate (mm/min)	Spindle Speed (min ⁻¹)	Feed Rate (mm/min)	Spindle Speed (min ⁻¹)	Feed Rate (mm/min)	Spindle Speed (min ⁻¹)	Feed Rate (mm/min)	Spindle Speed (min ⁻¹)	Feed Rate (mm/min)
DC (mm)																
1.0	19,600	240	19,600	300	19,600	300	18,300	210	12,700	130	9,000	80	11,000	65	4,500	25
2.0	11,200	320	11,200	410	11,200	410	10,500	280	7,300	170	5,300	100	6,400	85	2,650	35
4.0	6,400	450	6,400	550	6,400	550	6,000	370	4,200	230	3,000	140	3,600	100	1,500	50
6.0	4,600	540	4,600	670	4,600	670	4,300	460	3,000	270	2,200	170	2,650	130	1,150	55
8.0	3,400	540	3,400	670	3,400	670	3,200	460	2,200	270	1,600	170	2,000	130	800	55
10.0	2,800	540	2,800	670	2,800	670	2,600	460	1,800	270	1,300	170	1,600	130	650	55
12.0	2,300	540	2,300	670	2,300	670	2,200	460	1,500	270	1,100	170	1,300	130	500	55
Standard Depth of Cut	ap	0.2DC		0.5DC				0.2DC		0.05DC		0.2DC				

Drilling

Work Material Cutting Conditions	Structural Steel SS		Carbon Steel SC (150 to 250HB)		Cast Iron FC		Alloy Steel SCM (25 to 35HRC)		Tempered Steel, Hardened Steel NAK, HPM (35 to 45HRC)		Hardened Steel (45 to 50HRC)		Stainless Steel SUS304,SUS316		Heat-Resistant Alloy Titanium Alloy	
	Spindle Speed (min ⁻¹)	Feed Rate (mm/min)	Spindle Speed (min ⁻¹)	Feed Rate (mm/min)	Spindle Speed (min ⁻¹)	Feed Rate (mm/min)	Spindle Speed (min ⁻¹)	Feed Rate (mm/min)	Spindle Speed (min ⁻¹)	Feed Rate (mm/min)	Spindle Speed (min ⁻¹)	Feed Rate (mm/min)	Spindle Speed (min ⁻¹)	Feed Rate (mm/min)	Spindle Speed (min ⁻¹)	Feed Rate (mm/min)
DC (mm)																
1.0	19,600	70	19,600	90	19,600	90	18,300	60	12,700	40	9,000	25	11,000	20	4,500	10
2.0	11,200	90	11,200	120	11,200	120	10,500	80	7,300	50	5,300	30	6,400	25	2,650	15
4.0	6,400	130	6,400	160	6,400	160	6,000	110	4,200	70	3,000	40	3,600	30	1,500	20
6.0	4,600	160	4,600	200	4,600	200	4,300	130	3,000	80	2,200	50	2,650	40	1,150	20
8.0	3,400	160	3,400	200	3,400	200	3,200	130	2,200	80	1,600	50	2,000	40	800	20
10.0	2,800	160	2,800	200	2,800	200	2,600	130	1,800	80	1,300	50	1,600	40	650	20
12.0	2,300	160	2,300	200	2,300	200	2,200	130	1,500	80	1,100	50	1,300	40	500	20

Endmills

1

Square

Radius

Ballnose

Multi-Purpose

General-Purpose

High Efficiency

Hardened Steel

Roughing

Non-Ferrous Metal

CFRP

Coated

Uncoated

SSUP 3000ZX type

- General Steel
- Carbon Steel
- Alloy Steel
- Pre-hardened Steel
- Tempered Steel / Die Steel
- Hardened Steel 45 to 55HRC
- Hardened Steel 55 to 60HRC
- Stainless Steel
- Ti Alloy Heat Resistant Alloy
- Cast Iron

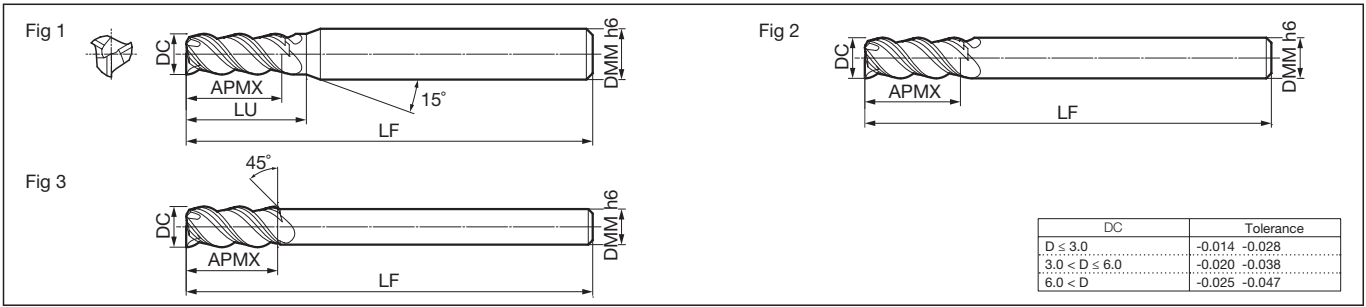

Body

Dimensions (mm)

Cat. No.	Stock	Dia. DC	Cutting Edge Length APMX	Neck Length LU	Overall Length LF	Shank Dia. DMM	Fig
SSUP 3020ZX	●	2.0	6.0	7.0	50	4	1
3025ZX	●	2.5	8.0	9.0	50	4	1
3030ZX	●	3.0	8.0	9.5	50	6	1
3035ZX	●	3.5	10.0	11.5	50	6	1
3040ZX	●	4.0	11.0	12.5	50	6	1
SSUP 3045ZX	●	4.5	11.0	12.5	50	6	1
3050ZX	●	5.0	13.0	14.5	60	6	1
3055ZX	●	5.5	13.0	14.5	60	6	1
3060ZX	●	6.0	13.0	—	60	6	2
3065ZX	●	6.5	16.0	18.0	70	8	1
SSUP 3070ZX	●	7.0	16.0	18.0	70	8	1
3075ZX	●	7.5	16.0	18.0	70	8	1
3080ZX	●	8.0	19.0	—	80	8	2
3085ZX	●	8.5	19.0	21.5	90	10	1
3090ZX	●	9.0	19.0	21.5	90	10	1
SSUP 3095ZX	●	9.5	19.0	21.5	90	10	1
3100ZX	●	10.0	22.0	—	90	10	2
3110ZX	●	11.0	22.0	24.5	90	12	1
3120ZX	●	12.0	26.0	—	90	12	2
3130ZX	●	13.0	26.0	—	100	12	3
SSUP 3140ZX	●	14.0	26.0	28.5	110	16	1
3150ZX	●	15.0	26.0	28.5	110	16	1
3160ZX	●	16.0	32.0	—	115	16	2

Grade: ACZ50M

Endmills

I

Square

Radius

Ballnose

Multi-Purpose

General-Purpose

High Efficiency

Hardened Steel

Roughing

Non-Ferrous Metal

CFRP

Coated

Uncoated

SSUP 3000ZX type

Recommended Cutting Conditions

1. If the machine cannot achieve the recommended spindle speed, please use the maximum spindle speed available.
2. If cutting noise and vibration occur, please reduce the cutting conditions accordingly.

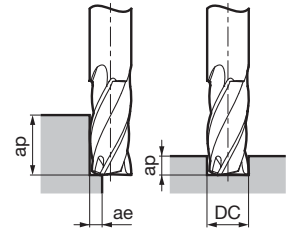

Side Milling and Groove Milling

Work Material Cutting Conditions	Carbon Steel, Cast Iron (150 to 250HB)		Alloy Steel SCM (25 to 35HRC)		Tempered Steel / Hardened Steel NAK, HPM (40 to 50HRC)		Stainless Steel (*)		Heat-Resistant Alloy Titanium Alloy (20 to 45HRC)		
	DC (mm)	Spindle Speed (min ⁻¹)	Feed Rate (mm/min)	Spindle Speed (min ⁻¹)	Feed Rate (mm/min)	Spindle Speed (min ⁻¹)	Feed Rate (mm/min)	Spindle Speed (min ⁻¹)	Feed Rate (mm/min)	Spindle Speed (min ⁻¹)	Feed Rate (mm/min)
2.0	9,000	540	6,000	320	4,000	240	5,500	240	2,600	90	
4.0	6,600	600	4,500	340	3,000	280	4,000	240	2,000	90	
6.0	4,800	720	3,000	360	2,500	280	3,000	360	1,200	90	
8.0	3,600	750	2,200	460	2,000	300	2,000	390	1,000	100	
10.0	2,800	750	1,800	460	1,500	300	1,700	410	800	120	
12.0	2,400	710	1,500	410	1,200	280	1,500	380	700	100	
14.0	2,200	660	1,300	370	1,000	270	1,200	320	600	95	
16.0	1,800	490	1,100	320	800	230	1,000	270	500	90	
Side Milling	ap	1.5DC									
	ae	0.1DC				0.05DC		0.1DC		0.05DC	
Groove Milling	ap	1.0DC				0.2DC		0.3DC		0.2DC	

1. For groove milling of stainless steel, use 60% of the recommended spindle speed and 40% of the recommended feed rate. (*)
2. If cutting noise and vibration occur, please reduce the cutting conditions accordingly.

Drilling

Work Material Cutting Conditions	Carbon Steel, Cast Iron (150 to 250HB)		Alloy Steel SCM (25 to 35HRC)		Tempered Steel / Hardened Steel NAK, HPM (40 to 50HRC)		Stainless Steel		Heat-Resistant Alloy Titanium Alloy (20 to 45HRC)	
	DC (mm)	Spindle Speed (min ⁻¹)	Feed Rate (mm/min)	Spindle Speed (min ⁻¹)	Feed Rate (mm/min)	Spindle Speed (min ⁻¹)	Feed Rate (mm/min)	Spindle Speed (min ⁻¹)	Feed Rate (mm/min)	Spindle Speed (min ⁻¹)
2.0	9,000	150	6,000	100	4,000	60	6,400	25	2,600	20
4.0	6,600	250	4,500	170	3,000	80	3,600	30	2,000	40
6.0	4,800	300	3,000	200	2,500	110	2,650	40	1,200	40
8.0	3,600	300	2,200	200	2,000	120	2,000	40	1,000	50
10.0	2,800	300	1,800	200	1,500	120	1,600	40	800	50
12.0	2,400	300	1,500	200	1,200	120	1,300	40	700	50
14.0	2,200	250	1,300	150	1,000	80	1,150	35	600	40
16.0	1,800	200	1,100	120	800	60	1,000	35	500	30

1. If cutting noise and vibration occur, please reduce the cutting conditions accordingly.
2. Supply water-soluble coolant when machining stainless steel, heat-resistant alloy and titanium alloy. Use dry machining (air blow) for all other work materials.

Endmills

I

Square

Radius

Ballnose

Multi-Purpose

General-Purpose

High Efficiency

Hardened Steel

Roughing

Non-Ferrous Metal

CFRP

Coated

Uncoated

